



OVER 35 YEARS OF INNOVATION, QUALITY, SAFETY.
IMPORTANT OWNER-OPERATOR INSTALLATION INSTRUCTIONS

D2124



Warnings

Truck Bed and Camper Protection

Torklift **does not** recommend installing your camper on top of a plastic bed liner (or other compressible material such as foam). These materials can act as a spring, causing increased vertical truck camper movement independent of the vehicle. Plastic bed liners can slide on the truck bed surface, and the truck camper can slide on top of the bed liner. Using a plastic bed liner or similar compressible material will void your warranty and may additionally cause truck bed and/or camper damage.











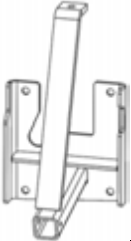

Minor movement or settling can occur in some incidental harsh driving conditions (on or off-road). A rubber bed mat is recommended to protect the truck bed and camper, but is not a requirement to maintain the Torklift legendary lifetime warranty.

Suspension

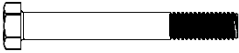
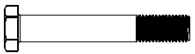
To significantly reduce body roll, sag and sway Torklift strongly recommends the StableLoad. Torklift International StableLoads improve safety, handling, and to help level your truck.

If your truck is additionally equipped with suspension air bags Torklift cautions against over pressurization as this may lead to unsafe vehicle handling characteristics. We have found that airbags used in conjunction with StableLoads have allowed operators to lower air bag pressure by 50% or more. Only pressurize suspension air bags enough to level the truck.

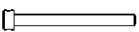
Parts Inventory

Item Image	Item Description	Quantity
	<p style="text-align: center;"><u>Tie Down Receivers</u> (Driver side pictured)</p>	2
	Bent Tie Down Inserts	2
	Driver Front Clamp Strap	1
	Passenger Front Clamp Strap	1
	Driver Rear Clamp Straps	1
	Passenger Rear Clamp Strap	1
	1/2"-13 x 4" Grade 8 Hex Bolt	7
	1/2"-13 x 3.5" Grade 8 Hex Bolt	1
	1/2"-13 Grade 8 Hex Nut	7
	1/2" Grade 8 Lock Washer	8
	1/2" SAE Washer	8
	Insert Pin	2
	3/4"OD x 2.6875" Spacer Pipe	4

Step 1:

Begin on the drive side of the vehicle and remove the forward most bed mount bolt as shown below in photo 1.1 below.

Note: The bolt is secured with blue thread locking compound and is tightened to a very high torque value.

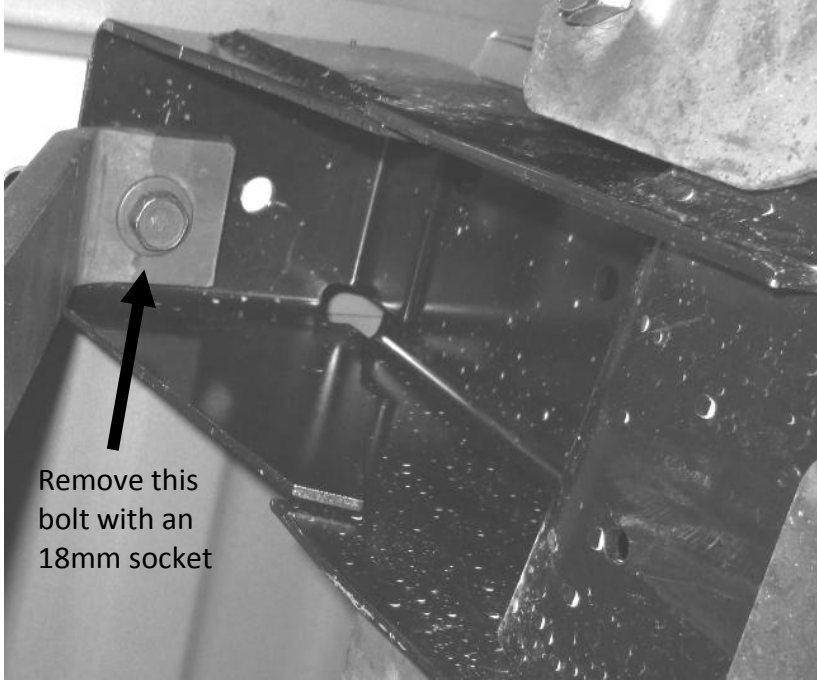

Step 2:

Lift the driver side **tie down receiver** up into place so that the hole in the bent strap aligns with the hole in the vehicle bed mount. Secure the tie down in place by re-installing the bolt removed in step one and leaving finger tight at this time. Reference figure 2.1 on the following page.

Figure 2.1

Driver Side

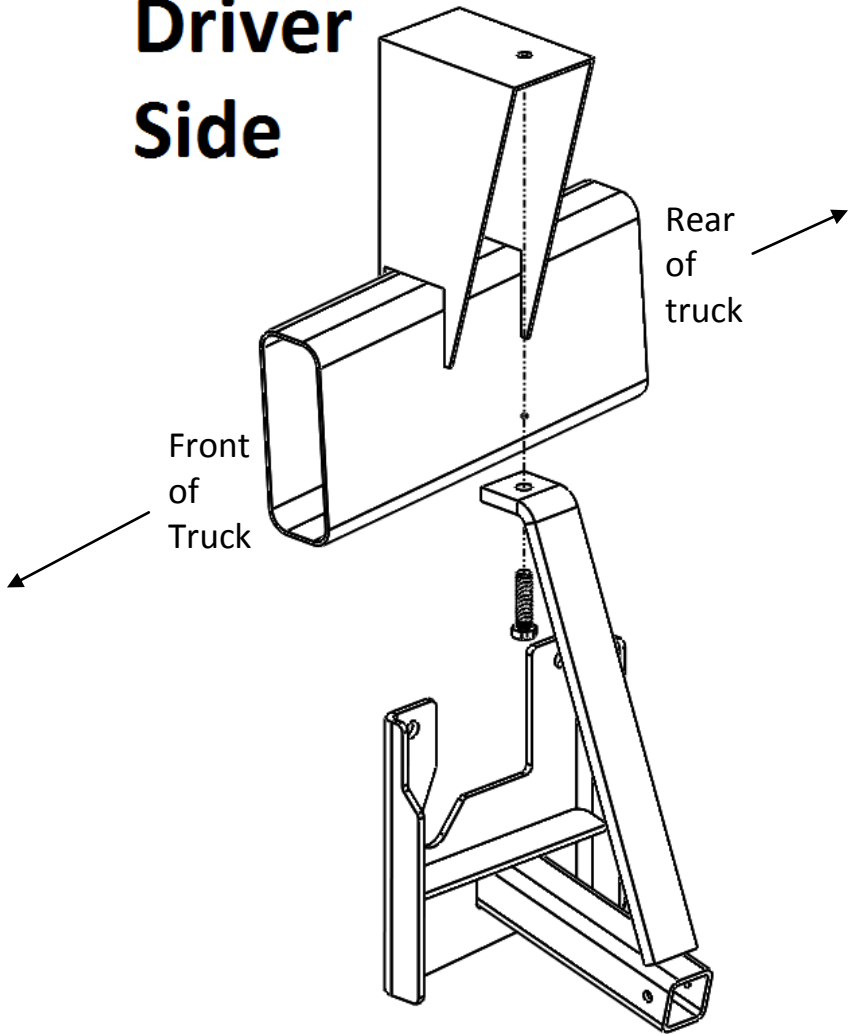

Step 3:

Install the **Driver Front Clamp Strap** on the inside of the frame rail from the top of the frame down. The welded-on nut will be on the top of the frame facing towards the **Tie Down Receiver**. Install the **1/2"-13 x 3.5" Hex Bolt** with one **1/2" Lock Washer** and one **1/2" SAE Washer** through the front of the **tie down receiver** and thread it into the welded on nut of the **Driver Front Clamp Strap**. Reference figure 3.1 and photo 3.2 on the following page.

Figure 3.1

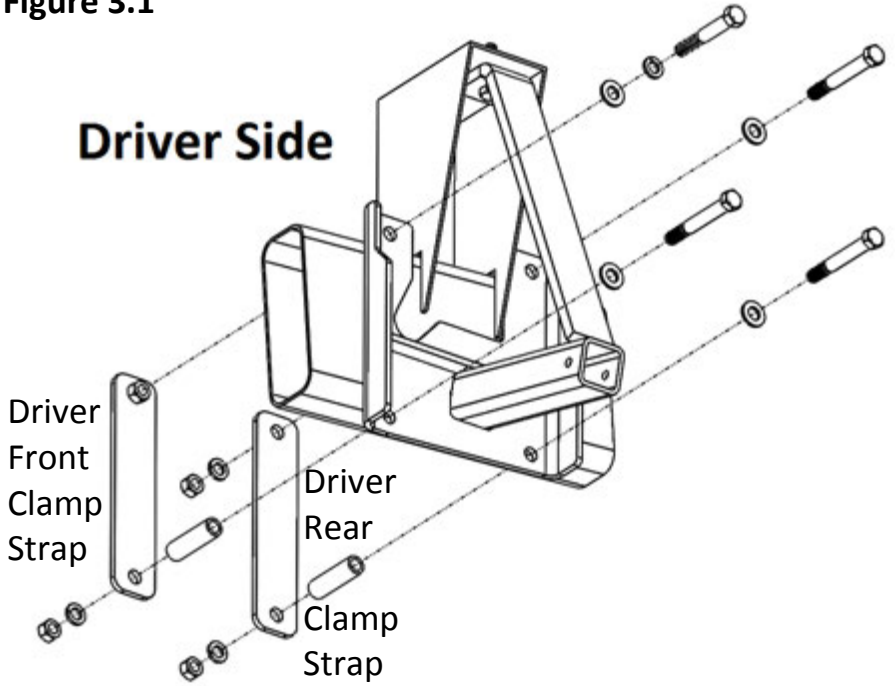

Photo 3.2



Step 4:

Install the **Driver Rear Clamp Strap** on the inside of the frame rail from the bottom of the frame up. Install one **1/2"-13 x 4" Hex Bolt** with one **1/2" SAE Washer** through the front of the **tie down receiver** and out through upper hole in the **Rear Clamp Strap**. Secure with one **1/2" Lock Washer** and one **1/2" Hex Nut**. Reference figure 3.1 and leave hardware hand tight at this time.

Step 5:

Install one **1/2"-13 x 4" Hex Bolt** with one **1/2" SAE Washer** through each of the remaining two holes on the bottom of the **tie down receiver**. Install a spacer pipe onto each bolt between the **tie down receiver** and **clamp straps**. Secure with one **1/2" Lock Washer** and one **1/2" Hex Nut**. Reference figure 3.1 and leave hardware hand tight at this time.

Step 6:

Begin to tighten each of the four hex bolts in turn, until both the front and rear clamp straps are seated flush to the inside of the vehicle frame. Next, re-tighten the bed mount bolt and torque to **80 ft-lbs**. At this time, torque the two upper hex bolts without the tubing spacers to **15 ft-lbs**. Next, torque the lower two hex bolts with the tubing spacers to **55 ft-lbs**.

The driver side tie down installation is complete.

Step 7:

Repeat steps 1 and 2 for the passenger side of the vehicle. Install the **Passenger Front Clamp Strap** on the inside of the frame rail from the bottom of the frame up. The jog in the strap will face the front of the truck to avoid the exhaust hanger stud as shown below. Secure the clamp strap by installing one **1/2"-13 x 4" Hex Bolt** with one **1/2" SAE Washer** through the front of the **tie down receiver** and out through upper hole in the **Passenger Front Clamp Strap**. Secure with one **1/2" Lock Washer** and one **1/2" Hex Nut**. Reference Photo 7.1 and leave hardware hand tight at this time.

Photo 7.1



Step 8:

Install the **Passenger Rear Clamp Strap** making sure the notch is facing the top of the frame and the front of the truck. Repeat steps 4 through 6 to complete the passenger side tie down installation.

Note: A small plastic plug (pictured in photo 7.1) may need to be removed to install the rear clamp strap on the passenger side.

Step 9:

Install the labeled bent tie down inserts into each receiver. Secure with insert pin.