

TORKLIFT **INTERNATIONAL**

OVER 35 YEARS OF INNOVATION, QUALITY, SAFETY.
IMPORTANT OWNER-OPERATOR INSTALLATION INSTRUCTIONS

D2132

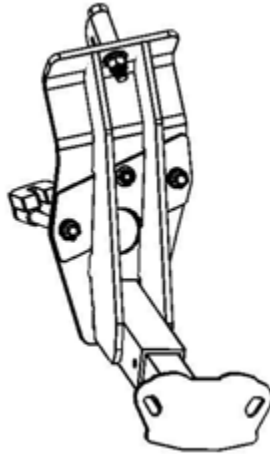

Warnings

Truck Bed and Camper Protection

Torklift **does not** recommend installing your camper on top of a plastic bed liner (or other compressible material such as foam). These materials can act as a spring, causing increased vertical truck camper movement independent of the vehicle. Plastic bed liners can slide on the truck bed surface, and the truck camper can slide on top of the bed liner. Using a plastic bed liner or similar compressible material will void your warranty and may additionally cause truck bed and/or camper damage.











Minor movement or settling can occur in some incidental harsh driving conditions (on or off-road). A rubber bed mat is recommended to protect the truck bed and camper, but is not a requirement to maintain the Torklift legendary lifetime warranty.

Suspension

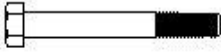

To significantly reduce body roll, sag and sway Torklift strongly recommends the StableLoad. Torklift International StableLoads improve safety, handling, and to help level your truck.

If your truck is additionally equipped with suspension air bags Torklift cautions against over pressurization as this may lead to unsafe vehicle handling characteristics. We have found that airbags used in conjunction with StableLoads have allowed operators to lower air bag pressure by 50% or more. Only pressurize suspension air bags enough to level the truck.

Parts Inventory

Item Image	Item Description	Quantity
	<u>Tie Down Receiver</u>	2
	Bent Steel Tie Down Insert	2
	Clamp Plate	2
	Top Mount Hook Bracket	2
	Side Mount Hook Bracket	2
	1/2"-13 x 8-1/2" GR8 Hex Bolt	2
	1/2"-13 x 2" GR8 Hex Bolt	2
	1/2"-13 GR8 Hex Nut	6
	1/2" SAE Flat Washer	8
	1/2"-13 x 3-1/2" GR8 Bolt	2
	1/2" Lock Washer	6
	3/8"-16 x 1-1/2" SS Bolt	2

Parts Inventory

Item Image	Item Description	Quantity
	3/8" Flat Washer	4
	3/8"-16 Thin Nylock Nut GR8	2
	Snapper Pin	2

Installation Notes:

Step 1

Starting with the driver side of the vehicle, locate the front leaf spring perch on the side of the frame, just behind the rear most cab mount. This will be the mounting location for the **Tie Down Receiver**. See Figure 1.1



Figure 1.1

Step 2

Insert a **1/2"-13 x 3-1/2" Hex Bolt GR8** into a **Top Mount Hook Bracket**. Hook the top of **Top Mount Hook Bracket** over the top of the spring hanger bracket. (See figure 2.1) Place the **Tie Down Receiver** over the top of the spring perch mount, with the large hole sitting over the head of the main spring bolt. Secure the **1/2"-13 x 3-1/2" Hex Bolt GR8** with one **1/2" SAE Washer GR8**, one **1/2" Lock Washer** and one **1/2"-13 Hex Nut GR8** shown in Figure 2.2 below. Hand Tighten.



Figure 2.1

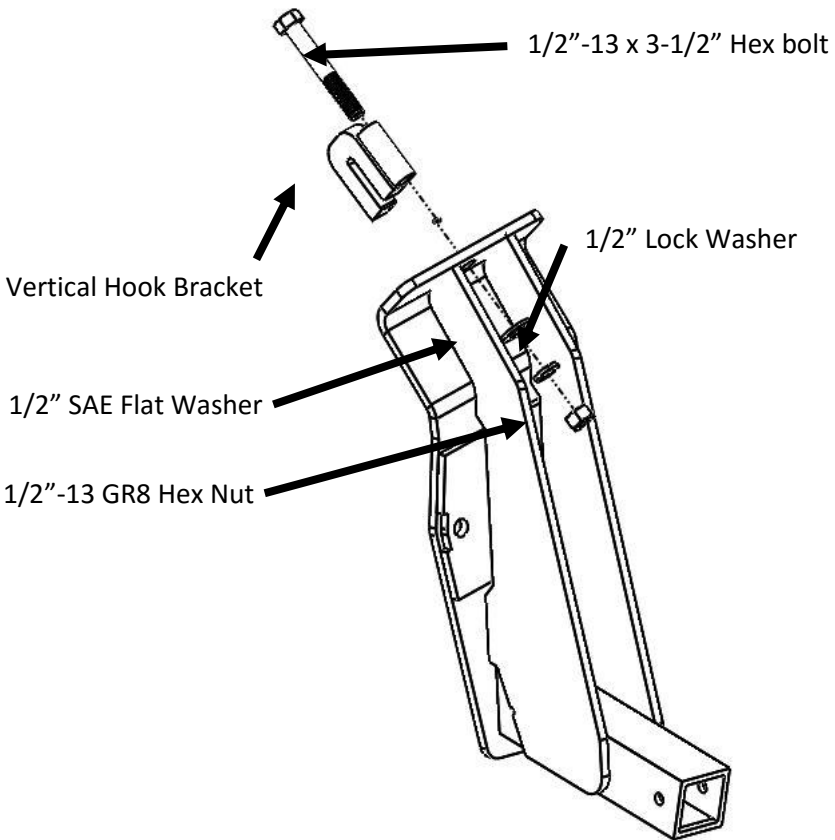

Figure 2.2

Step 3

From inside the spring perch, Insert the **3/8"-16 x 1-1/2" SS Bolt** and **3/8" Flat Washer** through the small hole in the **Clamp Strap** and out through the small hole just above the leaf spring bolt as shown in Figure 3.1. Use one **3/8" Flat Washer** and one **3/8"-16 Thin Nylock Nut GR8** on the outside of the **Tie Down Receiver** to secure the **Clamp Plate**.

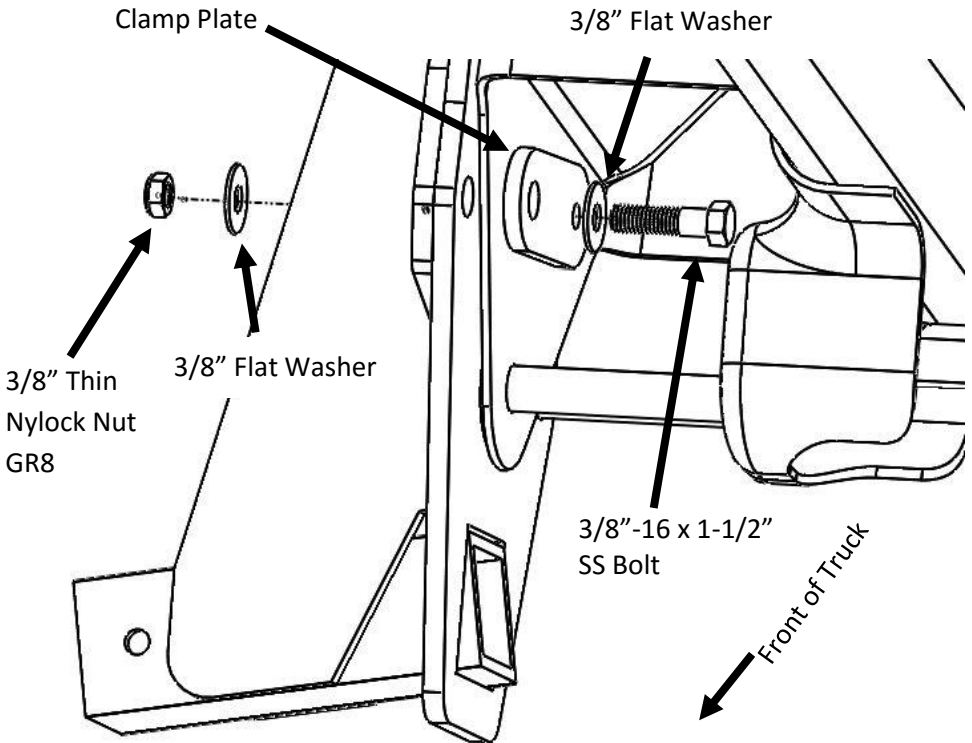

Figure 3.1 (Leaf spring not shown for clarity. Driver side shown)

Step 4

Insert the **1/2"-13 x 2" GR8 Hex Bolt** with one **1/2" SAE Flat Washer** through the **Clamp Plate** and tie down receiver hole as shown in Figure 4.1. Secure the bolt with one **1/2" SAE Flat Washer**, one **1/2" Lock Washer** and one **1/2"-13 GR8 Hex Nut**.

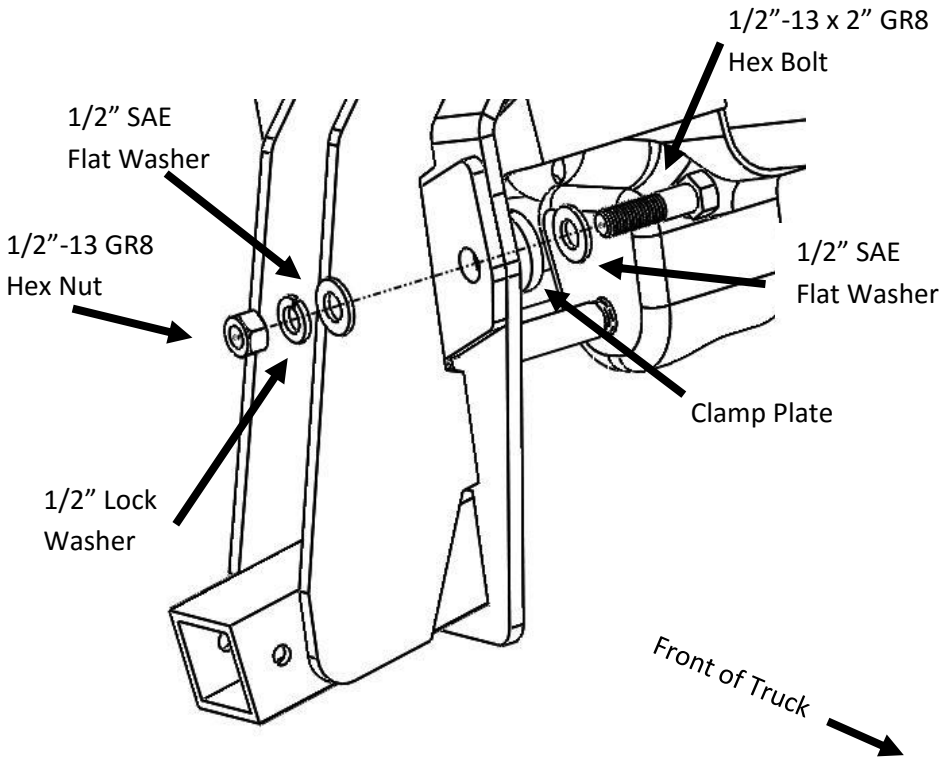

Figure 4.1 (Leaf spring not shown for clarity. Driver side shown)

Step 5

With all hardware loose, install one **1/2"-13 x 8-1/2" GR8 Hex Bolt** through a **Side Mount Hook Bracket**. Hook the bracket onto the front side of the spring perch as shown in Figure 5.1. Secure the **Tie Down Receiver** to the **1/2"-13 x 8-1/2" GR8 Hex Bolt** with one **1/2" SAE Washers GR8**, one **1/2" Lock Washer** and one **1/2"-13 Hex Nut GR8**. Make sure the **Side Mount Hook Bracket** is pushed up as far as possible on the leaf spring hanger.

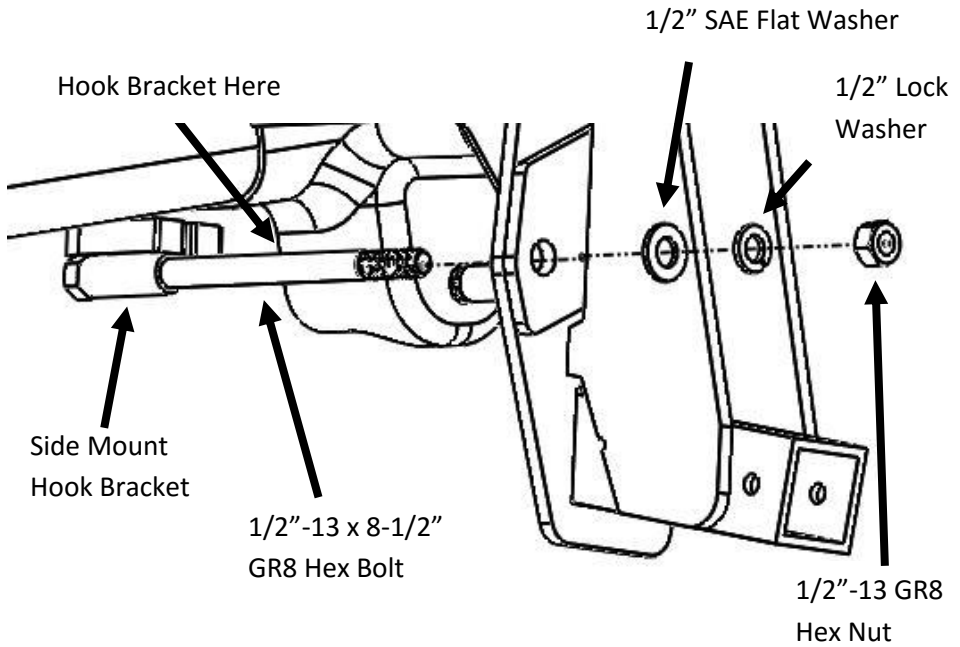

Figure 5.1 (Driver side shown)

Repeat steps 1 through 5 on the passenger side of the truck.

Step 6

Tighten all hardware evenly, beginning with the **Top Mount Hook Bracket**. The 3/8" hardware should be torqued to 30 lb-ft, and the 1/2" hardware should be torqued to 55 lb-ft.

TIEDOWN INSERT INSTALLATION INSTRUCTIONS

On one end of each of your tie down inserts is a triangular plate referred to by Torklift as a bullet plate. In most cases, the tie down inserts should be installed with the shorter side of the bullet plate facing away from each other (The shorter side of the front insert should point to the front of the truck and the shorter side of the rear insert should point towards the rear of the truck).



DRIVERS SIDE FRONT

DRIVERS SIDE REAR

Once installed, attach the TorkLift directional stickers to the face of the bullet plate on the insert as a reminder.

IMPORTANT NOTE: *Your tie down inserts are designed to have clearance inside of the receiver. This is to account for road debris, as well as aid in installation and removal. Some rattle may be expected if the inserts are left installed while not under load from the camper.*