



REAR BUMPER

Part No. JL013T



Fits: Current JEEP GLADIATOR



REMOVE CONTENTS FROM BOX. VERIFY ALL PARTS ARE PRESENT.



READ INSTRUCTIONS CAREFULLY BEFORE STARTING INSTALLATION.

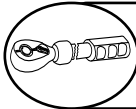

DO NOT OVER TORQUE. STANDARD OPERATING LOAD FOR TIGHTENING BODY MOUNT NUTS & BOLTS VARIES FROM 35-40 FOOT POUND FOR M10 AND 60 TO 70 FOOT POUND FOR M12



60-180 min



Cutting Not Required



Drilling Is Optional

PARTS LIST:

Qty	Part Description	Qty	Part Description
1	TrailFX Rear Bumper	6	12-1.75mm x 40mm Hex Bolts
1	Driver/Left Support Bracket	16	12mm x 32mm OD x 3mm Flat Washers
1	Passenger/Right Support Bracket	10	12mm Lock Washers
2	Tow Hooks	10	12mm Hex Nuts
4	Sensor Plugs	4	12mm Plastic Retainers
4	Retaining Clips	4	10mm x 30mm Hex Bolts
4	Foam Spacers	4	10mm x 30mm OD x 2.5mm Flat Washers
4	Foam Washers	4	10mm Lock Washers
1	Sensor Cover Kit	2	10mm Nut Plates
2	License Plate Plugs	8	4mm x 10mm Button Head Bolts
2	12-1.75mm x 45mm Double Bolt Plates	1	2.5mm Hex Wrench

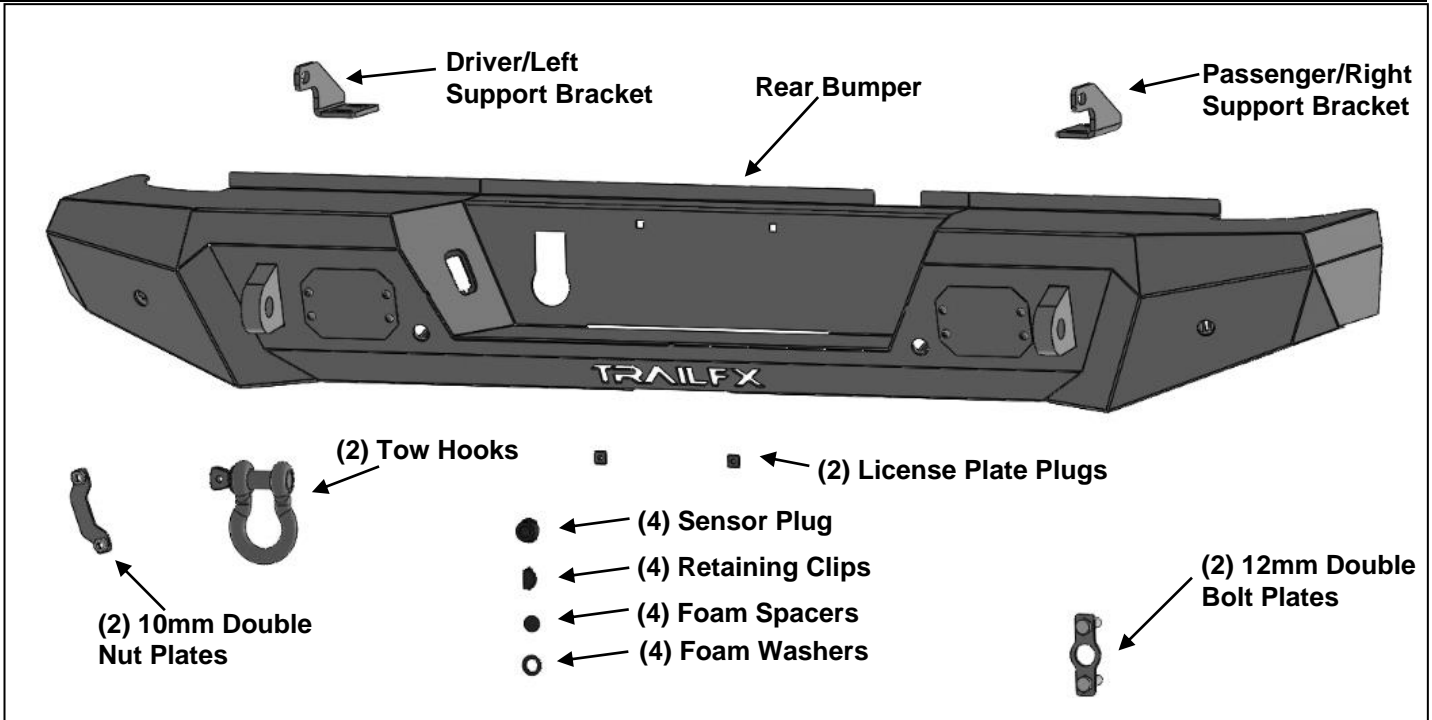

PROCEDURE:

REMOVE CONTENTS FROM BOX. VERIFY ALL PARTS ARE PRESENT. READ INSTRUCTIONS CAREFULLY BEFORE STARTING INSTALLATION. BUMPER IS HEAVY, ASSISTANCE IS RECOMMENDED TO AVOID POSSIBLE INJURY OR DAMAGE TO THE VEHICLE.

1. Start installation from under the rear bumper. Unplug the trailer plug, sensors and wiring harnesses leading to the rear bumper, **(Figures 1 & 2)**.
2. Remove the (2) lower factory bolts attaching the bumper to the receiver hitch, **(Figure 3)**.
3. Remove the rear license plate to reveal (2) factory bolts. Remove the (2) bolts, **(Figure 4)**.
4. **Determine if vehicle is equipped with rear bed guards**
For vehicles not equipped with bed guards:
 - a. Skip to **Step 5**.**For vehicles equipped with bed guards**
 - a. Move to the Driver/Left side of the vehicle. Remove the lower factory bolt that attaches the bed guard to the receiver hitch, **(Figure 5)**.
 - b. Remove the (2) upper factory bolts that attaches the bed guard to the frame, **(Figure 6)**.
 - c. Remove the (2) factory bolts that attaches the bed guard to the rear bumper, **(Figure 7)**.
NOTE: Keep the (2) factory nuts attaching the bumper to the hitch.
 - d. Repeat previous **Steps** to remove the Passenger/Right bed guard.
5. Place blocks or jack stands under the bumper to support it during mounting nut removal. Once the bumper has been safely supported, remove the factory hardware attaching the bumper brackets to the receiver hitch. **(Figure 7)**. **IMPORTANT:** Assistance is highly recommended to hold bumper in position during hardware removal.
6. Slide the bumper over the tow hooks and place on a smooth, clean surface, **(Figure 8)**.
7. Remove the tow hooks, (if equipped). Tow hooks cannot be reattached after Bumper is installed.
8. Depending on tow package, it may be necessary or easier to install sensors at this time, (if equipped)
Models without bumper sensors:
 - a. Select (4) Rubber Plugs.
 - b. From behind bumper, push plugs into sensor mounting holes, **(Figure 9)**.**Models with bumper mounted back-up sensors:**
 - a. Remove sensors and wiring harness from the back of the factory bumper.
 - b. Select (1) sensor. Insert (1) 15.5mm Foam Washer, (1) factory sensor, (1) Foam Spacer and (1) Retaining Clip into the mounting sleeve in the back of the bumper, **(Figure 10)**.
 - c. **(OPTIONAL)** Secure sensor to the sleeve with (2) 4mm x 10mm Button Head Screws, **(Figure 10)**. **IMPORTANT:** Sensors fit snug in sleeves. The 4mm Bolts are used to apply slight pressure to lock the sensors in place. Tighten both screws evenly until they touch the sensor body only. Do not overtighten screws or damage to sensors will result.
 - d. Repeat previous **Steps** to install the remaining (3) sensors.
9. **Determine if Lights will be attached, (lights not included)**
 - a. Select (1) light. Remove the cover panel attached to the Bumper, **(Figure 11)**.
 - b. Attach light to the Driver/Left location on the back of the Bumper.
 - c. Follow manufacturer's instructions to properly wire the light to the vehicle electrical system.
 - d. Repeat previous **Steps** to attach (1) light to the Passenger/Right side.
10. Select the Driver/Left Support Bracket. Attach the Bracket to the top of the receiver hitch with (2) 12mm Hex Bolts, (4) 12mm Flat Washers, (2) 12mm Lock Washers and (2) 12mm Hex Nuts, **(Figures 12 & 13)**. Do not tighten hardware. Repeat this **Step** to attach the Passenger/Right Support Bracket to the hitch.
11. Select (1) 12mm Double Bolt Plate. Insert the Bolt Plate into the Driver/Left side of the Bumper. Thread (2) 12mm Plastic Retainers onto the Bolt Plate to hold it in place, **(Figure 14)**. Repeat this **Step** to insert (1) 12mm Bolt Plate into the Passenger/Right side of the Bumper.
12. With assistance, hold the Bumper up to the hitch and Support Brackets. Temporarily support the weight of the Bumper. **WARNING:** To avoid possible injury or damage to the vehicle, do not proceed until the bumper is fully and safely supported.
13. Attach the Bumper to the hitch with (4) 12mm Flat Washers, (4) 12mm Lock Washers and (4) 12mm Hex Nuts, **(Figure 15)**. Do not tighten hardware.
14. Attach the Bumper to the Support Brackets with (2) 12mm Hex Bolts, (4) 12mm Flat Washers, (2) 12mm Lock Washers and (2) 12mm Hex Nuts, **(Figure 16)**. Do not tighten hardware.
15. Slowly open tailgate and check for clearance. Level and adjust the Bumper and tighten all hardware.
16. **For models with bed Guards** attach the Bumper the bed guards with (2) 10mm Double Nut Plates, (4) 10mm Hex Bolts, (4) 10mm Lock Washers and (4) 10mm Flat Washers.
17. Install the license plate lights.
18. Reattach the towing harness plug (if equipped) into the Bumper.
19. Attach the (2) Tow Hooks to the Bumper, **(Figure 17)**.
20. Attach the license plate to the (2) holes in the Bumper with the included (2) 6mm Screws, (4) 6mm Flat Washers, (2) 6mm Lock Washers and (2) 6mm Hex Nuts. **(Figure 18)**.

21. Reattach to wiring harnesses.

22. Do periodic inspections to the installation to make sure that all hardware is secure and tight.

To protect your investment, Do not use any type of polish or wax that may contain abrasives that could damage the finish. Mild soap may be used to clean the Bumper assembly.

Driver/Left Side Installation Pictured

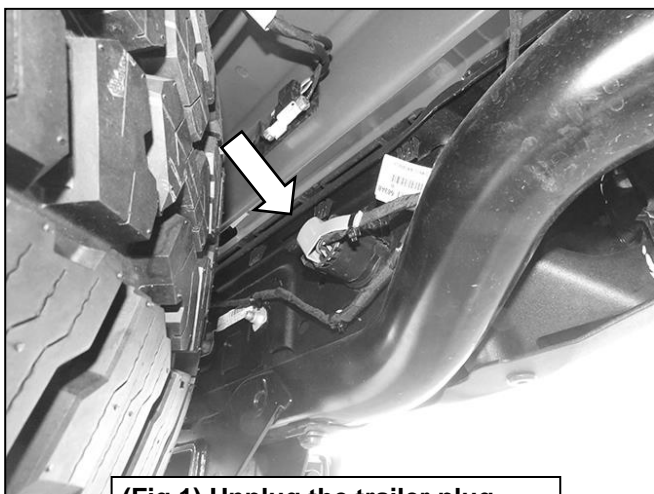

(Fig 1) Unplug the trailer plug, License plate lights and sensors

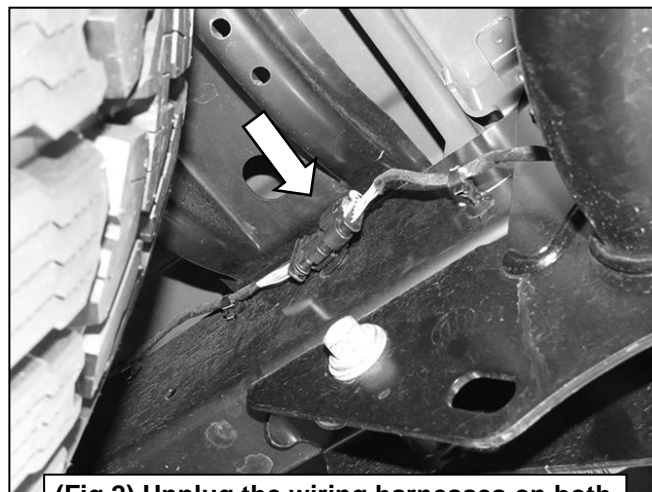

(Fig 2) Unplug the wiring harnesses on both sides of the frame that leads to the bumper



(Fig 3) Remove the (2) bolts under the receiver hitch

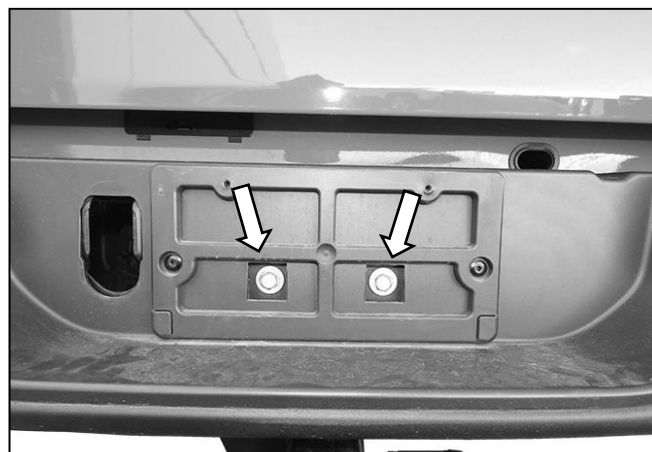

(Fig 4) Remove the (2) bolts under the license plate

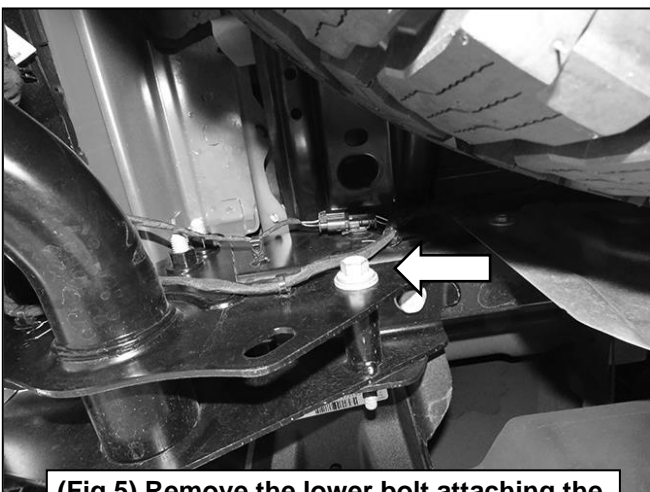

(Fig 5) Remove the lower bolt attaching the rock rail (if equipped) to the receiver hitch

Driver/Left Side Installation Pictured



(Fig 6) Remove the (2) upper bolts attaching the rock rail (if equipped) to the receiver hitch

WARNING! Do not remove bumper bolts unless the bumper is properly supported on blocks or stands or the bumper may fall.

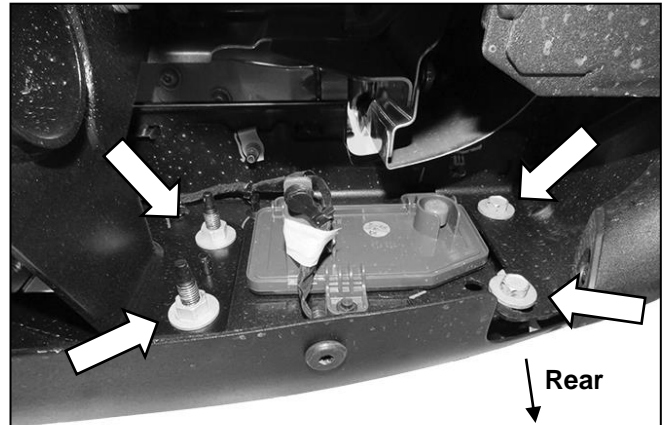

(Fig 7) Remove the bolts to rock rail (if equipped). Remove the factory nuts to remove the bumper



(Fig 8) Factory bumper removed

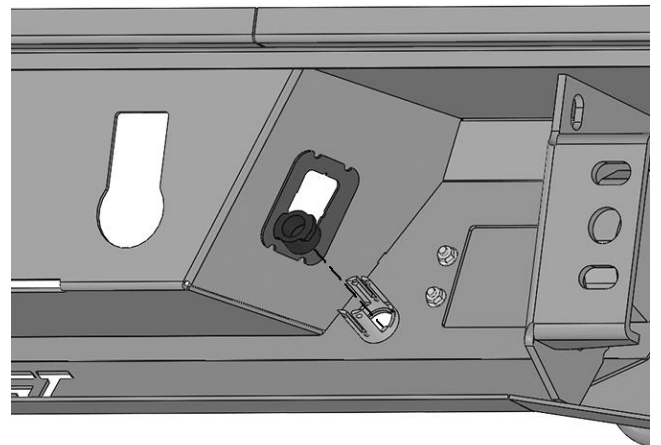

(Fig 9) Push Sensor Plug into mounting sleeve (Optional, use 4mm Screws to lock plug in place)

Driver/Left Side Installation Pictured

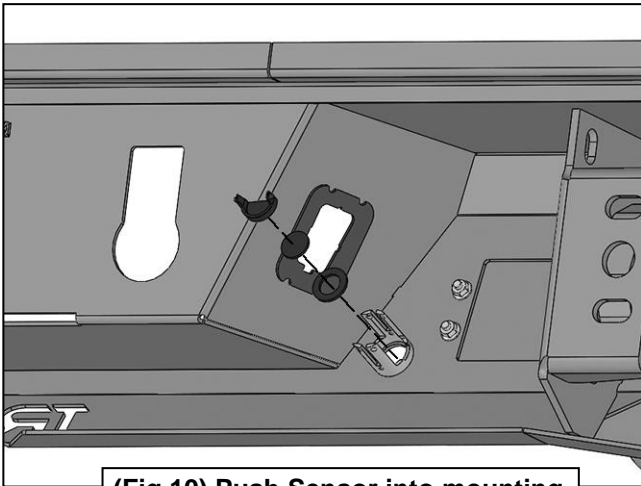

(Fig 10) Push Sensor into mounting sleeve (Optional, use 4mm Screws to lock sensor in place)

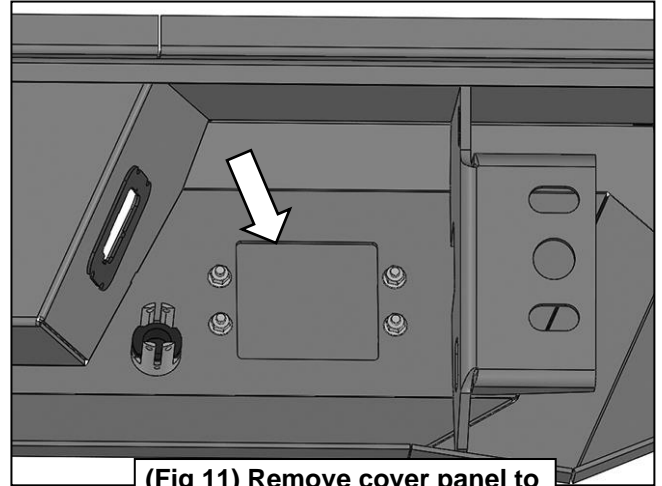

(Fig 11) Remove cover panel to install light (light not included)

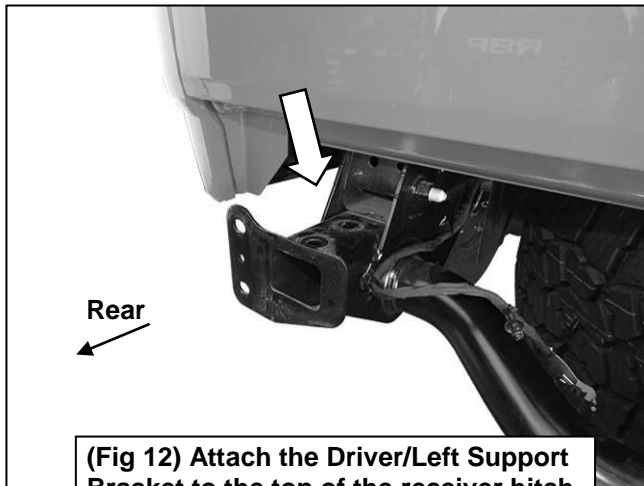

Rear

(Fig 12) Attach the Driver/Left Support Bracket to the top of the receiver hitch, (behind the bumper mounting plate)

- (2) 12mm Hex Bolts
- (4) 12mm Flat Washers
- (2) 12mm Lock Washers
- (2) 12mm Hex Nuts

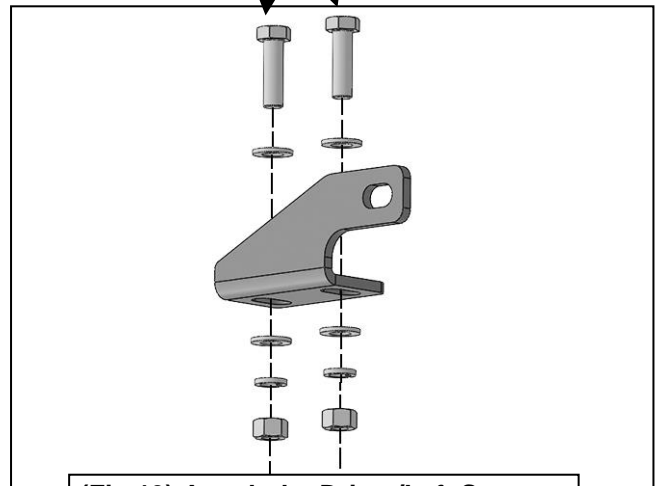

(Fig 13) Attach the Driver/Left Support Bracket to the top of the receiver hitch

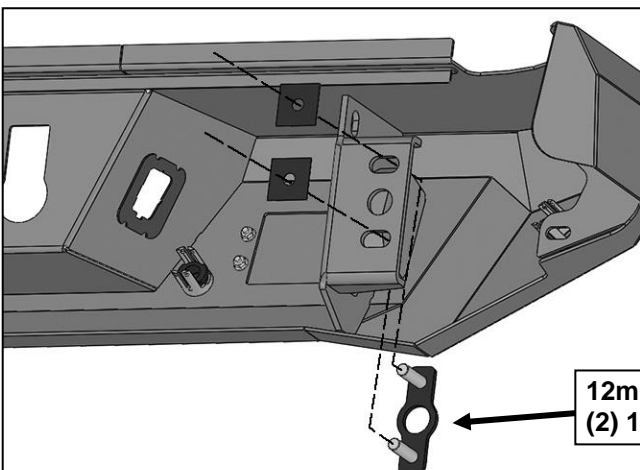

- 12mm Double Bolt Plate
- (2) 12mm Plastic Retainers

(Fig 14) Insert (1) 12mm Double Bolt Plate into the back of the bumper. Thread (2) Plastic Retainers onto the bolt plate to hold in place

Driver/Left Side Installation Pictured

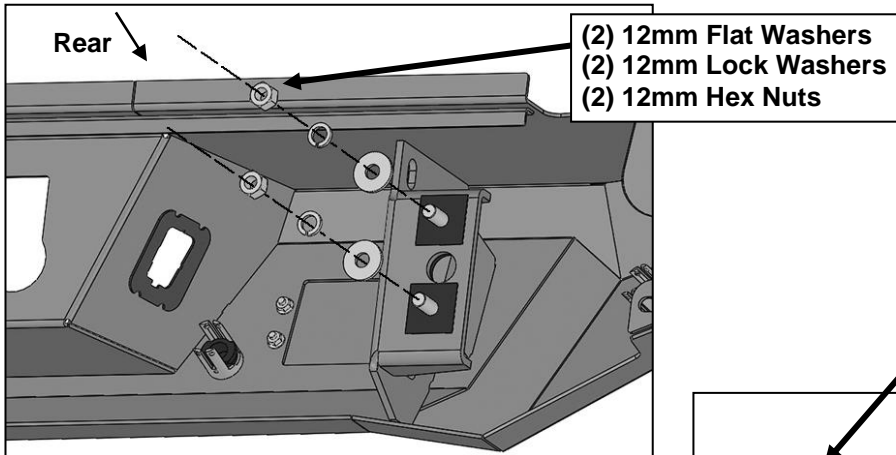

(Fig 15) Attach the Bumper to the receiver hitch

WARNING! Do not crawl under bumper unless the bumper is properly supported on blocks or stands or the bumper may fall.

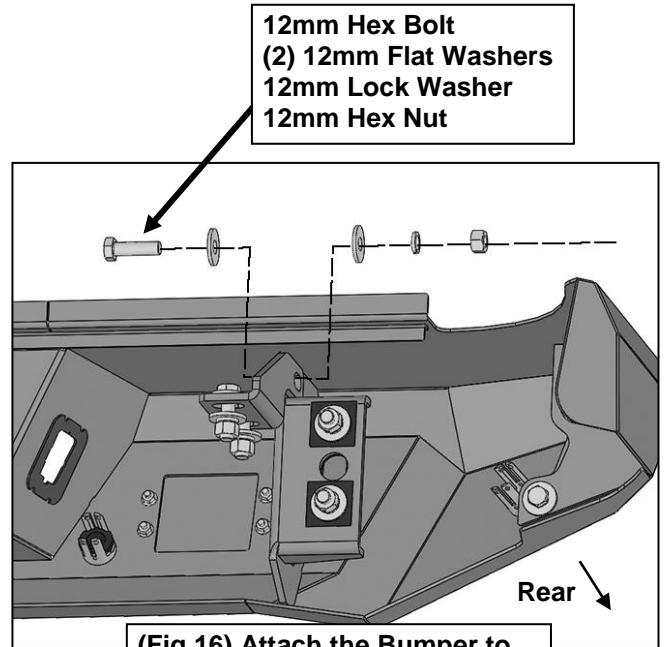

(Fig 16) Attach the Bumper to the Driver/Left Support Bracket

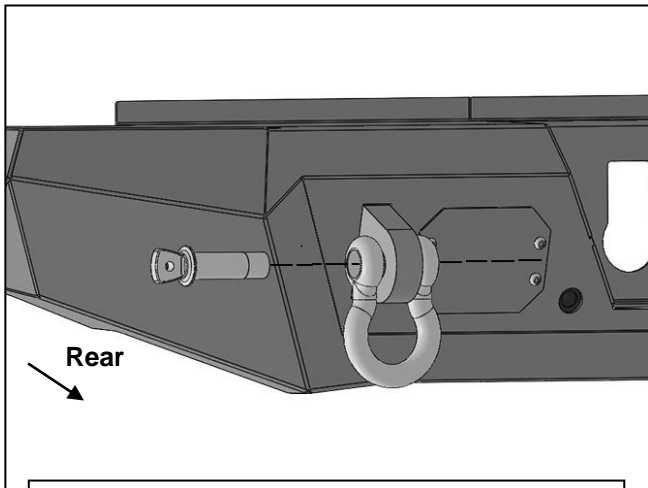

(Fig 17) Attach the Tow Hooks to the Bumper

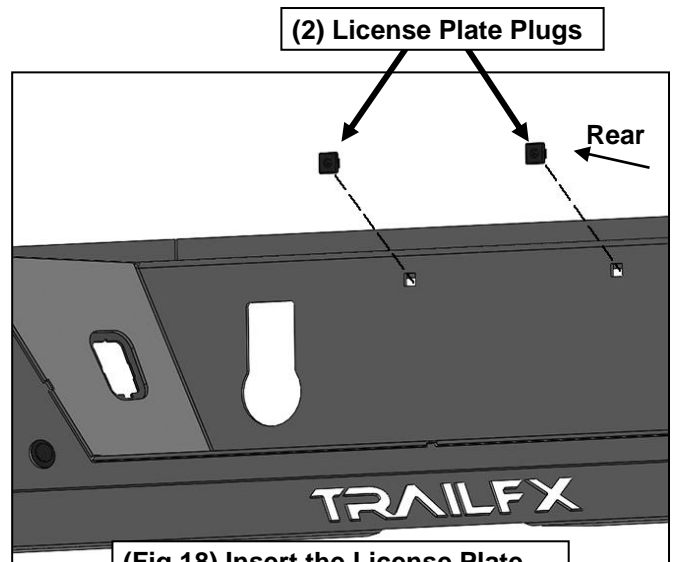

(Fig 18) Insert the License Plate Plugs into the front of the Bumper

PRODUCT CARE

- Periodically check the product to ensure all fasteners are tight and components are intact.
- Regular waxing is recommended to protect the finish of the product.
- **Use ONLY Non-Abrasive automotive wax.** Use of any soap, polish or wax that contains an abrasive is detrimental and can scratch the finish leading to corrosion.
- Aluminum polish may be used to polish small scratches and scuffs for **Stainless Steel finish.**
- Mild soap may be used to clean the product for both **Stainless Steel and Black finish.**

FAQ's

1. Hardware's are not of correct size.

In GMC / Chevrolet truck model 2006 & up, customer needs to reuse the factory body bolts to install the bracket. If your vehicle is not GMC / Chevrolet 2006 & up, ensure that holes are not partially covered with any plastic grommet or rust? If it is, remove the plastic grommet & rust from the thread holes & re-try the installation.

2. Mounting Bracket are not getting Installed properly.

In some cases Illustration images shown in Installation manual may not be the exactly same as per actual vehicle images ,also if Driver / Passenger side mounting brackets are very identical in the design, suggest referring Parts Identification guide to avoid fitment issue.

3. Products are thumping / rattling after installation.

Ensure that all required mounting brackets / hardware's are installed & tighten correctly. Suggest using white lithium / regular grease between the metal to metal contact surfaces.

4. Side Bar is not aligning with vehicle / Step Pads are not aligning with vehicle doors.

Side bar may be interchanged or mounting brackets are not installed at the correct position in the vehicle. Refer Parts identification guide.

5. Missing / Excess Hardware.

Recheck hardware count as per the part list.

6. Product not installing properly.

Ensure make model year, cab length and bed size of your vehicle is listed in the application. All installation steps are followed correctly.

Check out these other TrailFX Products!!

www.TrailFX.com



BULL BAR



GRILLE GUARDS



BED RAILS



RUNNING BOARDS

Keystone Automotive Operations Inc. (KAO) warrants this product to be free of defects in material and workmanship at the time of purchase by the original retail consumer. KAO disclaims any other warranties, express or implied, including the warranty of fitness for a particular purpose or an intended use. If the product is found to be defective, KAO may replace or repair the product at our option, when the product is returned prepaid, with proof of purchase. Alteration to, improper installation, or misuse of this product voids the warranty. KAO's liability is limited to repair or replacement of products found to be defective, and specifically excludes liability for any incidental or consequential loss or damage.