



# Running Board

## Part No. R0011MK



Fits: **2011 - Current**  
**2011 - Current**

**Dodge Durango**  
**Jeep Grand Cherokee (Excl. SRT and Trail Hawk models)**



60-180 min

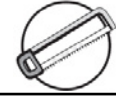

Cutting Required



Drilling Not Required



REMOVE CONTENTS FROM BOX. VERIFY ALL PARTS ARE PRESENT.



READ INSTRUCTIONS CAREFULLY BEFORE STARTING INSTALLATION.

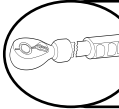

DO NOT OVER TORQUE. STANDARD OPERATING LOAD FOR TIGHTEN BODY MOUNT NUTS & BOLTS VARIES FROM **45** TO **65** FOOT POUND.

### PARTS LIST:

| Qty | Part Description                    | Qty | Part Description                       |
|-----|-------------------------------------|-----|--|
| 2   | Running Boards                      | 12  | 6mm "T" Bolts                          |
| 6   | Mounting Brackets                   | 12  | 6-1.0mm x 25mm Hex Bolts               |
| 6   | 12-1.75mm x 40mm Bolt Plates        | 24  | 6mm x 22mm OD x 2mm Large Flat Washers |
| 6   | 12mm Serrated Flange Nuts           | 12  | 6mm x 18mm OD x 1.6mm STD Flat Washers |
| 6   | 12mm x 24mm OD x 2.5mm Flat Washers | 12  | 6mm Lock Washers                       |
| 6   | 12mm Plastic Retainers              | 12  | 6mm Hex Nuts                           |
|     |                                     | 12  | 6mm Nylon Lock Nuts                    |

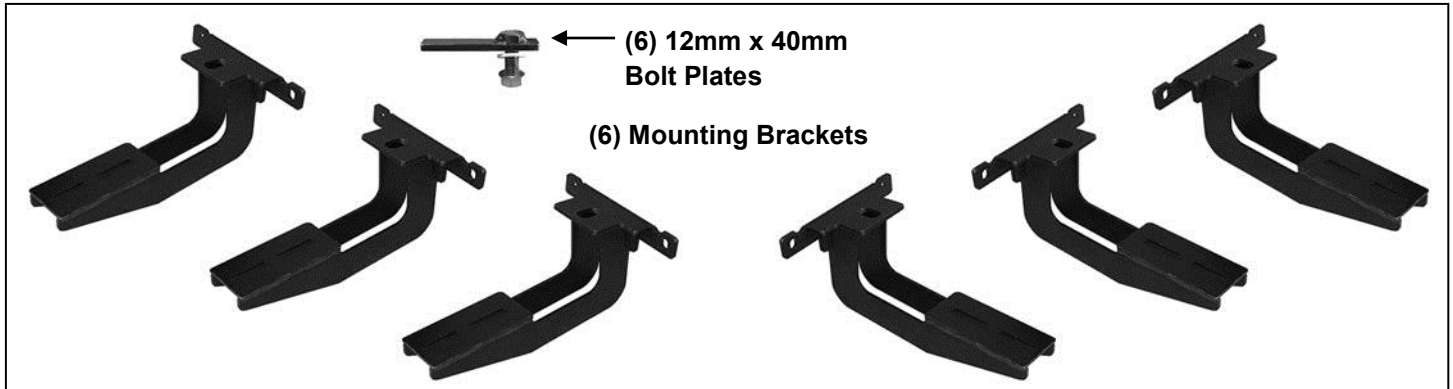

### INSTALLATION PROCEDURE

**RUNNING BOARDS ARE NOT COMPATIBLE WITH "ROCK RAIL" ROCKER PANEL GUARDS.**

- Starting at the driver side, locate the (3) pairs of factory holes in the pinch weld, **(Figure 1 & 2)**. Move toward the front pair. Remove the rubber plug filling the oval hole in the bottom of the rocker panel in front of the two holes, **(Figure 3)**. Select (1) 12mm Bolt Plate and (1) 12mm Plastic Retainer. Partially thread the Retainer onto the Bolt Plate. Insert the Bolt Plate into the hole and rotate it 90-degrees to go across the slot, **(Figure 4)**. Thread the Retainer all the way down the Bolt Plate and tight against the body panel, **(Figure 5)**. **NOTE:** The Plastic Retainer is designed to prevent the Bolt Plate from pushing up into the body panel and to aid in Bracket installation.

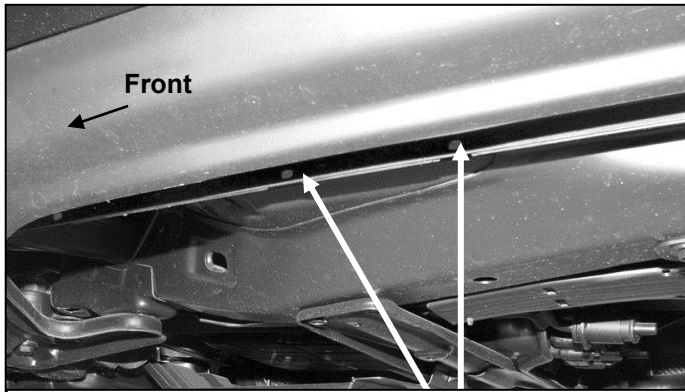

(Fig 1) Driver side front mounting location pictured

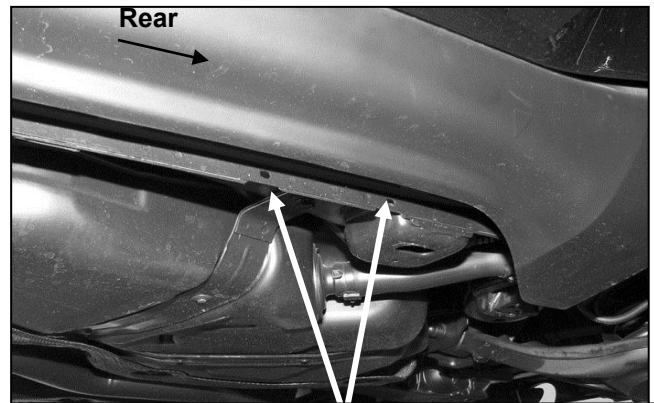

(Fig 2) Driver side rear mounting location pictured

**Remove rubber plugs**

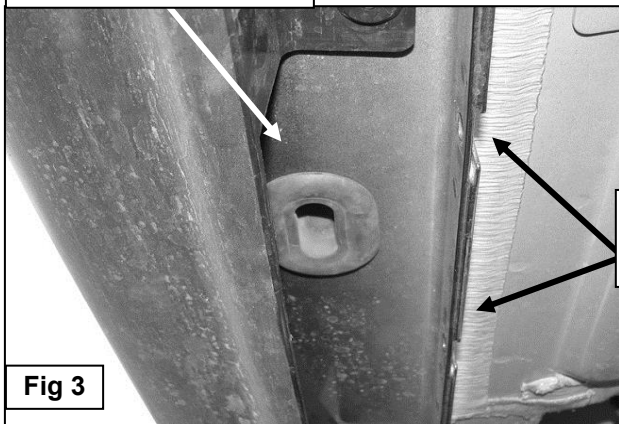

**Fig 3**

2. Select (1) Mounting Bracket and secure it to the Bolt Plate with (1) 12mm x 24mm Flat Washer and (1) 12mm Serrated Flange Nut, **(Figure 6)**. Do not tighten hardware at this time.
3. Line up the (2) small slots in the Bracket with the (2) holes in the pinch weld. Insert (1) 6mm x 25mm Hex Bolt with (1) 6mm x 18mm STD Flat Washer through the pinch weld and then the Bracket. Secure the Bracket to the Hex Bolt with (1) 6mm x 22mm Large Flat Washer and (1) 6mm Nylon Lock Nut over the Bracket, **(Figures 6 & 9)**. Do not tighten hardware at this time. Repeat for remaining mounting hole in Bracket and pinch weld. **NOTE:** Insert 6mm Hex Bolts with STD Flat Washers through the back of the pinch weld first, and then out through the Bracket.
  - a. **IMPORTANT:** The passenger side of the vehicle may have a wiring harness attached behind the pinch weld, **(Figure 7)**. Remove the hex nuts and drop the harness down before installing the Brackets, **(Figure 8)**. 6mm Hex Bolts install from the inside first, then through the Bracket to clear the harness, **(Figure 9)**. Snug but do not fully tighten hardware at this time.
4. Repeat **Steps 1—3** to install the center and rear Brackets, **(Figure 9)**.

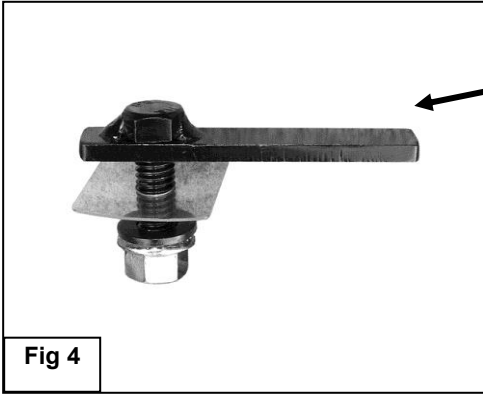

- (1) 12mm x 40mm Bolt Plate
- (1) 12mm Plastic Retainer
- (1) 12mm x 24mm Flat Washer
- (1) 12mm Flange Nut

After inserting, rotate Bolt Plate 90-degrees to go across the slot or until Bolt Plate stops

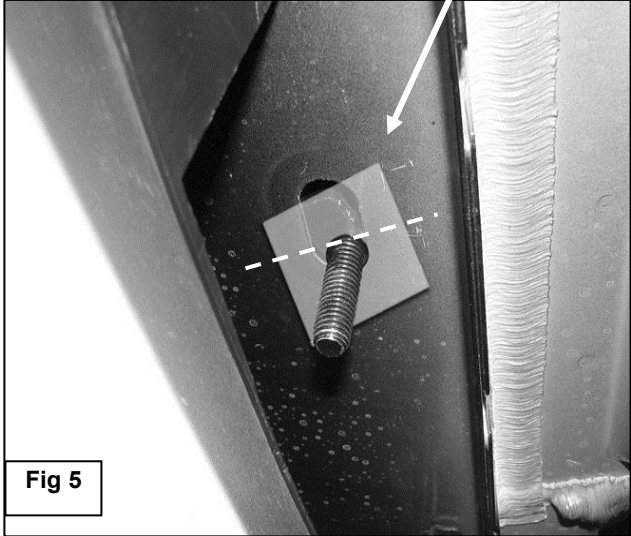

- 6mm x 25mm Hex Bolts
- 6mm x 18mm STD Flat Washers

- 6mm x 22mm Large Flat Washers
- 6mm Nylon Lock Nuts

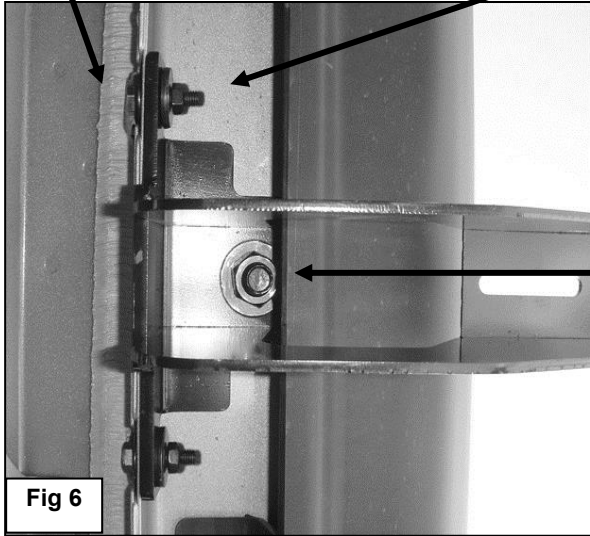

- (1) 12mm x 24mm Flat Washer
- (1) 12mm Flange Nut

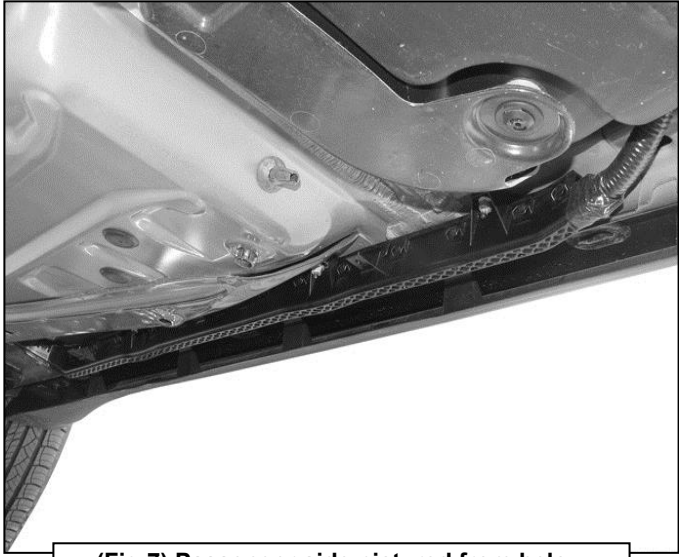

(Fig 7) Passenger side pictured from below



(Fig 8) Passenger side pictured

Remove hex nuts from wiring harness. Drop harness down to install Brackets.

5. Select (1) Running Board. Insert (6) 6mm T-Bolts into the open ends of the channels, (3 T-Bolts per channel), in the bottom of the Running Board, **(Figure 10)**. Slide the T-Bolts into the approximate position in line with the (3) Brackets. Carefully place the Running Board in position on top of the Brackets. Slide the T-Bolts forward or back until they line up and drop into the slots on the Brackets. **NOTE:** It may be necessary to lower the Brackets to insert the Running Board between the Brackets and the vehicle. Loosen hardware as necessary.
6. Secure the Running Board to the Brackets with (6) 6mm x 22mm Large Flat Washers, (6) 6mm Lock Washers and (6) 6mm Hex Nuts, **(Figure 11)**. Do not tighten hardware at this time.
7. Adjust and level the Running Board and tighten all hardware.
8. Repeat **Steps 1—7** for passenger/right Running Board installation. See important information in **Step 3**.
9. Do periodic inspections to the installation to make sure that all hardware is secure and tight.

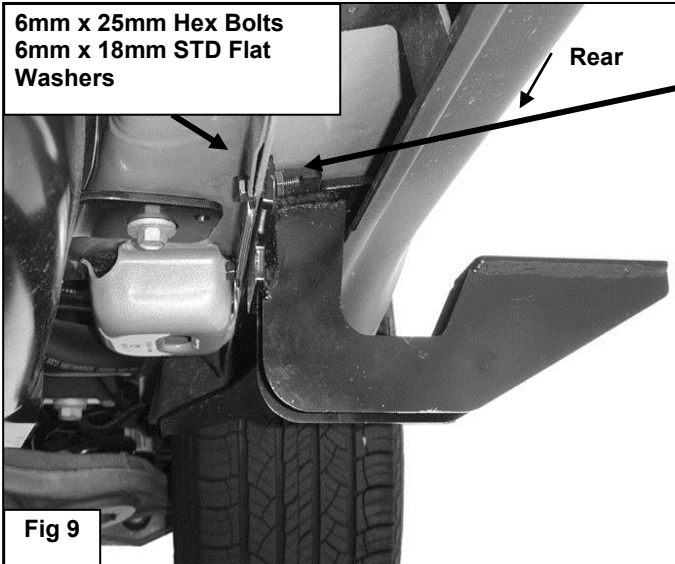

6mm x 22mm Large Flat Washers  
6mm Nylon Lock Nuts

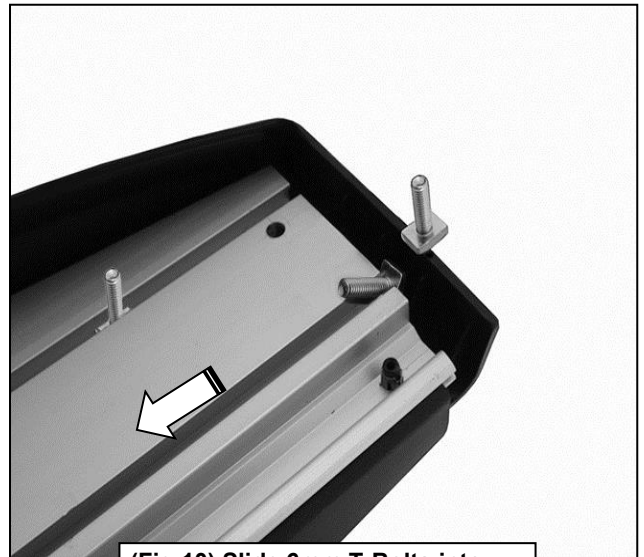

6mm x 22mm Large Flat Washer  
6mm Lock Washer  
6mm Hex Nut



## PRODUCT CARE

- Periodically check the product to ensure all fasteners are tight and components are intact.
- Regular waxing is recommended to protect the finish of the product.
- **Use ONLY Non-Abrasive automotive wax.** Use of any soap, polish or wax that contains an abrasive is detrimental and can scratch the finish leading to corrosion.
- Aluminum polish may be used to polish small scratches and scuffs for **Stainless Steel finish.**
- Mild soap may be used to clean the product for both **Stainless Steel and Black finish.**

## FAQ's

**1. Hardware's are not of correct size.**

*In GMC / Chevrolet truck model 2006 & up, customer needs to reuse the factory body bolts to install the bracket. If your vehicle is not GMC / Chevrolet 2006 & up, ensure that holes are not partially covered with any plastic grommet or rust? If it is, remove the plastic grommet & rust from the thread holes & re-try the installation.*

**2. Mounting Bracket are not getting Installed properly.**

*In some cases Illustration images shown in Installation manual may not be the exactly same as per actual vehicle images ,also if Driver / Passenger side mounting brackets are very identical in the design, suggest referring Parts Identification guide to avoid fitment issue.*

**3. Products are thumping / rattling after installation.**

*Ensure that all required mounting brackets / hardware's are installed & tighten correctly. Suggest using white lithium / regular grease between the metal to metal contact surfaces.*

**4. Side Bar is not aligning with vehicle / Step Pads are not aligning with vehicle doors.**

*Side bar may be interchanged or mounting brackets are not installed at the correct position in the vehicle. Refer Parts identification guide.*

**5. Missing / Excess Hardware.**

*Recheck hardware count as per the part list.*

**6. Product not installing properly.**

*Ensure make model year, cab length and bed size of your vehicle is listed in the application. All installation steps are followed correctly.*