

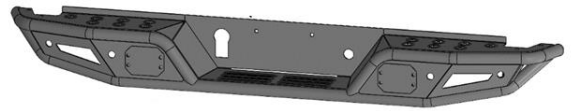

NB3 REAR BUMPER

Part No. RPRB001TI



Fits: 2016-2019 TOYOTA TACOMA



Including Diesel models with DEF tanks



60-180 min

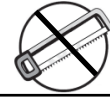

Cutting is not Required



Drilling is not Required



REMOVE CONTENTS FROM BOX. VERIFY ALL PARTS ARE PRESENT.



READ INSTRUCTIONS CAREFULLY BEFORE STARTING INSTALLATION.

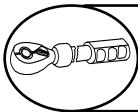

DO NOT OVER TORQUE. STANDARD OPERATING LOAD FOR TIGHTEN BODY MOUNT NUTS & BOLTS VARIES FROM 45 TO 65 FOOT POUND.

PARTS LIST:

Qty	Part Description	Qty	Part Description
1	NB3 Rear Bumper	4	12mm x 24mm x 2.5mm Flat Washers
1	Driver/Left Cover Plate	4	12mm Lock Washers
1	Passenger/Right Cover Plate	6	12mm Nylon Lock Nuts
1	Driver/Left Mounting Bracket	4	8-1.25mm x 20mm Hex Bolts
1	Passenger/Right Mounting Bracket	4	8mm x 16mm x 1.6mm Flat Washers
2	License Plate Plugs	4	8mm Flanged Hex Nuts
4	Sensor Hole Plugs	8	4mm x 10mm Button Head Bolts
1	Sensor Cover Kit	1	4mm Hex Wrench
6	12-1.75mm x 40mm Coarse Thread Hex Bolts	1	2.5mm Hex Wrench
4	12-1.25mm x 45mm Fine Thread Hex Bolts	10	Nylon Ties
12	12mm x 32mm x 3mm Flat Washers		

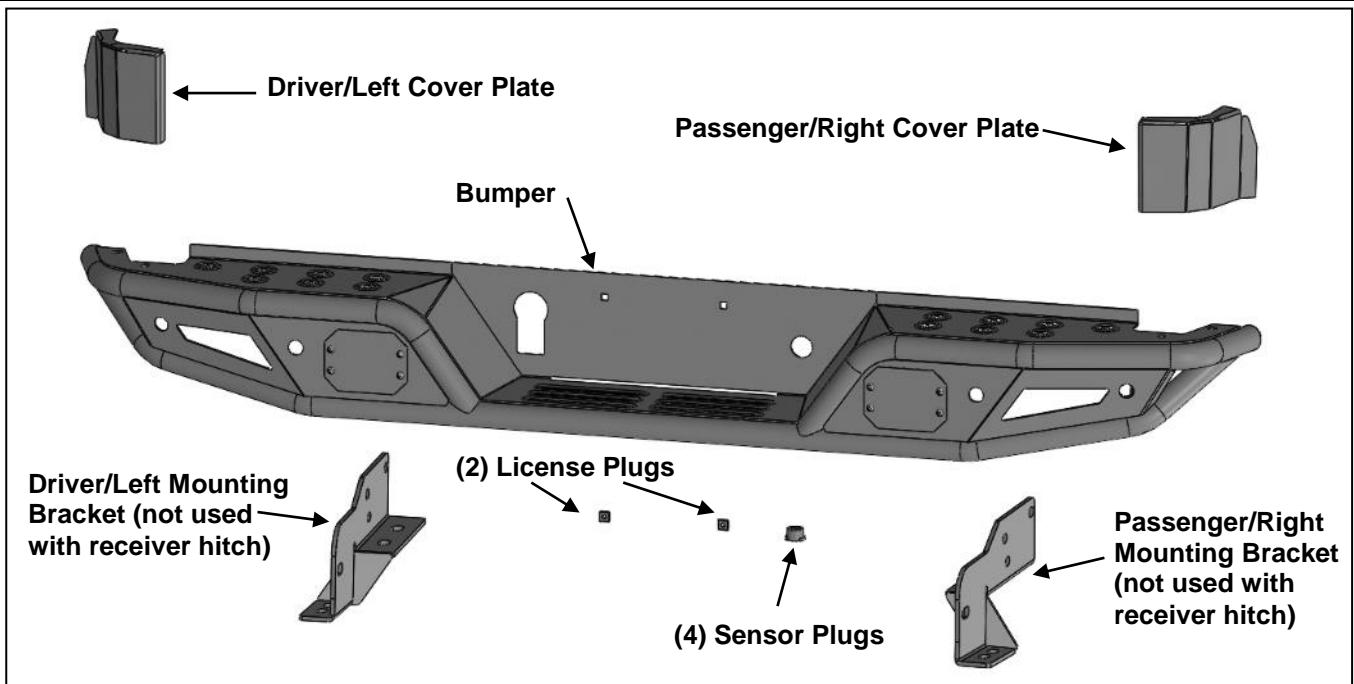

PROCEDURE:

REMOVE CONTENTS FROM BOX. VERIFY ALL PARTS ARE PRESENT. READ INSTRUCTIONS CAREFULLY BEFORE STARTING INSTALLATION. BUMPER IS DESIGNED TO INSTALL WITH FACTORY

RECEIVER HITCH, AFTERMARKET RECEIVER HITCH MAY INTERFERE WITH INSTALLATION. BUMPER IS HEAVY, ASSISTANCE IS RECOMMENDED TO AVOID POSSIBLE INJURY OR DAMAGE TO THE VEHICLE.

1. Locate BSM (Blind Spot Monitor) button underneath the radio display to turn off and RCTA (Rear Cross Traffic Alert) Systems, (if equipped). Next, unplug the wire harnesses from the (2) monitor sensors located on the sides of the Rear Bumper. **NOTE:** The BSM and RCTA systems will not work with Bumper installation, monitor sensors cannot be reinstalled.
2. Unplug the wiring harness leading to the bumper, (**Figure 1**). Move all wiring harnesses away from bumper.
3. **Determine if vehicle is equipped with factory receiver hitch**

Models without receiver hitch:

- a. Place blocks or jack stands under the bumper to support it during mounting bolt removal. Once the bumper has been safely supported, remove the factory hex bolts attaching the bumper brackets to the sides and bottom of the frame and slide the bumper assembly off of the vehicle.

Models with factory receiver hitch:

- a. Remove the plastic cover from the top of the bumper, (**Figure 2**). **NOTE:** Cover is attached at top, back and bottom by several plastic clips. Remove these pins to release plastic cover.
- b. Place blocks or jack stands under the bumper to support it during mounting bolt removal. Once the bumper has been safely supported, remove the factory hardware attaching the bumper to the top and bottom of the receiver hitch and remove the bumper, (**Figures 3 & 4**). **NOTE:** Leave hitch attached to vehicle.

4. Remove the trailer plug and sensors and wiring harness, (if equipped), from bumper.

5. **Optional Light installation** (Light not included).

- a. Remove the block off panels located on the Bumper, (**Figure 5**).
- b. Follow instructions included with lights to attach to Bumper, (lights not included).

6. Depending on tow package, it may be necessary or easier to install sensors at this time, (if equipped), before installing the Bumper.

Models without bumper sensors:

- a. Select (4) Rubber Plugs.
- b. From behind bumper, push plugs into sensor mounting holes, (**Figure 6**).

Models with bumper mounted back-up sensors:

- a. Remove sensors and wiring harness from the back of the factory bumper.
- b. Select (1) sensor. Insert the sensor into the mounting sleeve in the back of the bumper.
- c. Secure sensor to the sleeve with (2) 4mm x 10mm Button Head Screws, (**Figure 7**). **IMPORTANT:** Sensors fit snug in sleeves. The 4mm Bolts are used to apply slight pressure to lock the sensors in place. Tighten both screws evenly until they touch the sensor body only. Do not overtighten screws or damage to sensors will result.
- d. Repeat **Steps 6a & 6b** to install the remaining (3) sensors.

7. Attach the wiring harness to the sensors and trailer plug. Use the included Wire Ties to secure the wiring harness to the bumper and frame as necessary.

8. Select the Driver/Left Cover Plate. Attach the Plate to the top Driver/Left side of the Bumper with (2) 8mm Hex Bolts, (2) 8mm Flat Washers and (2) 8mm Flanged Hex Nuts, (**Figure 8**). Repeat this **Step** to attach the Passenger/Right Cover Plate to the Bumper

9. **Models without factory receiver hitch only, (models with hitch, skip to Step 10):**

- a. Select the Driver/Left Mounting Bracket. Attach the Driver/Left Mounting Bracket to the sides and bottom of the frame with (3) factory bolts, (**2**) 12-1.25mm x 45mm Fine Thread Hex Bolts, (2) 12mm Lock Washers and (2) 12mm x 32mm Flat Washers, (**Figures 9 & 10**). Do not tighten hardware at this time.

- b. Repeat **Step 9a** to install the Passenger/Right Mounting Bracket.

10. With assistance, hold the NB3 Bumper up to the Brackets or receiver hitch. Temporarily support the weight of the Bumper. **WARNING:** To avoid possible injury or damage to the vehicle, do not proceed until the bumper is fully and safely supported.

11. Attach the Bumper to the bottom of the Driver/Left Bracket or to the hitch with the included (2) 12mm x 40mm Coarse Thread Hex Bolts, (2) 12mm x 32mm Flat Washers (bottom), (2) 12mm x 24mm Flat Washers (top), and (2) 12mm Nylon Lock Nuts, (**Figures 11—14**). Do not fully tighten hardware at this time. Repeat this **Step** to attach the Bumper to the Passenger/Right Mounting Bracket.

12. Next, attach the bumper to the side of the Driver/Left Mounting Bracket slot or upper hitch slot with (1) 12mm x 40mm Coarse Thread Hex Bolts, (2) 12mm x 32mm Large Flat Washers and (1) 12mm Nylon Lock Nuts, (**Figures 11—14**). Repeat this **Step** for the Passenger/Right Mounting Bracket.

13. Open tailgate and check for clearance. Level and adjust the bumper and fully tighten all hardware.

14. Plug wiring harness into the main harness.
15. Use the included (2) push-in plugs to attach the license plate to the Bumper, **(Figure 15)**. Insert the factory license plate light into the hole in the step area. Connect the harness to the license plate light.
16. Do periodic inspections to the installation to make sure that all hardware is secure and tight.

To protect your investment, Do not use any type of polish or wax that may contain abrasives that could damage the finish. Mild soap may be used to clean the Bumper assembly.

Driver/Left Side Installation Pictured



(Fig 1) Unplug and remove trailer plug, unplug license plate lights and sensors if equipped



Rear
↓

(Fig 2) Models with receiver hitch, remove plastic cover from top of bumper

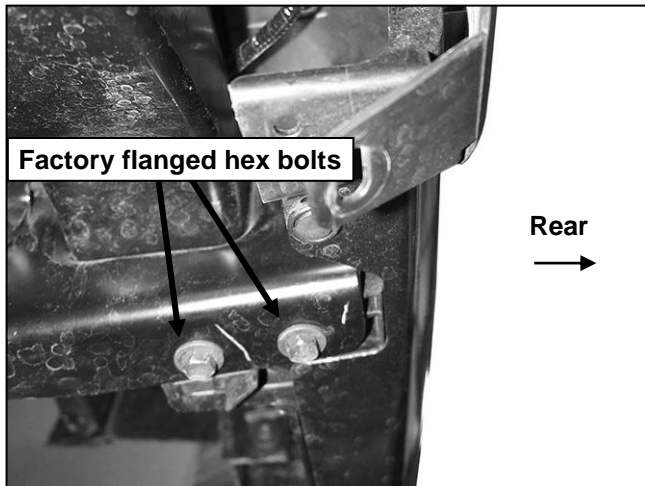

Factory flanged hex bolts

Rear
→

(Fig 3) Models with receiver hitch, remove the hex bolts attaching bottom of bumper

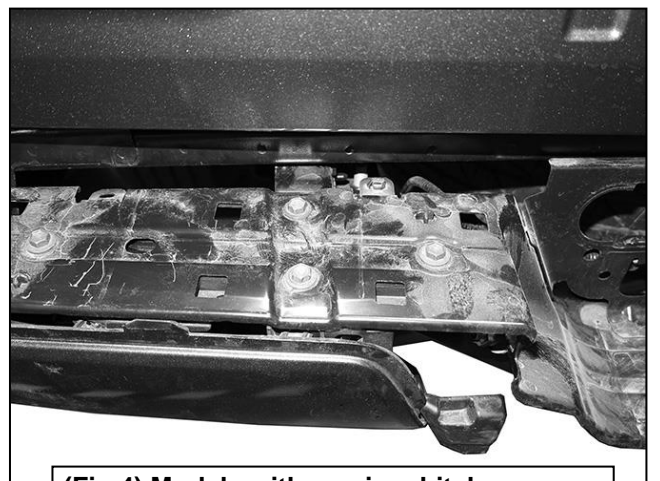

(Fig 4) Models with receiver hitch, remove the hex bolts attaching top of bumper

WARNING! Do not remove bumper bolts unless the bumper is properly supported on blocks or stands or the bumper may fall.

Driver/Left Side Installation Pictured

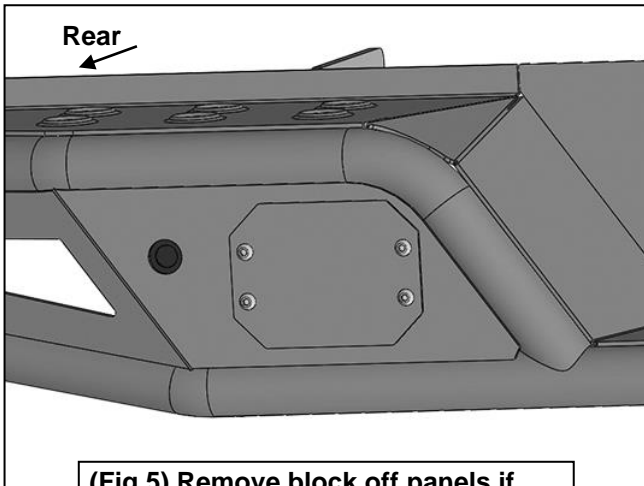

(Fig 5) Remove block off panels if lights (not included) will be installed

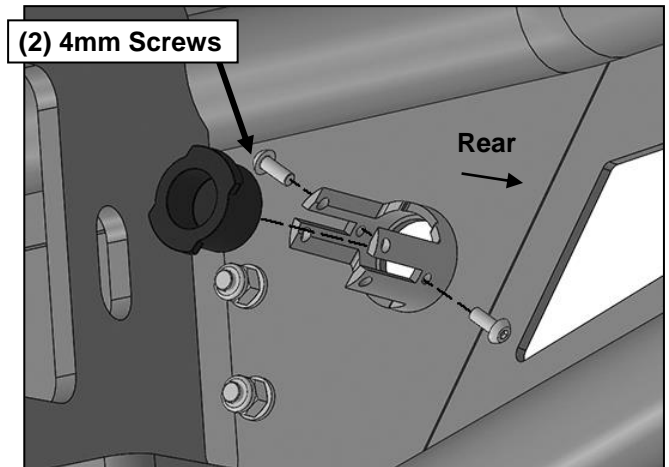

(2) 4mm Screws

(Fig 6) Push Sensor Plug into mounting sleeve.

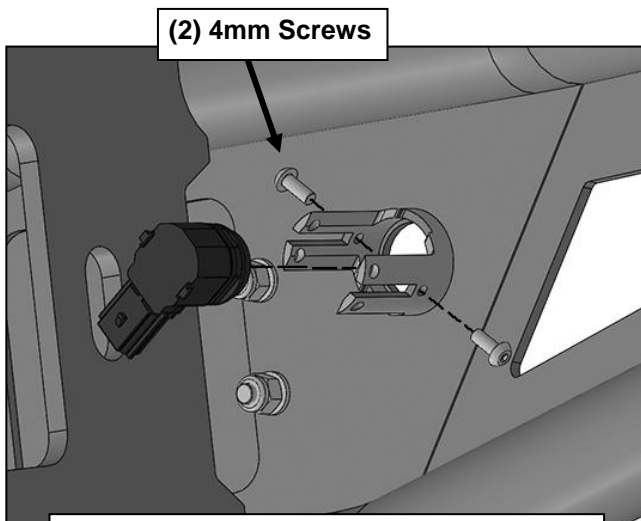

(2) 4mm Screws

(Fig 7) Push Sensor into mounting sleeve. Use 4mm Screws to lock sensor in place

(2) 8mm Hex Bolt
(2) 8mm Flat Washers
(2) 8mm Flanged Hex Nuts

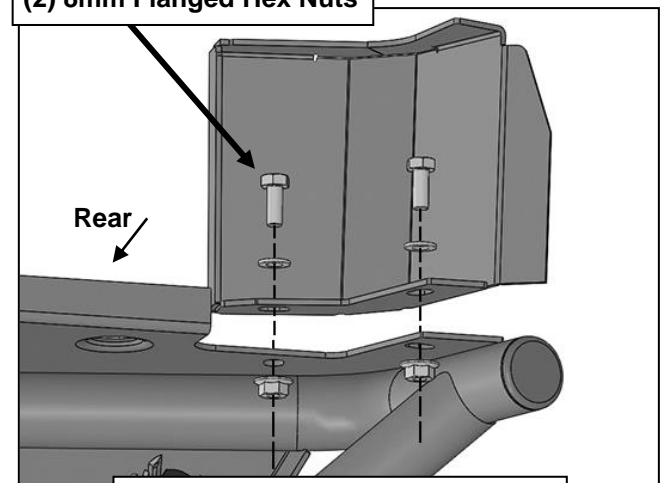

(Fig 8) Attach Driver/Left Cover Plate to the top left of the Bumper

Driver/Left Side Installation Pictured

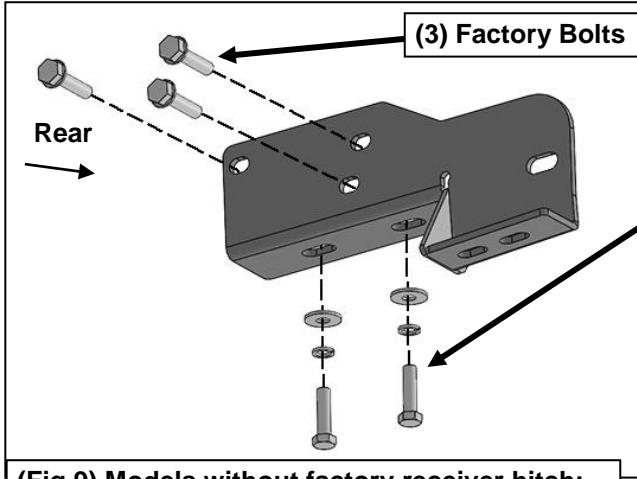

- (2) 12-1.25mm x 45mm Fine Thread Hex Bolts
- (2) 12mm Lock Washers
- (2) 12mm x 32mm Flat Washers

(Fig 9) Models without factory receiver hitch: Reuse factory hex bolts to attach Mounting Bracket to side of frame. Use 12-1.25mm Fine Thread bolts on the bottom of the Bracket

- (2) 12mm x 40mm Coarse Thread Hex Bolts
- (2) 12mm x 24mm Flat Washers (top)
- (2) 12mm x 32mm Flat Washers (bottom)
- (2) 12mm Nylon Lock Nuts

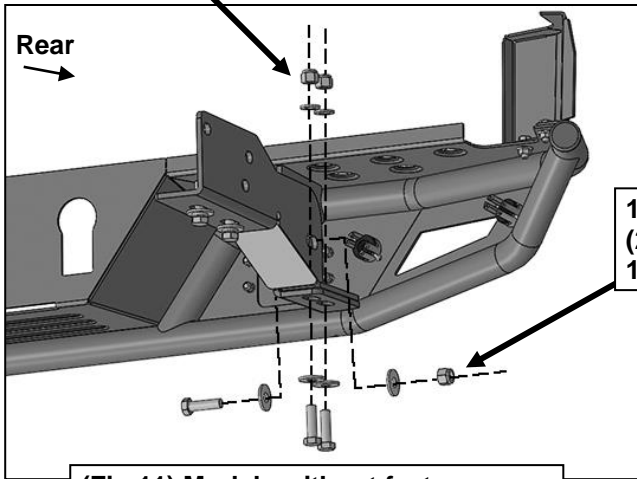

(Fig 11) Models without factory receiver hitch: Attach Bumper to side and bottom of Mounting Bracket

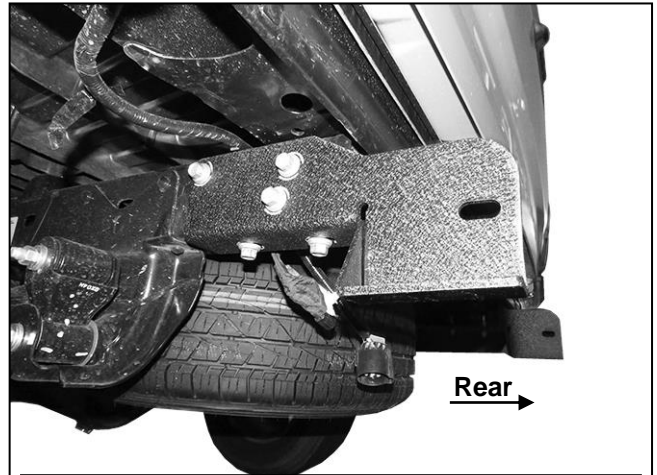

(Fig 10) Driver/Left Mounting Bracket attached

- 12mm x 40mm Coarse Thread Hex Bolt
- (2) 12mm x 32mm Flat Washers
- 12mm Nylon Lock Nut



(Fig 12) Bumper attached to Mounting Bracket

Driver/Left Side Installation Pictured

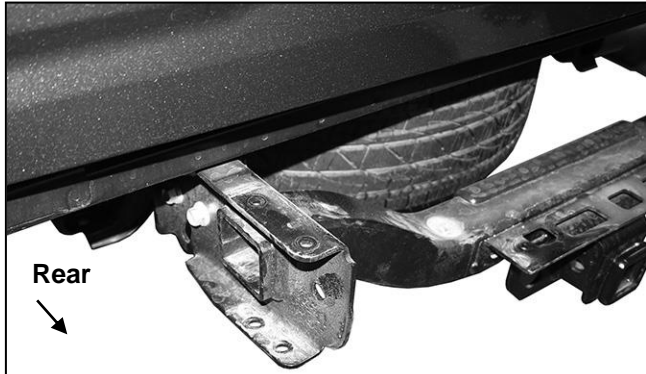

(Fig 13) Model with factory receiver hitch

- (2) 12mm x 40mm Coarse Thread Hex Bolts
- (2) 12mm x 24mm Flat Washers (top)
- (2) 12mm x 32mm Flat Washers (bottom)
- (2) 12mm Nylon Lock Nuts

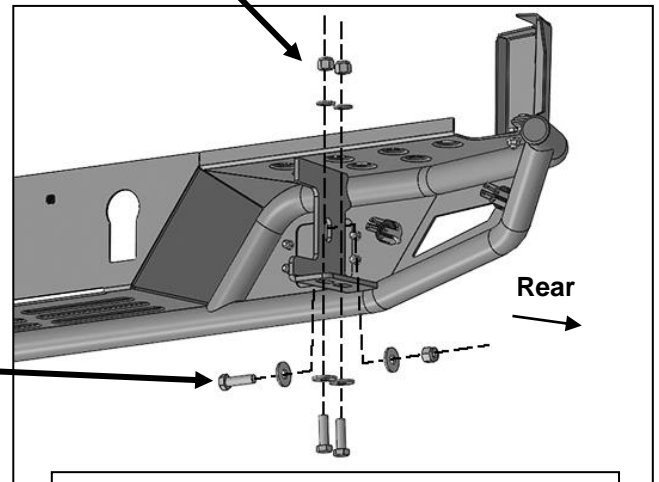

- 12mm x 40mm Coarse Thread Hex Bolt
- (2) 12mm x 32mm Flat Washers
- 12mm Nylon Lock Nut

**(Fig 14) Model with factory receiver hitch:
Attach Bumper to side and bottom of hitch**

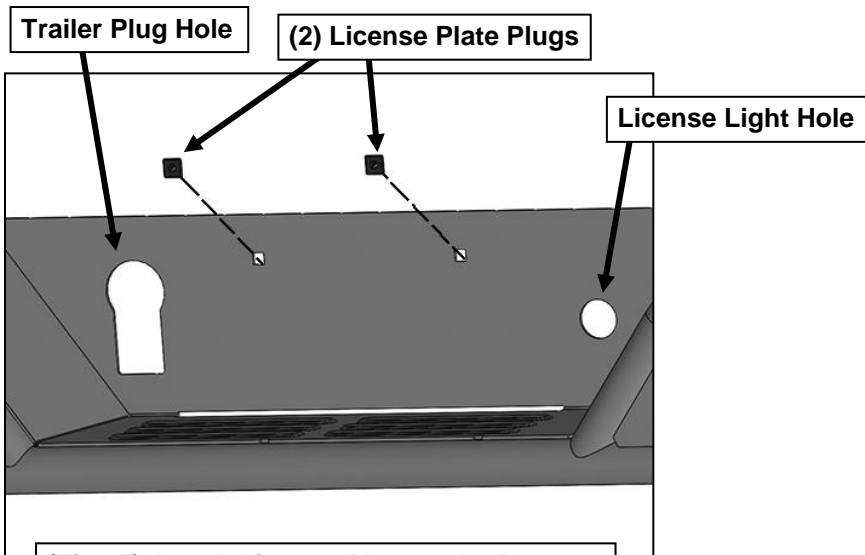

(Fig 15) Attach License Plate to the Bumper

PARTS IDENTIFICATION GUIDE

Driver Side tube packed using "Green" color foam sheet. Passenger Side tube packed using "White" color foam sheet

No.	Parts Identification
1	Passenger / Right 'Rear' Bracket marked "PR"
2	Driver / Left 'Rear' Bracket marked "DR"
3	Passenger / Right 'Center' Bracket marked "PC"
4	Driver / Left 'Center' Bracket marked "DC"
5	Passenger / Right 'Front' Bracket marked "PF"
6	Driver / Left 'Front' Bracket marked "DF"

Note:

- This guide is to identify the parts and not a reference for part count.
- For part count, refer Parts List.
- Product / Bracket image is representative and actual design may vary.

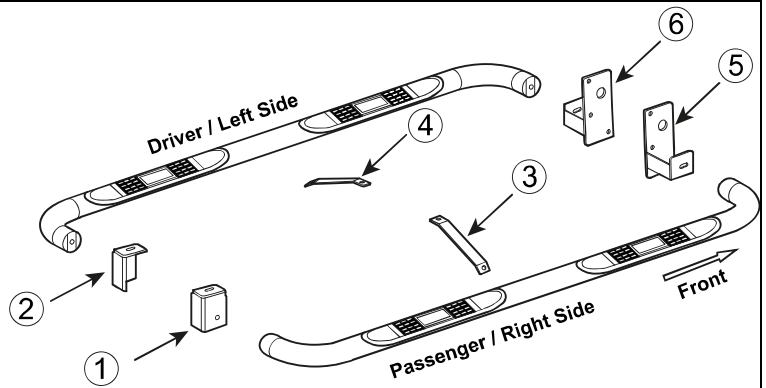

PRODUCT CARE

- Periodically check the product to ensure all fasteners are tight and components are intact.
- Regular waxing is recommended to protect the finish of the product.
- **Use ONLY Non-Abrasive automotive wax.** Use of any soap, polish or wax that contains an abrasive is detrimental and can scratch the finish leading to corrosion.
- Aluminum polish may be used to polish small scratches and scuffs for **Stainless Steel finish.**
- Mild soap may be used to clean the product for both **Stainless Steel and Black finish.**

FAQ's

1. Hardware's are not of correct size.

In GMC / Chevrolet truck model 2006 & up, customer needs to reuse the factory body bolts to install the bracket. If your vehicle is not GMC / Chevrolet 2006 & up, ensure that holes are not partially covered with any plastic grommet or rust? If it is, remove the plastic grommet & rust from the thread holes & re-try the installation.

2. Mounting Bracket are not getting Installed properly.

In some cases Illustration images shown in Installation manual may not be the exactly same as per actual vehicle images ,also if Driver / Passenger side mounting brackets are very identical in the design, suggest referring Parts Identification guide to avoid fitment issue.

3. Products are thumping / rattling after installation.

Ensure that all required mounting brackets / hardware's are installed & tighten correctly. Suggest using white lithium / regular grease between the metal to metal contact surfaces.

4. Side Bar is not aligning with vehicle / Step Pads are not aligning with vehicle doors.

Side bar may be interchanged or mounting brackets are not installed at the correct position in the vehicle. Refer Parts identification guide.

5. Missing / Excess Hardware.

Recheck hardware count as per the part list.

6. Product not installing properly.

Ensure make model year, cab length and bed size of your vehicle is listed in the application. All installation steps are followed correctly.

Check out these other TrailFX Products!!



Keystone Automotive Operations Inc. (KAO) warrants this product to be free of defects in material and workmanship at the time of purchase by the original retail consumer. KAO disclaims any other warranties, express or implied, including the warranty of fitness for a particular purpose or an intended use. If the product is found to be defective, KAO may replace or repair the product at our option, when the product is returned prepaid, with proof of purchase. Alteration to, improper installation, or misuse of this product voids the warranty. KAO's liability is limited to repair or replacement of products found to be defective, and specifically excludes liability for any incidental or consequential loss or damage.