



# FORD FLARESIDE & OTHER BEDLINER & TAILGATE



### Part No.

TG09X	TG10X	TG11X	TG25X	TG26X	TG29X	TG52X
TG99X						



Do not over tighten as screws can be stripped out.



30-60 min



CUTTING NOT  
REQUIRED



DRILLING  
REQUIRED



REMOVE CONTENTS FROM BOX. VERIFY ALL PARTS ARE PRESENT.



READ INSTRUCTIONS CAREFULLY BEFORE STARTING INSTALLATION.

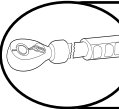

DO NOT OVER TORQUE. STANDARD OPERATING LOAD FOR TIGHTEN BODY MOUNT NUTS & BOLTS VARIES FROM **45** TO **65** FOOT POUND.

### Tools Required

Phillips Screwdriver	T30 Torx Head Driver
Drill with 3/8" Drill Bit	

### 1. INSTALLATION PROCEDURE:

#### WARNING:

- Do not transport a pickup truck facing backward with a liner installed.
- Air can get under the liner which may result in the liner coming out of the truck and causing damage or injury.

#### Truck Box Preparation:

- Clean truck box of all foreign matter and open any floor drains to ensure ventilation and moisture drainage.

#### NOTE:

- Bed liner can be installed by one person. However, using two people is recommended by the manufacturer.

### 2. Tailgate Cover Installation Steps

**NOTE: Your tailgate cover kit may have more or less hardware than shown.**

#### STEP 1

Remove 8 (eight) existing factory installed tailgate screws (Designated by "X" in FIGURE 1). Set aside for later use.

#### STEP 2

Center tailgate cover on truck tailgate. Line up predrilled holes in tailgate cover (See FIGURE 2) with the 8 holes in truck tailgate.

#### STEP 3

Place washers, supplied in kit, on the screws that were removed in Step 1 (See FIGURE 3) and fasten tailgate cover to the truck tailgate using appropriate driver.

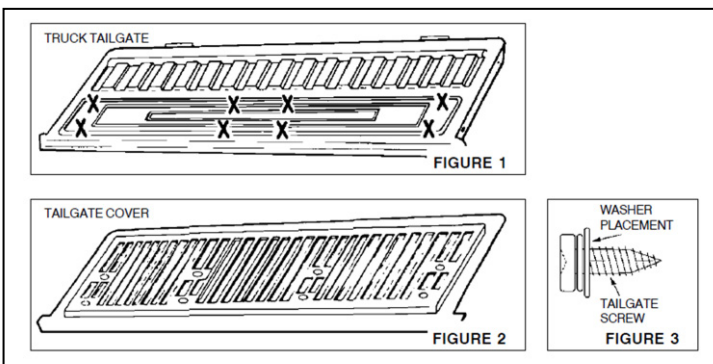

## 2a. Styleside Tailgate Cover Installation Steps

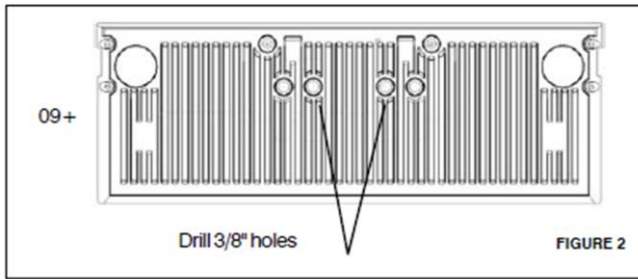
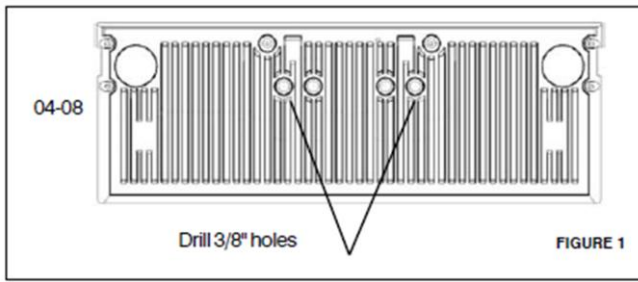

### STEP 1

Center tailgate cover on truck tailgate, locating any factory screws at predrilled hole locations. Remove these screws and set aside for later use.

### STEP 2

Drill two (2) outer holes (Figure 1) for 04-08 MY. Drill two (2) inner holes for 09+ MY. (Figure 2)

### STEP 3

Place washers on screws previously removed. Reinstall screws with washers and tighten down tailgate cover.

## 2B. Tailgate Cover Installation Steps - Nissan Titan

**NOTE: Your tailgate cover kit may have more or less hardware than shown.**

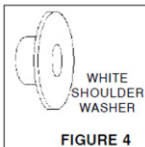
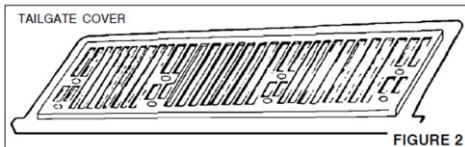
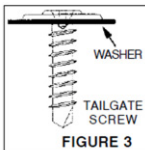
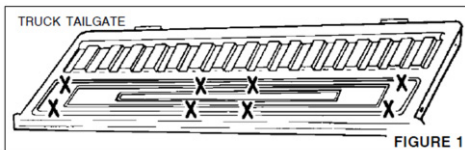

### STEP 1

Remove 8 (eight) existing factory installed tailgate screws (Designated by "X" in FIGURE 1). Set aside for later use.

### STEP 2

Place white shoulder washer, supplied in kit, in the sheet metal recess that the 4 tailgate screws closest to the tailgate rail cap were removed from in step 1. (See FIGURE 4)

### STEP 3

Place washers, supplied in kit, on the screws that were removed in Step 1 (See FIGURE 3) and fasten tailgate cover to the truck tailgate using appropriate driver.

## 2C. Tailgate Cover Installation Steps - Toyota Tundra D-Cab

**NOTE: Your tailgate cover kit may have more or less hardware than shown.**

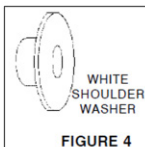
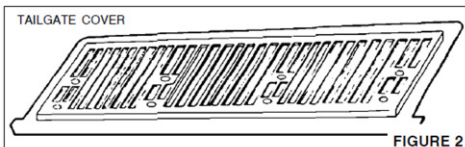
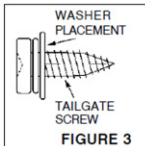
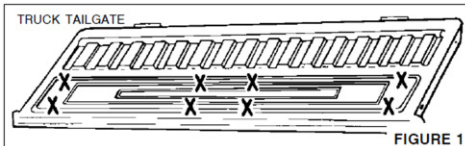

### STEP 1

Remove 8 (eight) existing factory installed tailgate screws (Designated by "X" in FIGURE 1). Set aside for later use.

### STEP 2

Place white shoulder washer, supplied in kit, into four outside slotted openings of plastic tailgate cover. (See FIGURE 4) Center tailgate cover on truck tailgate lining up predrilled holes in tailgate cover with the eight holes in truck tailgate.

### STEP 3

Place black washers, supplied in kit, on the screws that were removed in Step 1 (See FIGURE 3) and fasten tailgate cover to the truck tailgate using appropriate driver.

### 3. Under Rail Bedliner Installation Steps

(NOTE: Some bedliners may not have front rail lip.)

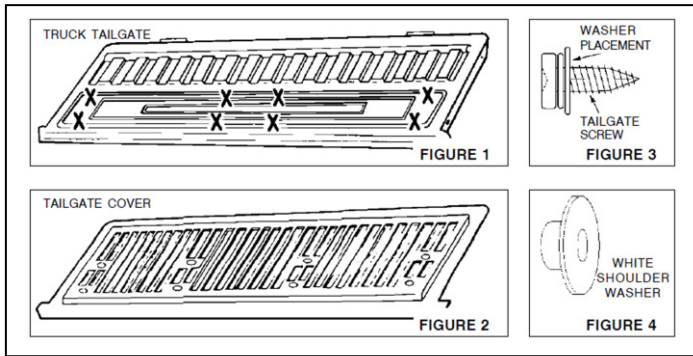

**CAUTION:** It is recommended that two (2) people install the bedliner to avoid damage to the painted surface of the truck.

#### STEP 1 (FIGURE 1)

Place bedliner in the truck bed, such that the front rail retainer fits over the front rail of the truck bed. While standing on the side of the truck, lift one side of the bedliner and slip the sidewall of the bedliner under the opposite wall of truck box.

#### STEP 2 (FIGURE 2)

While standing at the rear of the truck, lift the bedliner floor in the center. (FIGURE 2) This procedure allows the bedliner sidewall to rotate away from the bed rail. Have a 2nd person slip/lock the bedliner sidewall in position by applying a downward force. **NOTE:** Make sure that the raised liner locking tabs on the sidewalls are secured behind and under the side rail sheet metal of the truck box.

**(NOTE The bedliner has been designed to allow for expansion/contraction in extreme ambient temperatures. Therefore it is impossible to have a perfect fit at all times.)**

#### STEP 3

Check the overall fit. It is important that the bedliner fits securely in place under the bed rails. If necessary, repeat steps 2 & 3.

### 4. Bedliner Installation Steps - Ford Flareside 1992-1996 Only

**NOTE:** Installation is easiest if bedliner is at "room temperature" or about 70 degrees F.

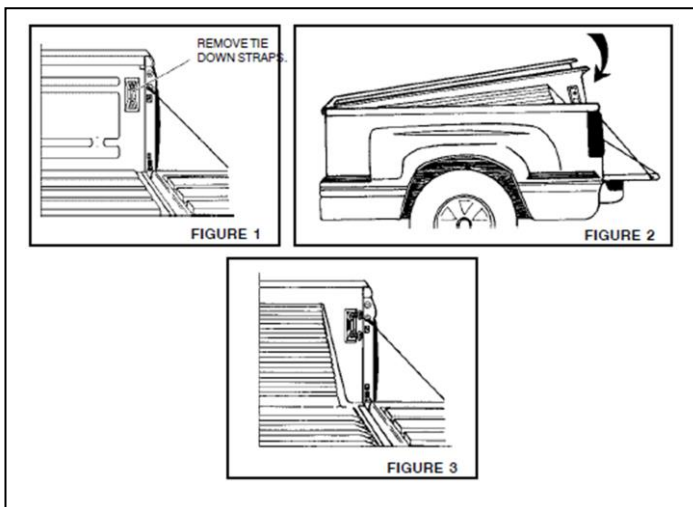

#### STEP 1

Remove the two cargo tie down straps located on the left and right side walls of the truck box. Save the parts for re-installation. (see FIGURE 1).

#### STEP 2

**RECOMMEND THE USE OF 2 PEOPLE FOR THIS STEP.**

Place the bedliner in truck box. While standing beside the truck box, lift the rear (tailgate end) of the bedliner upward about 30-degrees and push down on the front rail until the bedliner snaps onto the truck box. (NOTE: Lifting too high will cause difficulty in snapping the liner onto the truck box). Lower the rear of the bedliner (see FIGURE 2).

#### STEP 3

Using the cargo tie down straps and screws removed in STEP 1, fasten the rear sidewalls of the bedliner by lining up the pre-drilled holes in the bedliner with the holes in the truck box and the holes in the tie down strap. Place the screws through the holes and tighten securely (see FIGURE 3).

## **PRODUCT CARE**

- Sweep any dirt and debris out of the bed of the truck. Pick up any items that may scratch the liner, such as rocks or large sticks.
- Inspect Bed liner on frequent basis to identify any damages.
- Clean the product with mild soap / cleaner to remove stains.
- While washing Rinse bed and tailgate thoroughly until no soap runs off the truck.

## **FAQ's**

1. **Will the bed feel hotter than the rest of the truck?**  
*No, protective coating shall help to keep it cooler than truck.*
2. **Protective coating is used as an undercoating?**  
*Yes, it can be used.*
3. **Is protective coating environmentally friendly?**  
*Yes, there is no possible health hazard and it is environment friendly*
4. **Can I take it out Protective Coating?**  
*No, Protective coating is a permanent coating and can't be removed.*
5. **Does the lining require special maintenance?**  
*No, it can be cleaned up with mild soap.*
6. **Missing / Excess Hardware.**  
*Recheck hardware count as per the part list.*
7. **Product not installing properly.**  
*Ensure make model year, cab length and bed size of your vehicle is listed in the application. All installation steps are followed correctly.*