



TYGER[®]

TYGER HITCH™

BEFORE INSTALLATION

READ INSTRUCTIONS CAREFULLY BEFORE STARTING INSTALLATION. REMOVE CONTENTS FROM BOX AND VERIFY ALL PARTS ARE PRESENT. ASSISTANCE IS RECOMMENDED. FAILURE TO IDENTIFY DAMAGE BEFORE INSTALLATION COULD LEAD TO A REJECTION OF ANY CLAIM. IF ANY DAMAGE FOUND, PLEASE TAKE A PICTURE FOR THE CLAIM PURPOSE.

WARNING

TO PROTECT YOUR INVESTMENT, WAX THIS PRODUCT AFTER INSTALLING. REGULAR WAXING IS RECOMMENDED TO ADD A PROTECTIVE LAYER OVER THE FINISH. DO NOT USE ANY TYPE OF POLISH OR WAX THAT MAY CONTAIN ABRA-SIVES THAT COULD DAMAGE THE FINISH. USE ONLY MILD SOAP TO CLEAN THE SIDE ARMOR.

TG-HC2J003B

Parts List

- x1 Receiver Towing Hitch
- x1 Trailer Wiring Harness Bracket
- x4 12-1.75mm x 120mm Hex Bolts
- x6 12mm x 32mm x 3mm Flat Washers
- x2 12mm Lock Washers
- x2 12-1.75mm Nylon Lock Nuts

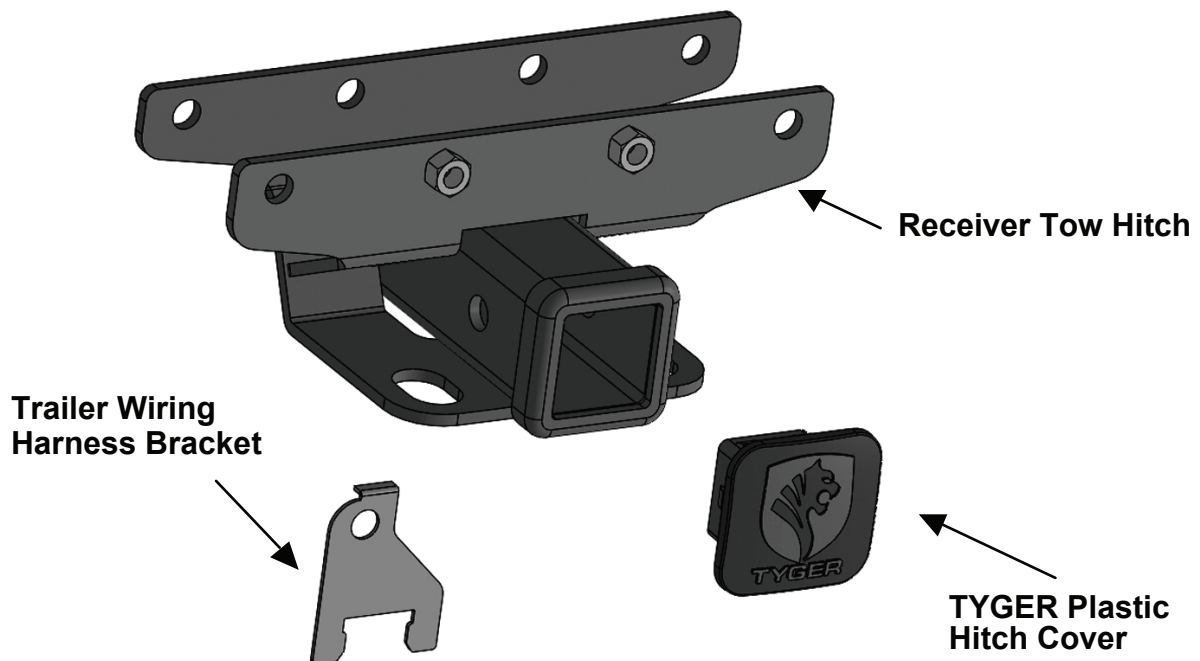



STEP 1

Locate the frame crossmember behind the rear bumper, (Fig 1). Determine if the bumper is equipped with an L-shaped bumper support bracket connecting the bottom of the bumper to the back of the crossmember, (Figs 1-2).

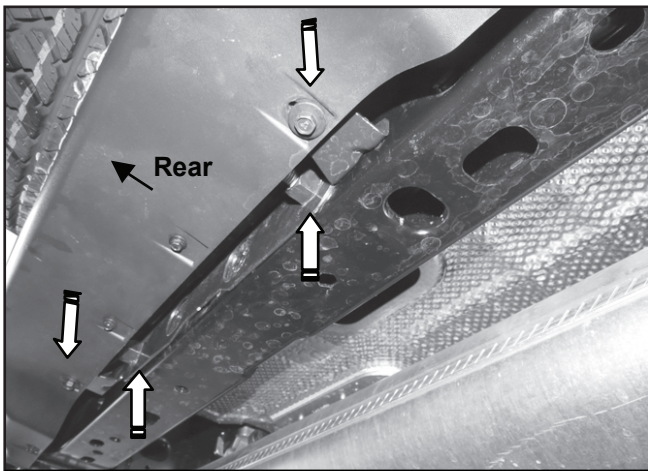

(Fig 1) Remove the hardware (arrows) attaching the L-support bracket, (if equipped), to the bottom of the bumper and to the crossmember

NOTE: Must reuse (2) 12mm fine thread factory hex bolts to attach L-support bracket to outer holes (arrows) on Hitch



(Fig 2) L-bumper support bracket

Models equipped with an L-shaped support bracket:

a. Remove the factory bolts attaching the support bracket to the crossmember and bottom of bumper, (Fig 1). Next, loosen but do not remove the (4) factory bumper bolts, (Fig 3).

b. Select the Receiver Hitch. Hold the Receiver Hitch up to and over the crossmember. Insert the Hitch between the crossmember and the support bracket.

NOTE: The inner welded nuts on the Hitch will be facing the rear.

c. Slide the mounting tab for the Trailer Connection Bracket between the driver/left outer mounting hole on the Hitch and the L-support bracket, (Figs 4-5).

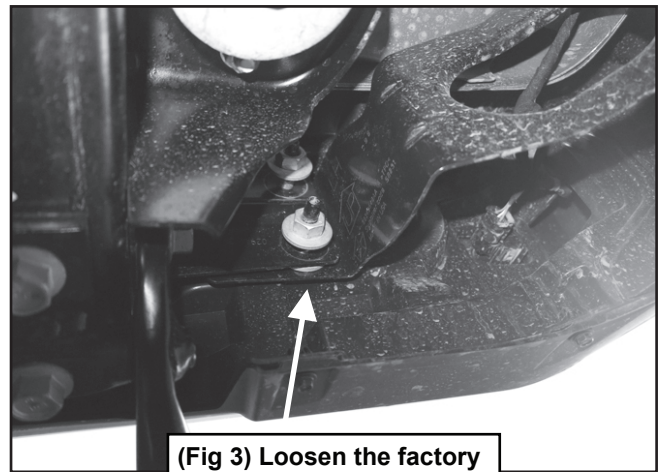

(Fig 3) Loosen the factory bumper bolts, (2 per side)

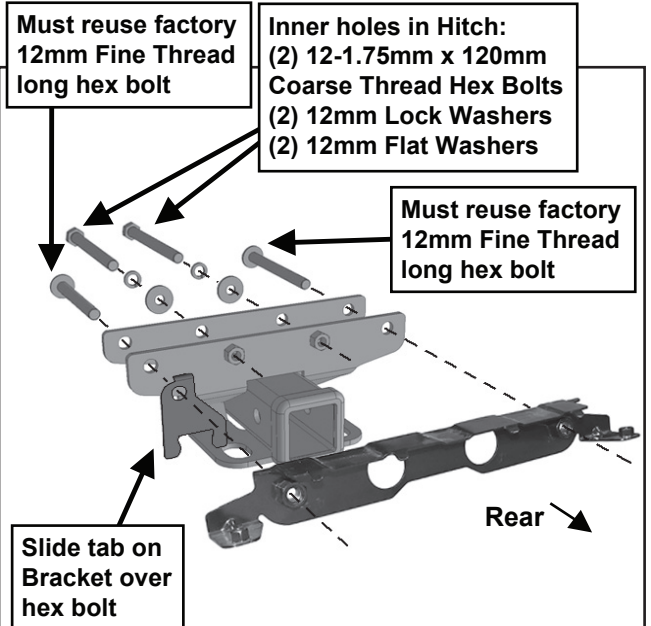

(Fig 4) Receiver Towing Hitch assembly with factory L support bracket and Trailer Harness Bracket



d. Insert the included (2) 12-1.75mm x 120mm Coarse Thread Hex Bolts, (2) 12mm Lock Washers and (2) 12mm Flat Washers through the (2) inner mounting holes in the Hitch, through the frame and into the welded nuts on the Hitch, (Figs 3-4). Do not tighten hardware.

e. Line up the factory L-support bracket over the weld nuts on the Receiver Hitch, (Fig 4).

f. Select (2) factory "fine thread" hex bolts for reuse. Insert the (2) factory long bolts through the outer holes in the Hitch, through the crossmember and into the welded nuts on the L-support bracket, (Figs 4-5).

IMPORTANT: Only use the long factory fine thread hex bolts to attach the L-support bracket to the back of the Hitch. **DO NOT USE** the included 12-1.75mm x 120mm Coarse Thread Hex Bolts or damage to the L-support bracket may result.

NOTE: All Bolts will face towards the rear end of the vehicle. Do not tighten hardware at this time.

g. Reattach the bottom of the bumper to the factory L-support bracket. Adjust the bumper and fully tighten all hardware

Models without L-shaped Bracket:

a. Loosen but do not remove the (4) factory bumper bolts, (Fig 3).

b. Hold the Receiver Hitch up to the crossmember. On some model-years, there may be (2) factory hex bolts and (1) double nut plate attached to the crossmember, (Figs 6-7). Remove the hex bolts and double nut plate, this hardware will not be reused.

c. Line up the holes in the Hitch with the crossmember.

NOTE: The inner welded nuts on the Hitch will be facing the rear.

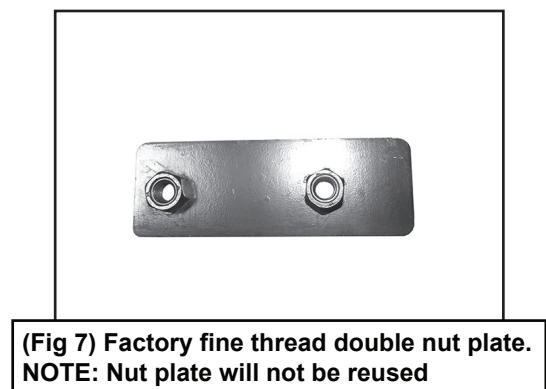
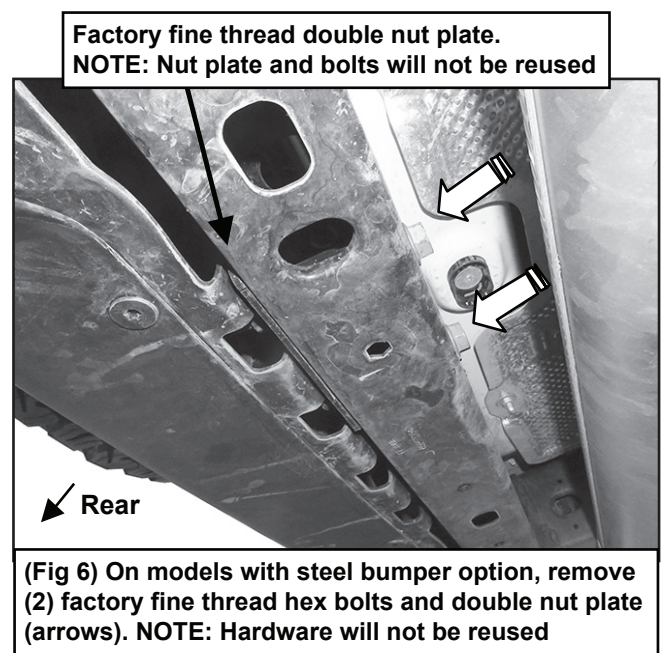
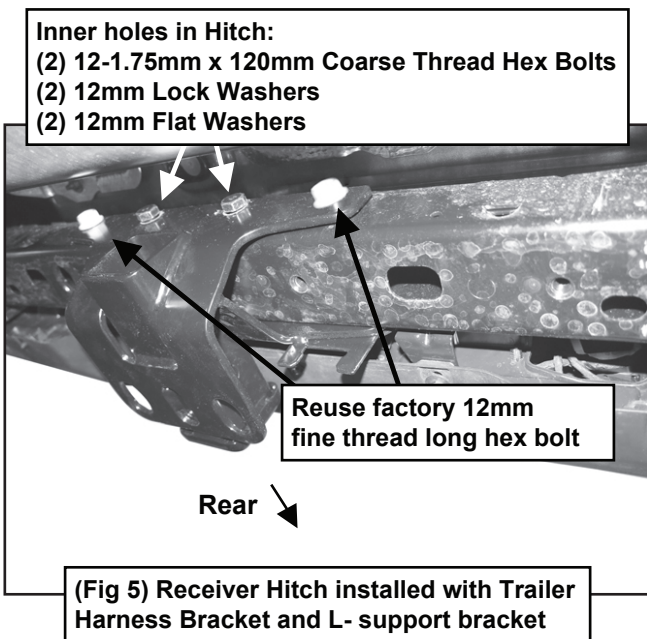



TYGER[®]

d. Insert the included (2) 12-1.75mm x 120mm Coarse Thread Hex Bolts, (2) 12mm Lock Washers and (2) 12mm Flat Washers through the (2) inner mounting holes in the Hitch, the cross-member and into the welded nuts on the Hitch, (Figs 8-9). DO NOT reuse the factory 12mm fine thread long hex bolts, if equipped. Snug but do not tighten hardware at this time.

e. Next, insert (2) 12-1.75mm x 120mm Coarse Thread Hex Bolts and (2) 12mm Flat Washers through the outer holes in the Hitch, through the crossmember and out through the Hitch, (Figs 7-8).

f. If installing the Trailer Connection Tab, slide the Tab over the end of the driver/left outer Hex Bolt, (Figs 7-9).

g. Secure the (2) outer 12-1.75mm Coarse Thread Hex Bolts to the Hitch with (2) 12mm Flat Washers and (2) 12mm Nylon Lock Nuts, (Figs 7-9).

h. Center and adjust the Receiver Hitch and fully tighten all hardware.

STEP 2

Attach the trailer harness to the Trailer Connection Tab, if installed.

STEP 3

Do periodic inspections of the installation to make sure that all hardware is secure and tight.

