



TYGER®

TYGER RIDER®

TG-SS2D35318

BEFORE INSTALLATION

READ INSTRUCTIONS CAREFULLY BEFORE STARTING INSTALLATION. REMOVE CONTENTS FROM BOX AND VERIFY ALL PARTS ARE PRESENT. FAILURE TO IDENTIFY DAMAGE BEFORE INSTALLATION COULD LEAD TO A REJECTION OF ANY CLAIM.

TORQUE VALUES

Fastener Size	Class 8.8 Torque (ft-lbs)	Class 10.9 Torque (ft-lbs)
6mm	6-7	6-7
8mm	15-16	22-23
10mm	31-32	44-45
12mm	54-55	78-79
14mm	87-88	125-126

Parts List

- x1** Driver/Left Sidebar
- x1** Passenger/Right Sidebar
- x1** Driver/left Front Mounting Bracket Only
- x1** Passenger/right Front Mounting Bracket Only
- x2** Driver/left Center and Rear Mounting Brackets
- x2** Passenger/right Center and Rear Mounting Brackets
- x3** Right Bend Support Brackets (drv front, pass cntr and rear)
- x3** Left Bend Support Brackets (pass front, driver cntr and rear)
- x6** 8mm Nut/Bolt Plates
- x6** 8mm Plastic Retainers
- x12** 8-1.25mm x 25mm Combination Hex Bolts
- x18** 8-1.25mm x 30mm Hex Bolts
- x24** 8mm x 24mm x 2mm Flat Washers
- x12** 8mm Lock Washers
- x6** 8mm Hex Nuts
- x6** 8mm Nylon Lock Nuts
- x12** 6mm x 25mm Hex Bolts
- x24** 6mm x 22mm x 2mm Flat Washers
- x12** 6mm Nylon Lock Nuts

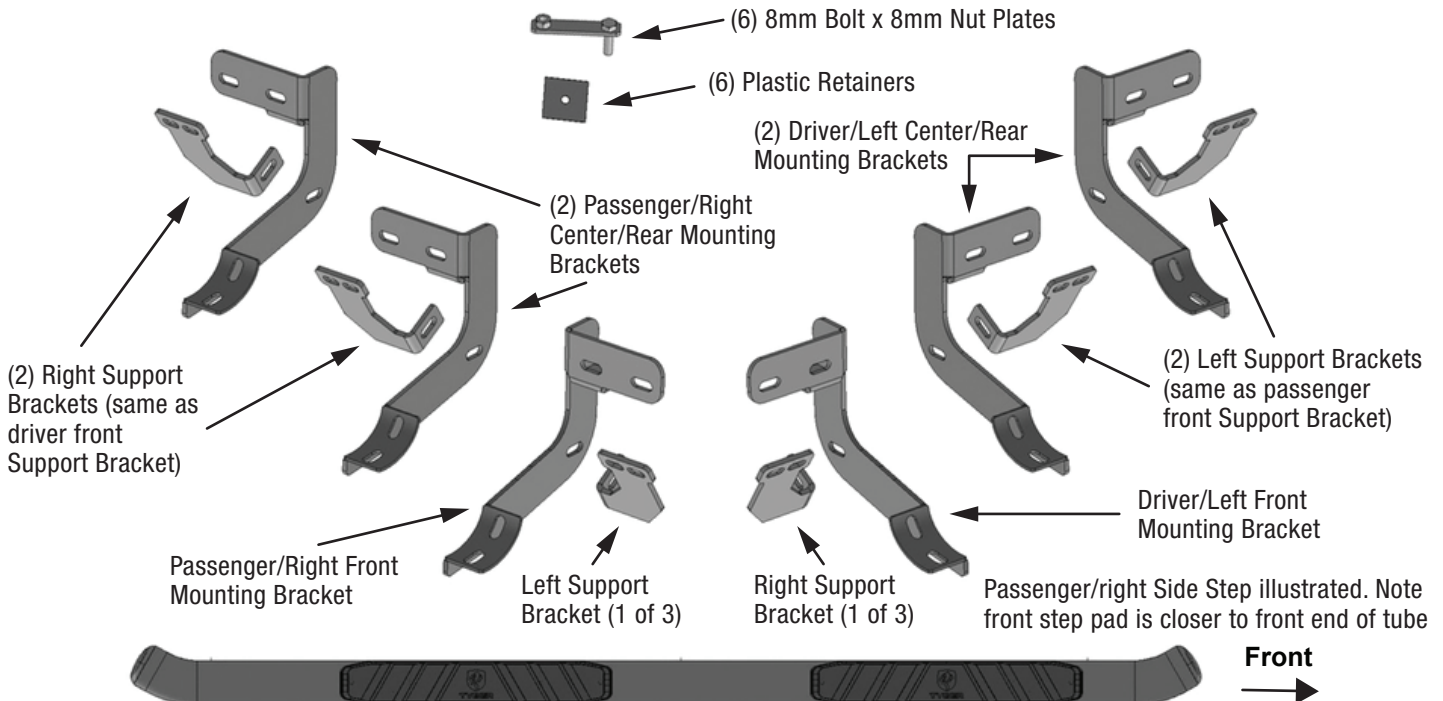



TYGER[®]

STEP 1

REMOVE CONTENTS FROM BOX. VERIFY ALL PARTS ARE PRESENT. READ INSTRUCTIONS CAREFULLY BEFORE STARTING INSTALLATION. DRILLING MAY BE REQUIRED.

STEP 2

Starting at the passenger/right side of the vehicle, remove the sealing tape covering the factory holes in the side of the inner panel, (Figure 1).

Passenger Side Installation Pictured

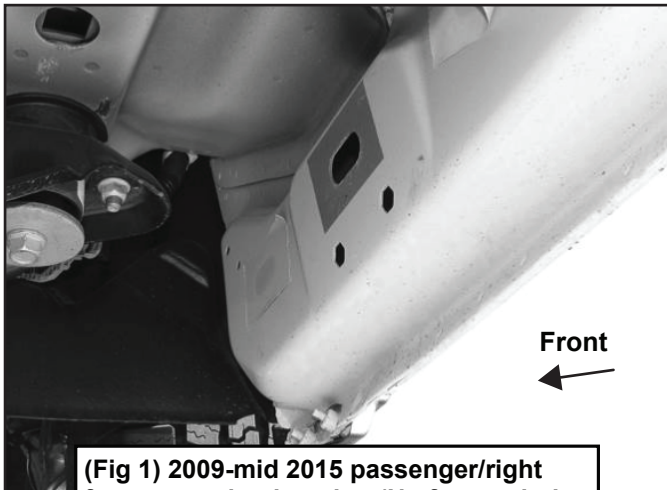

(Fig 1) 2009-mid 2015 passenger/right front mounting location (No factory holes in pinch weld 2009-2012 models)

STEP 3

Determine the correct procedure to attach the passenger/right front Mounting Bracket for your model/year:

Models without factory threaded inserts in body panel:

a. Partially thread an 8mm Hex Bolt into the threaded end of an 8mm Bolt and Nut Plate, (Figure 2). Thread the Hex Bolt in until it is flush with the welded nut, (Figure 3). Use the Hex Bolt as a handle and insert the Bolt and Nut Plate into the oval hole, (Figure 4).

Passenger Side Installation Pictured



(Fig 2) 8mm Bolt-8mm Nut Plate, NOTE: 8mm Bolt-Nut Plate is not required on models with threaded inserts

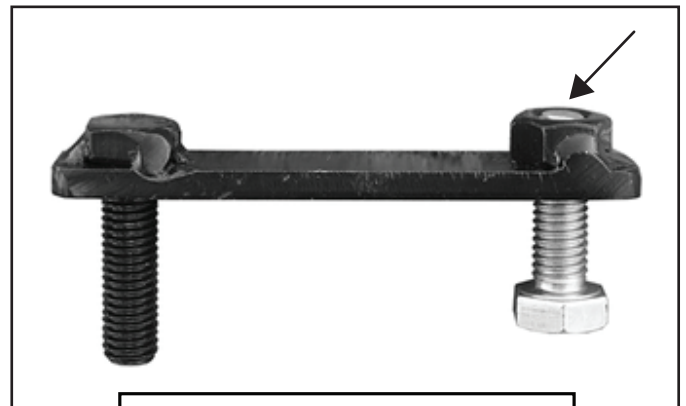

(Fig 3) Thread (1) 8mm Hex Bolt into the nut on the plate. Stop when bolt reaches end of nut as pictured

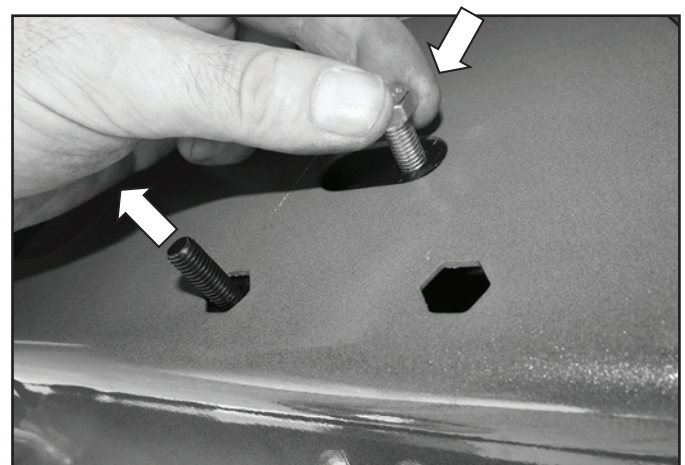

(Fig 4) Use the loose Hex Bolt as a handle. Insert the Bolt Plate into the oval hole and feed the threaded end out either factory hex shaped hole. **IMPORTANT:** Do not let go of the hex bolt until after Plastic Retainer has been threaded onto bolt (Fig 5)



TYGER®

b. Feed the threaded bolt on the Bolt Plate through one of the hex shaped factory holes, (Figure 4).

c. Thread (1) 8mm Plastic Retainer onto the threaded end and down tight against the body panel, (Figure 5).

NOTE: The Plastic Retainer is designed to keep the Bolt/Nut Plate from falling into the body panel and to aid in Bracket installation.

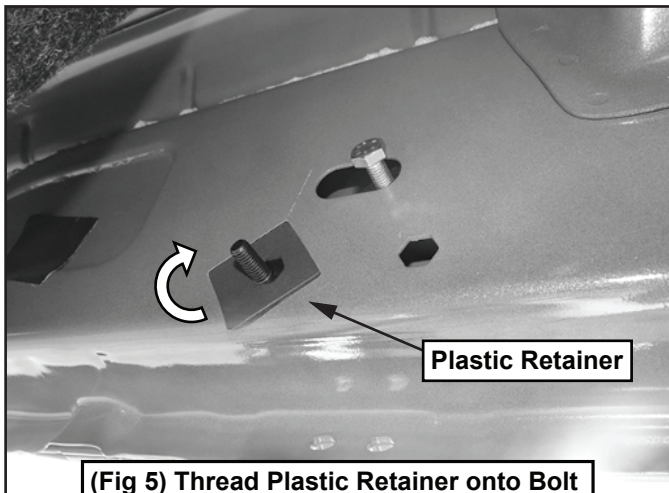

(Fig 5) Thread Plastic Retainer onto Bolt Plate to hold Bolt Plate in position.

d. Select the passenger/right front Mounting Bracket, (Figure 6). Attach the Bracket to the threaded end of the Bolt Plate with (1) 8mm Flat Washer, (1) 8mm Lock Washer and (1) 8mm Hex Nut, (Figure 7). DO NOT tighten at this time.

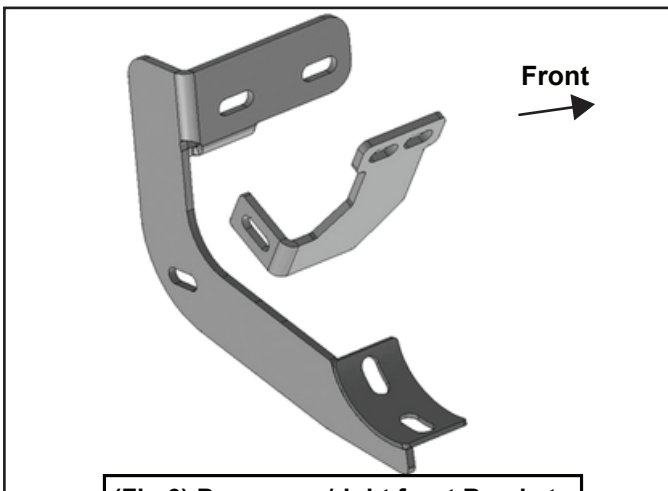

(Fig 6) Passenger/right front Brackets

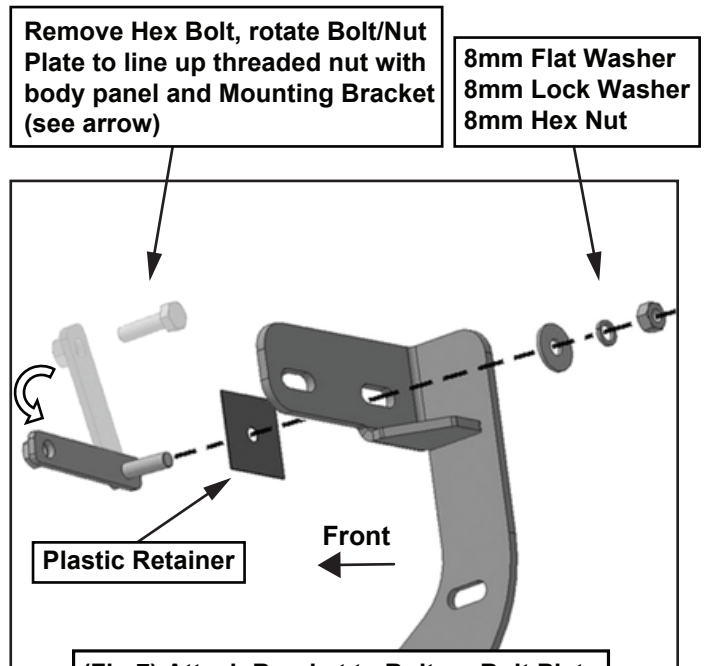

(Fig 7) Attach Bracket to Bolt on Bolt Plate

e. Remove the 8mm Hex Bolt from the nut on the Bolt Plate from Step 3a, (Figure 3). Rotate the Bolt on the Bolt Plate until the threaded nut lines up with the remaining hole in the Mounting Bracket and body panel, (Figures 7 & 8). Attach the Bracket to the threaded Nut Plate with (1) 8mm x 30mm Hex Bolt, (1) 8mm Lock Washer and (1) 8mm Flat Washer, (Figure 8). DO NOT fully tighten hardware at this time.

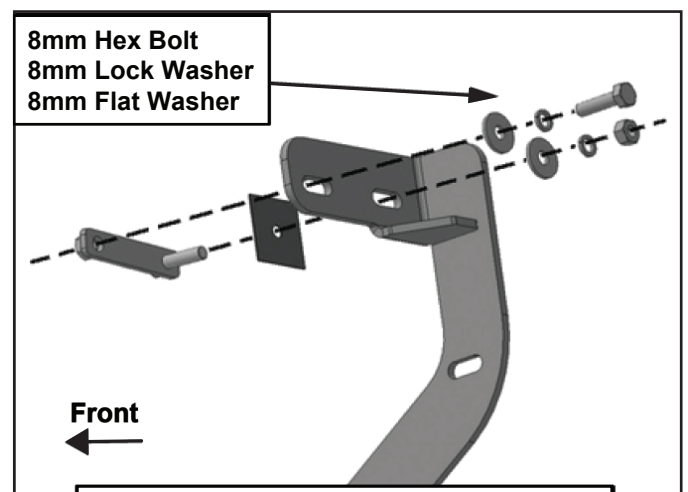

(Fig 8) Remove 8mm Hex Bolt (see Fig 3). Rotate Bolt Plate to line up with remaining factory hex shaped hole.



TYGER®

Models with factory threaded inserts:

a. Attach the passenger/right Front Mounting Bracket directly to the threaded inserts with (2) 8mm x 30mm Hex Bolts, (2) 8mm Lock Washers and (2) 8mm Flat Washers, (Figures 9 & 10). Leave hardware loose

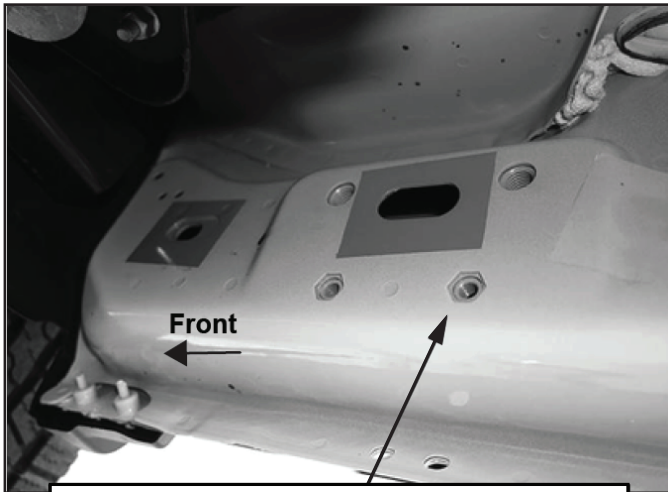

(Fig 9) Passenger side front mid 2015-on, models with factory installed threaded inserts

(2) 8mm Hex Bolts
(2) 8mm Lock Washers
(2) 8mm Flat Washers

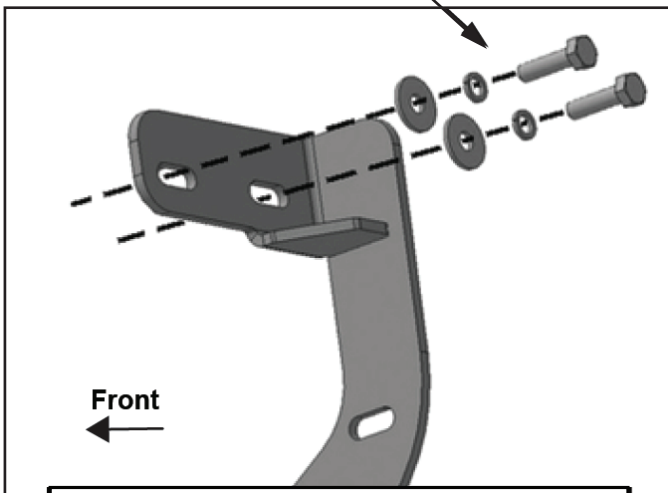

(Fig 10) Models with factory installed threaded inserts. Note Bolt Plate not required

STEP 4

Next, select the passenger/right front Support Bracket, (Figures 6 & 11).

NOTE: Passenger front Support Bracket is the same as driver/left center and rear Support Brackets. Attach the Support Bracket to the front of the front Bracket with (1) 8mm x 30mm Hex Bolt, (2) 8mm Flat Washers and (1) 8mm Nylon Lock Nut, (Figure 11).

Passenger Side Installation Pictured

8mm Hex Bolt
(2) 8mm Flat Washers
8mm Nylon Lock Nut

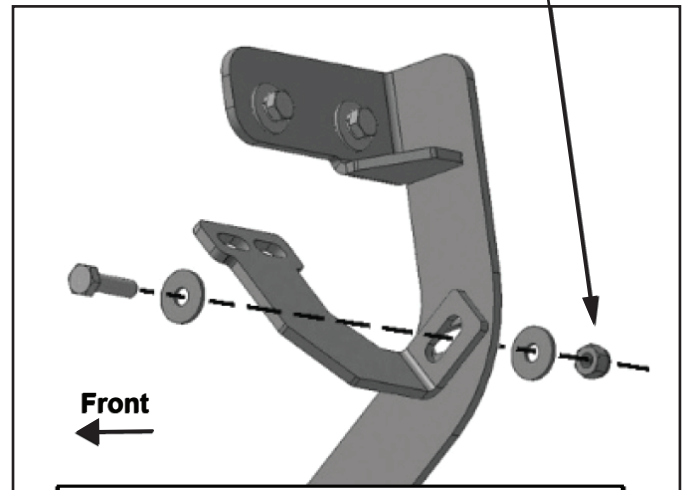

(Fig 11) Attach passenger/right front Support Bracket to front of Mounting Bracket

STEP 5

Rotate the Support Bracket to the back of the pinch weld. Line up the slots in the top of the Support Bracket with the (2) factory holes in the pinch weld. Attach the Bracket to the back of the pinch weld with (2) 6mm x 25mm Hex Bolts, (4) 6mm Flat Washers and (2) 6mm Nylon Lock Nuts, (Figure 12). DO NOT fully tighten hardware at this time.

IMPORTANT: 2009-12 models may not be equipped with factory holes and will require drilling through the pinch weld to attach the Support Bracket. DO NOT drill through pinch weld at this time, (see STEP 9).



TYGER[®]

- (2) 6mm Hex Bolts
- (4) 6mm Flat Washers
- (2) 6mm Nylon Lock Nuts

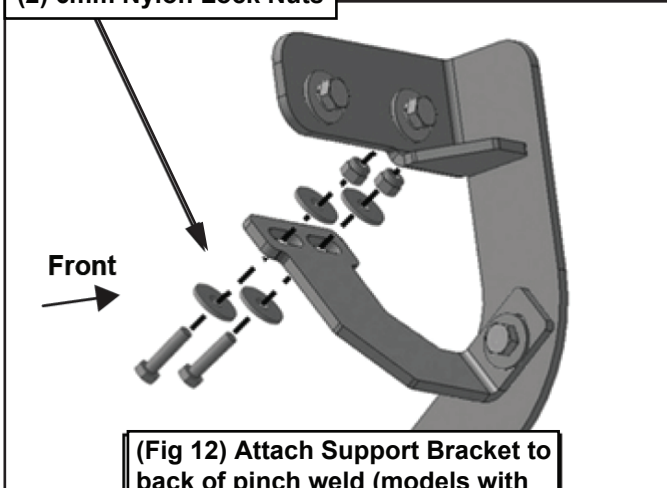

(Fig 12) Attach Support Bracket to back of pinch weld (models with factory holes in pinch weld only)

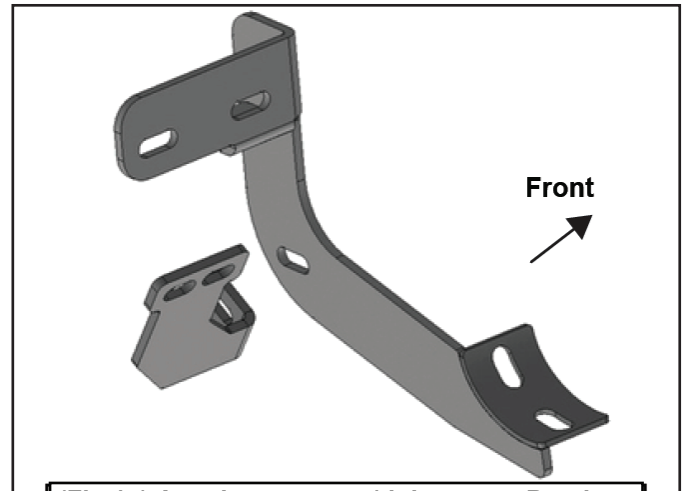

(Fig 14) Attach passenger/right center Brackets



(Fig 15) Passenger/right center Brackets installed

STEP 6

Move along the side of the body panel to the center mounting location, (Figure 13). Select the passenger/right center Mounting Bracket and Support Bracket, (Figure 14). Repeat **STEPS 2—4** to install the passenger/right center Bracket and Support Bracket, (Figures 14 & 15).

NOTE: The Center and Rear Mounting Brackets and Support Brackets are the same.

Passenger Side Installation Pictured

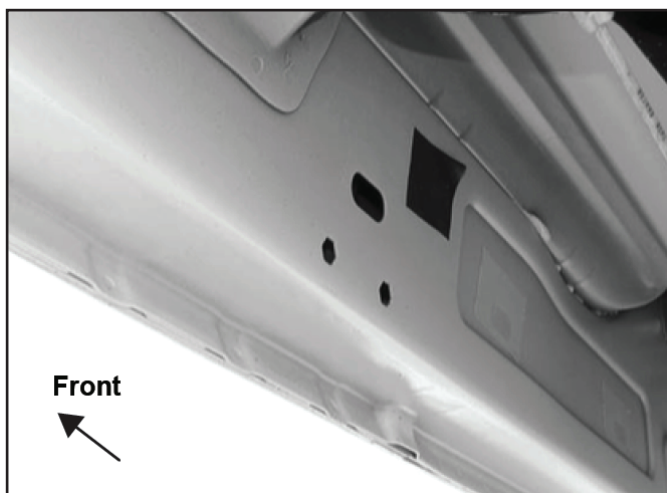

(Fig 13) Passenger/right center location

STEP 7

Move to the rear location, (Figure 16). Repeat **STEP 5** to install the rear Brackets, (Figure 17).

NOTE: The cradles on the front, center and rear Brackets must all face forward.



TYGER®

Passenger Side Installation Pictured

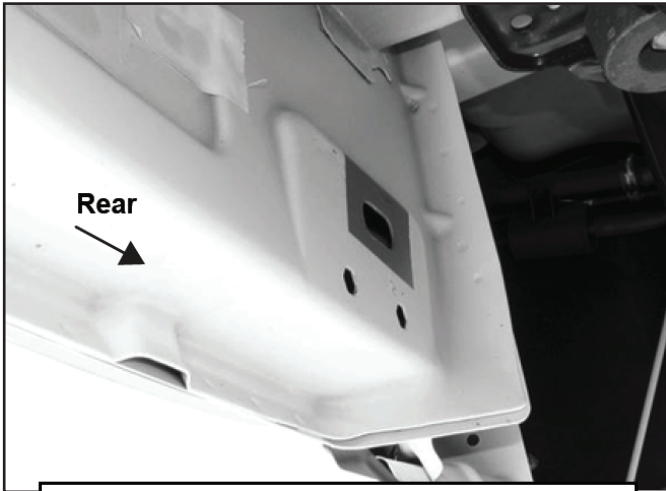

(Fig 16) Passenger/right rear mounting location



(Fig 17) Passenger/right rear Brackets installed

Passenger Side Installation Pictured

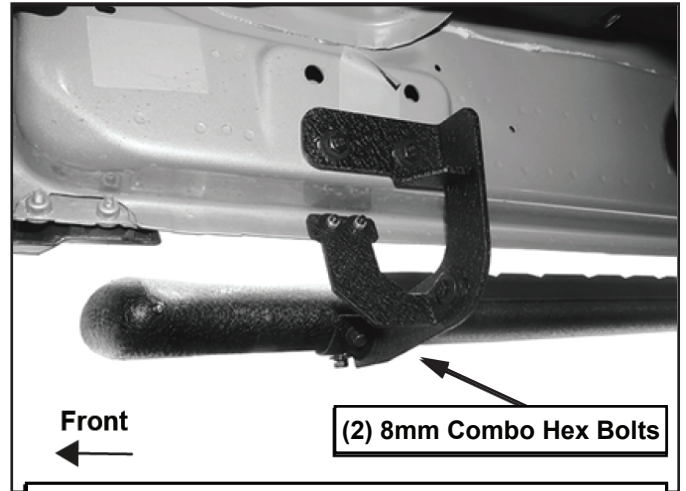

(Fig 18) Passenger/right front complete installation

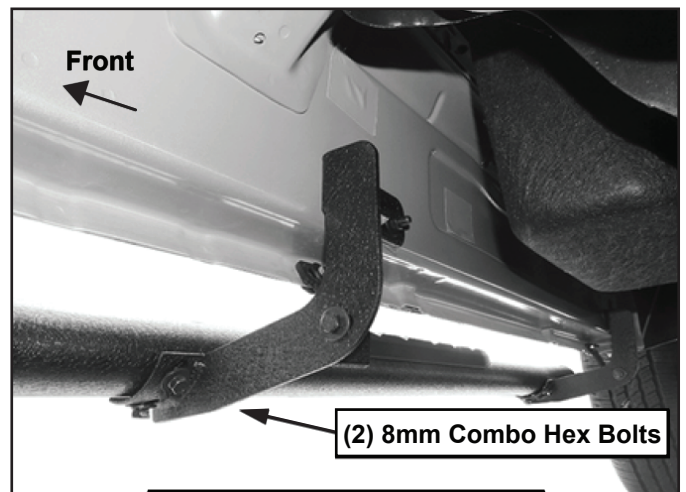

(Fig 19) Passenger/right center and rear Sidebar installation

STEP 8

Select the passenger/right Sidebar. Carefully position the Sidebar onto the (3) Mounting Brackets.

IMPORTANT: DO NOT slide, (front to back or rotate), the Sidebar on the Brackets or damage to the finish on the Sidebar may result. Attach the Sidebar to the (3) Brackets with (6) 8mm Combination Hex Bolts, (Figures 18 & 19). DO NOT fully tighten at this time

STEP 9

Properly level and adjust the Sidebar and fully tighten all hardware.

2009-12 models requiring drilling for Support Brackets:

- Make sure the Sidebar is level to the vehicle. Adjust and tighten all mounting hardware.
- Line up the slots on the Support Brackets with the back of the pinch weld. Mark the location of the slots onto the pinch weld.



TYGER®

c. Drill (2) 1/4" holes through the pinch weld for each Support Bracket.

IMPORTANT: DO NOT drill too close to the bottom edge of the pinch weld. Adjust the Support Brackets as necessary to move the slots up the body panel away from the edge. Drill the holes toward the outside of the marked slots.

d. Attach each Support Bracket to the pinch weld with (2) 6mm Hex Bolts, (4) 6mm Flat Washers and (2) 6mm Nylon Lock Nuts, (Figures 18 & 19). Check the Sidebar for level then fully tighten all hardware.

Passenger Side Installation Pictured



Installation Complete

STEP 10

Move to the driver/left side of the vehicle. Repeat **STEPS 1—9** for driver/left Sidebar installation.

STEP 11

Do periodic inspections to the installation to make sure that all hardware is secure and tight.