

LED BEACON

OPERATION

RED: To +VDC

BLACK: To Chassis Ground (-)

FLASH PATTERN SELECTION

1. Open

Twist the dome lens counter clockwise ①, then lift the dome lens to open.

2. Change

Momentarily push the red button to change to the next flash pattern. (see Flash Patterns Chart)

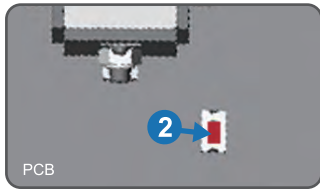

3. Close

Align dome indent **A** with base **B**, then twist clockwise **C** to close.

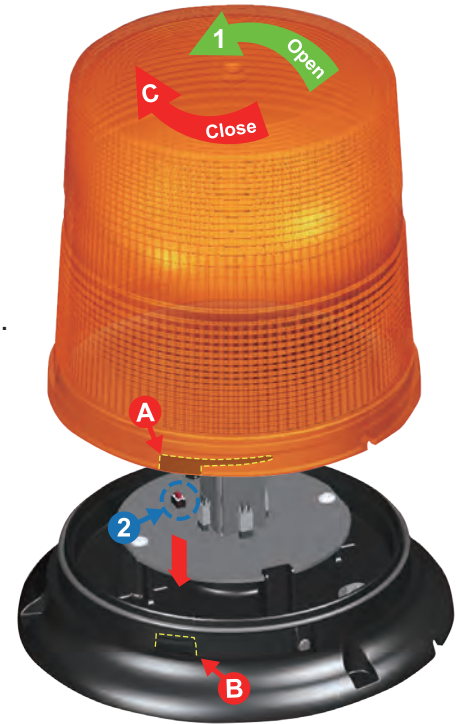

FLASH PATTERNS

1	8 Flash	4	Triple
2	Single	5	Quad
3	Double		

NOTE: This unit may not be factory-set at FP#1

WARNING:

It is not recommended to use magnetically mounted warning devices on outside of vehicle in motion. Usage is at the sole risk and responsibility of the user.

3 Bolt Mount

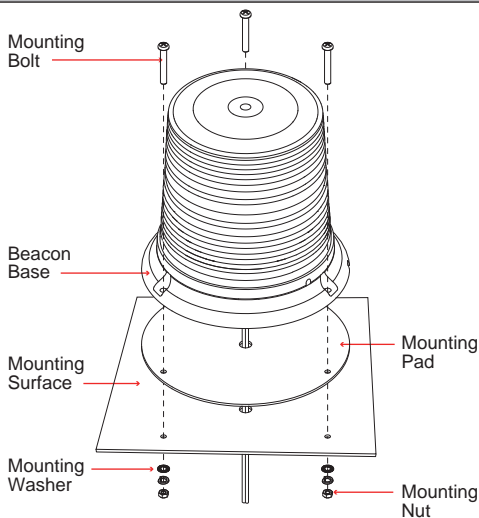

1. Drill holes on the mounting surface for the wire-exit and mounting bolts.
2. Secure the beacon onto the mounting surface with mounting bolts.

1" Pipe Mount

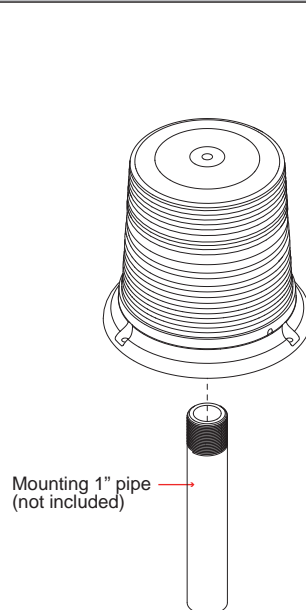

Magnetic Mount

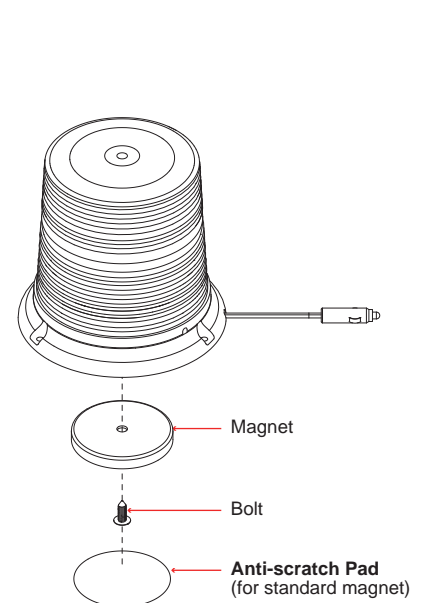

NOTE: All diagrams may not show in scale.

Find more United Pacific products on our website.

Learn more about emergency and warning lighting we have.