



## ÜRO Parts Collapsible BMW Coolant Transfer Pipe

**Part# 11 14 1 439 975-PRM**

Design Revision – Eliminated rear spacer piece and changed front seal

Late model BMW V8 models fitted with the N62 engine can suffer from a failure of the front seal of the water transfer feed pipe located under the intake valley pan gasket.

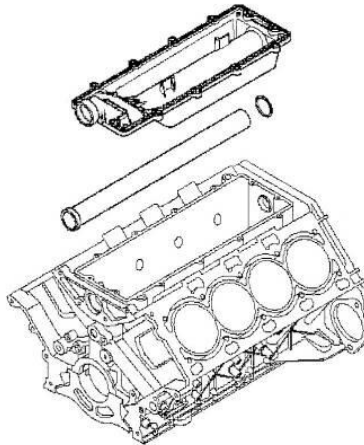

The original bonded seal fails primarily due to corrosion caused by an electro chemical reaction between the materials over time.



Symptoms will be a coolant leak coming from the 5mm weep hole in the front timing cover of the engine and eventual loss of coolant and over-heating.

The factory design is a long tube which can only be fitted from the front of the engine with the timing cover removed; a job that can cost upwards and take over 20 hours of shop time.

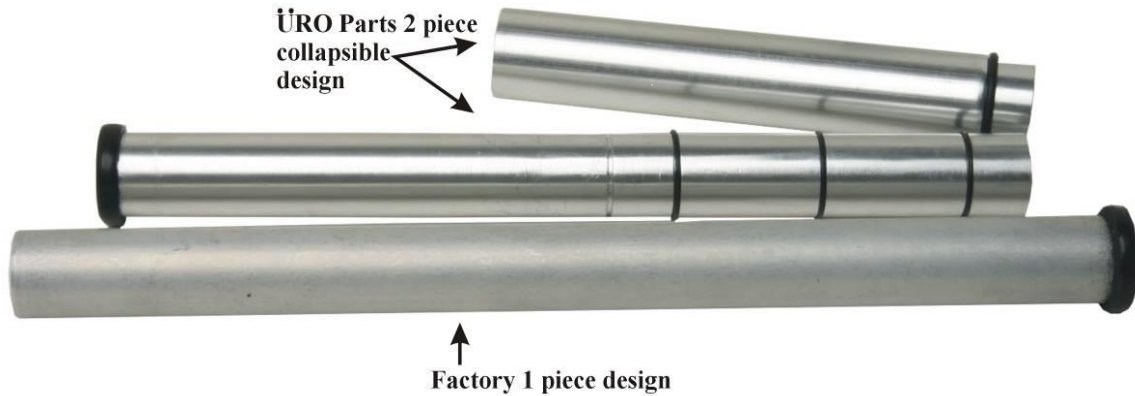

The URO Parts designed water pipe collapses allowing the same repair to be completed without removing the timing cover, saving thousands in labor costs and many hours of down time.



**BMW Water Tube Kit Contents:**

<u>Item Description</u>	<u>Supplied</u>
#1 Front Inner Water Tube	(qty 1)
#2 Rear Outer Water Tube	(qty 1)
#3 Rear Packing Shims 0.020" (aluminum)	(qty 3)
#4 Inner Tube O-Ring Seals	(qty 3)
#5 Rubber Grease Packet	(qty 1)
#6 Spirolux Locking Ring	(qty 1)
#7 Front Tube Seal	(qty 1)
#8 Rear Tube O-Ring Seal	(qty 1)

Additional BMW Factory Parts Recommended:

\*(This is a list of other items that will be required for completion of the water tube installation)

Qty 1 11 14 7 507 278 intake valley pan / gasket

Qty 2 11 61 7 521 181 intake manifold gasket

Qty 1 11 51 7 508 535 water pump gasket

Qty 1 11 51 7 507 717 water pump o-ring

Qty 1 11 51 1 439 976 water return pipe

\*Note: other miscellaneous parts may require replacing based on the tear down necessary to access water pipe. See factory workshop manual for suggested parts listing.

The following is a guideline for installation of the kit and illustrations showing the basic steps. A trained technician following the factory workshop manual and repair procedures is necessary to properly complete this repair.

Note: All images have been completed on a stripped engine block for the purpose of making the photos clearer; this is not required for the repair.

1. After draining the cooling system, remove the intake manifold and other related components to expose the intake valley pan.

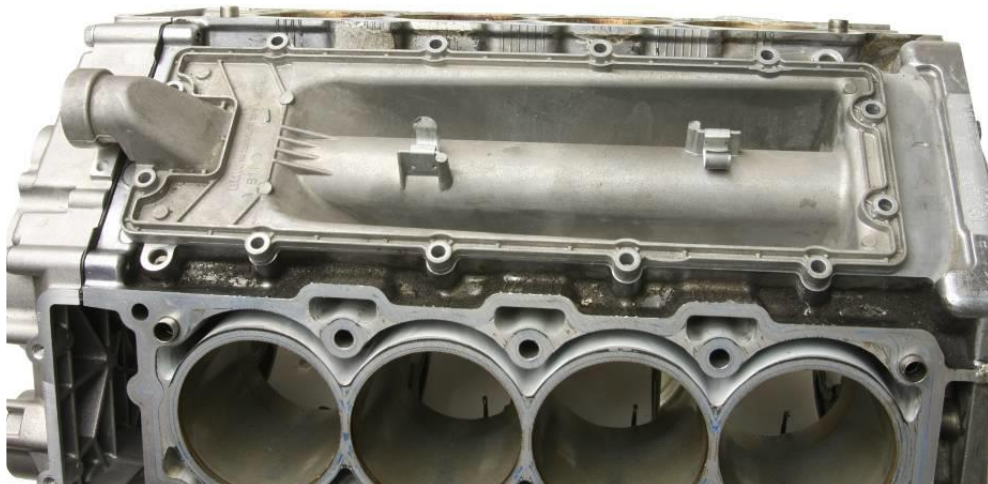

2. Remove the intake pan so the factory 1 piece coolant pipe will now be exposed.



3. The existing pipe can now be cut in the center with a small air saw or cut off wheel.\*



\*Important note: Care must be taken at all times to keep debris and cuttings out of the engine.

4. Remove the factory pipe in 2 pieces. The front will require some twisting or careful prying to break the bond of the front seal.



5. Remove the remaining front seal material with a pick and wire brush taking care not to damage the seal housing.



6. Remove the old rear o-ring seal taking the same care.



7. Carefully clean the front seal gallery. Lubricate all surfaces of the front seal liberally with the grease provided in the kit (item#5).



8. Fully fit front seal (item#7) into housing taking care to make sure the \*flat profile of the seal faces the timing cover (forward). (**\*this is critical to a proper installation**).



Note: Above picture shows seal installed in place.

9. Perform the same lubricating and fitting operation to the rear o-ring (item #8); noting however there is no orientation necessary for this seal.



10. Fit the 3 supplied inner tube o-rings (item #4) carefully to the front tube section so each is fully seated into the machined grooves on the tube; lubricate with provided grease.

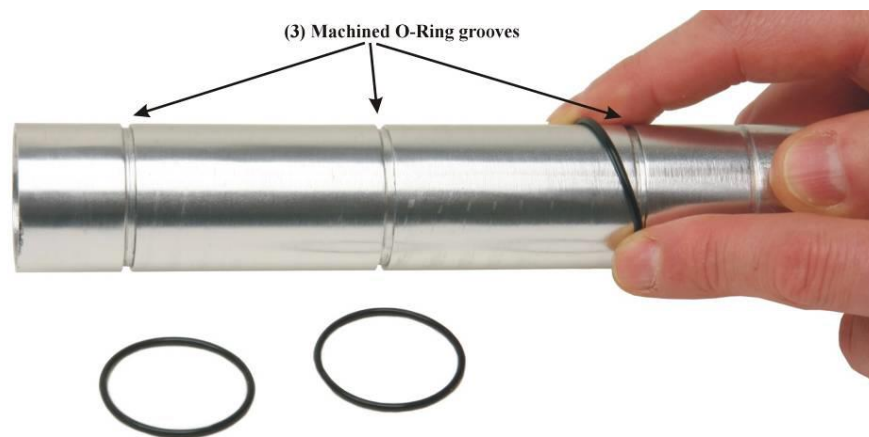

11. Fit inner (item #1) and outer tube (item #2) sections together taking care not to pinch or damage any of the pipe sealing rings & collapse completely.

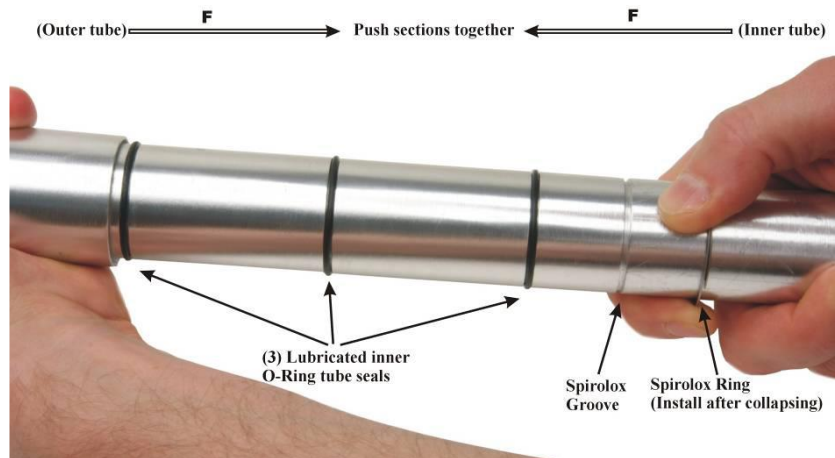

Then install the spirolox (item #6) around the smaller inner tube and position it by sliding it up against the end of the larger outer tube.

12. Taking the assembled and collapsed pipe grease the front tube (smaller diameter pipe) and fit squarely into the front seal taking great care not to pinch or damage it.



13. With a soft faced pry tool, lever the tube forward until it stops against the timing cover.



14. Grabbing both sections of the tube firmly, hold the front half in place taking care to position the rear tube with the wide angle step facing upwards. Then slide the rear section back into the block until it clicks home, exposing the Spirolux locking groove.

15. This should just expose the ring groove allowing the pre-installed locking ring to be slid forward into place.



**\*Only as required:** If after fully seating the tube into the block the snap ring groove is beyond the end of the rear tube half, installation of shims will be required. Casting variations during block manufacturing may make this simple procedure necessary.

16. \*Measure the distance from the rear edge of the ring groove to the rear tube end in thousandths of an inch.



\*This procedure needs to be completed with pipe fitted into the engine. Pipe is removed for illustration purposes in the photo.

17. \*Slide rear tube section forward again, fit the appropriate shim stack (item #3) (equaling the previous measurement) and slide rear tube back into block until Spirolux ring groove is just exposed.

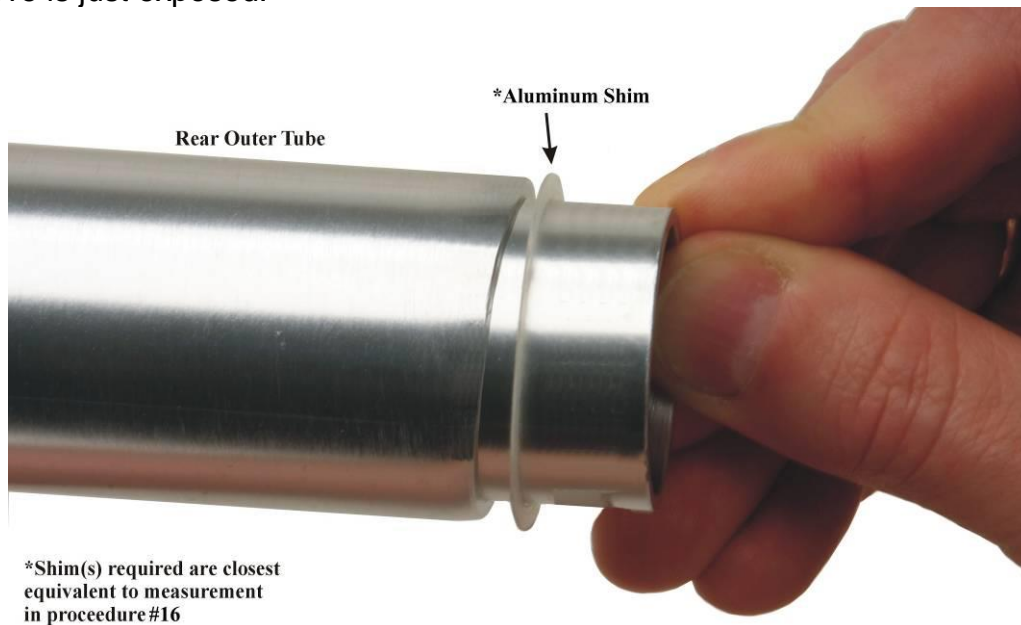

18. \*After re-seating the tube in the block the lock ring groove should now be exposed with no slop; push spiral lock ring forward into groove locking tube in place.



19. Fit new intake pan gasket # 11 14 7 507 278 (not provided) and reassemble per the factory workshop manual.\*

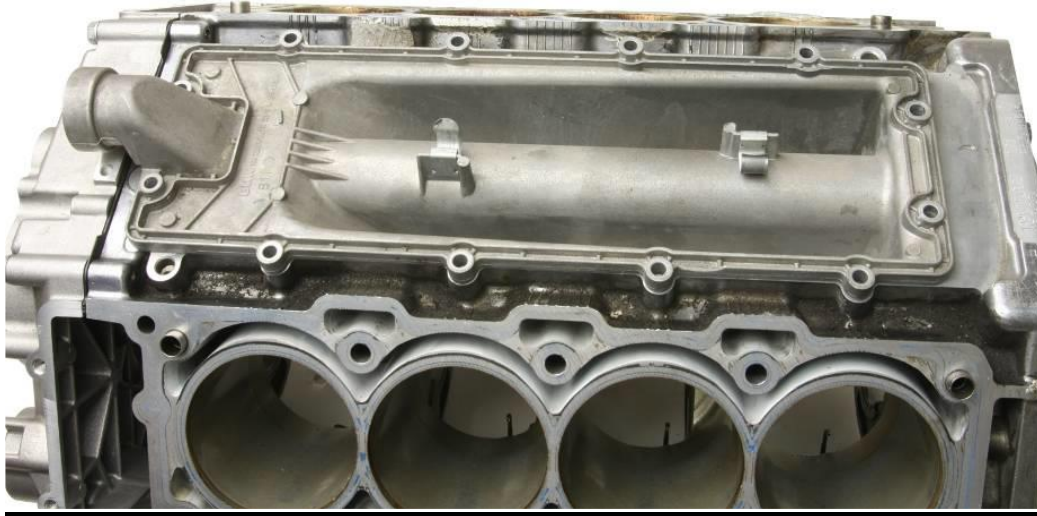

**\*Important note:** A cooling system pressure check is recommended once all the appropriate components are installed to ensure pipe was installed correctly.