



Vintage Parts™

HANDS-FREE KEYLESS ENTRY

AUTH500



Mount in Dry Location

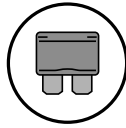

Install Fuses



Good Ground Required

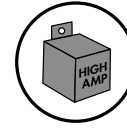

Use High Amp Relay

Remote Transmitter

Turn power on. For a successful communication between the main unit and transmitter the LED on the transmitter will blink 4 times. If unsuccessful, the LED will only blink 3 times.

If the voltage of the transmitter is lower than 2.3V in status of Anti-hijack On, the brain unit will beep 3 times to remind you.

Brain Unit Functions

1. The transmitter is in service range:

Once the ignition is ON, the brain unit will start to work and detect the transmitter. A melody of music will emit from the brain unit, meaning the communication is successful. The engine can be started at this status.
2. The transmitter is out of service range and the Anti-hijacking is ON (default setting):
 - a. Once the ignition is ON, the brain unit will begin to work and detect the transmitter. If the transmitter is out of service range, after 8 seconds, the siren will chirp for 5 seconds, following 5 seconds of urgent chirping. The engine is now locked. You can drive when the transmitter is again detected by the brain.
 - b. In case the power is run down or the transmitter malfunctions during driving, the brain unit will not detect the transmitter. After 30 seconds the siren will chirp for 25 seconds, following 5 seconds of urgent chirping. The engine is now locked. You can drive when the transmitter is again detected by the brain unit.
3. The transmitter is out of service range and the Anti-hijacking is OFF:

Once the ignition is ON, the brain unit will begin to work and detect the transmitter. If the transmitter is out of service range, the brain unit can not detect the transmitter. After 12 seconds, the engine will lock. You can drive when the transmitter is again detected by the brain unit.

Function Modes

There are 5 function modes:

- Code learning mode
- Password setting mode
- Service mode
- Anti-hijacking ON mode
- Anti-hijacking OFF mode

To go into function settings, the transmitter must be kept out of service range from the brain unit and you must enter the correct password (3 digit numbers, factory default setting is "111") following the process below.

1. Turn the ignition ON to start working the brain unit, keeping the transmitter out of range.
 - a. If the Anti-hijacking function is ON, wait 8 seconds, then turn the ignition OFF. Then turn the ignition back on immediately (interval of a half of a second from ACC OFF to ACC ON).
 - b. If the Anti-hijacking function is OFF, wait 12 seconds for a sound to emit, then enter the first digit number of your password. Following 10 signal tones will emit. Count the tones coincided with the password number and turn your ignition OFF.
2. Turn your ignition ON. After 2 sounds emit, enter the second digit of your password. 10 signal tones will emit accordingly. Count the tones coincided with your password number and turn the ignition OFF.

USER GUIDE AND INSTALLATION MANUAL

HANDS-FREE KEYLESS ENTRY

3. Turn your ignition ON. After 3 sounds emit, enter the third number of your password. 10 signal tones will emit accordingly. Count the tones coincided with your password number and turn your ignition OFF.
4. Turn your ignition ON. If the password is NOT correct, a melody of music will emit and lock the engine. Turn the ACC OFF, and ACC ON again. The system will be on the status of password entering. If the password input is correct, 5 signal sounds will be emitted (each signal will last for 5 seconds).

For entering the code learning mode, the ignition should be turned off when you hear the first signal sound.

For entering password setting mode, the ignition should be turned off when you hear the second signal sound.

For entering service mode, the ignition should be turned off when you hear the third signal sound.

For entering Anti-hijacking OFF mode, the ignition should be turned off when you hear the fourth signal sound.

For entering Anti-hijacking ON mode, the ignition should be turned off when you hear the fifth signal sound.

5. Code Learning Mode

Five remote transmitters are allowed to be programmed. Be sure they are full power and always keep all transmitters from the service range before programming. Enter code learning mode (please review entering functions settings) and turn your ignition on to start the engine. A sound will emit to remind you. Then, one by one, take the transmitters into the service range for code learning. 3 sounds will emit as confirmation of which remote transmitter is finished programing. All transmitters must be programmed in together, as it will delete the previous programming record during programming. Die out the engine to exit the code learning mode.

Note: For learning the transmitters new code, avoid the extra remote transmitters store code by learning the new

transmitter code one by one, all at one time.

6. Password Setting Mode

There are 3 digital numbers in your password. Shift the system to password setting mode (please review entering functions settings).

- a. Turn ON the ignition. Sound will emit reminding you to enter the first number of your password. 10 single tones will then emit. Count the tones coincided with your password number. Then turn your ignition OFF.
- b. Turn your ignition back ON. 2 sounds will emit reminding you to enter the second number of your password. 10 single tones will then emit. Count the tones coincided with your password number. Then turn your ignition OFF.
- c. Turn your ignition back ON. 3 sounds will emit reminding you to enter the third number of your password. 10 single tones will then emit. Count the tones coincided with the password number. The turn your ignition OFF.

When you have finished the above process, 3 password numbers will be entered in as the status. However, these numbers should be confirmed to be effective. Just follow the process below to confirm your password.

- d. Turn your ignition ON. 1 sound will emit reminding you to enter the first number of your password. 10 double-tones will then emit. Count the tones coincided with your password number. Then turn your ignition OFF to confirm the first number of your password.
- e. Turn your ignition ON again. 2 sounds will emit reminding you to enter the second number of your password. 10 double-tones will then emit. Count the tones coincided with your password number. Then turn your ignition OFF to confirm the second number of your password.
- f. Turn your ignition ON again. 3 sounds will emit reminding you to enter the third number of your

USER GUIDE AND INSTALLATION MANUAL

password. 10 double-tones will then emit. Count the tones coincided with the password number. Then turn your ignition OFF to confirm the third number of your password.

If the password has been confirmed successfully, a sound will emit reminding you that the password has changed in the next ignition on. If the new password has failed to confirm, the password will remain unchanged. Each time a number is entered, the ignition should be turned off, or else it will exit the mode and lock the engine until the programmed remote transmitter is in service range. The system will be on the status of password entering.

7. Service Mode

In the service mode, all system functions will be on invalid status and the siren will beep one itme per 1 minute. When the system detect and connect with the programmed transmitter for 1 and half of munutes (the interval tiem should not longer than 1 minute), a melody music will emit as reminding to exit service mode.

Note: If no programmed transmitter is detected, the system will not exit from service mode.

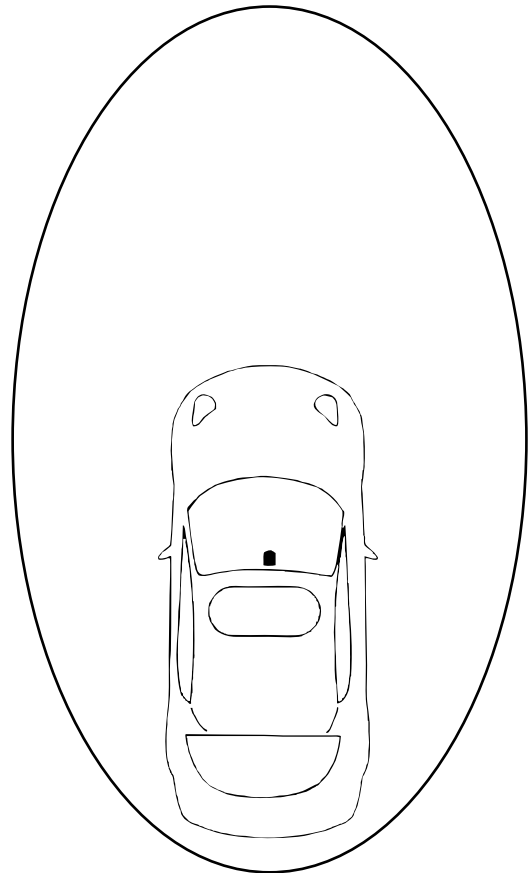
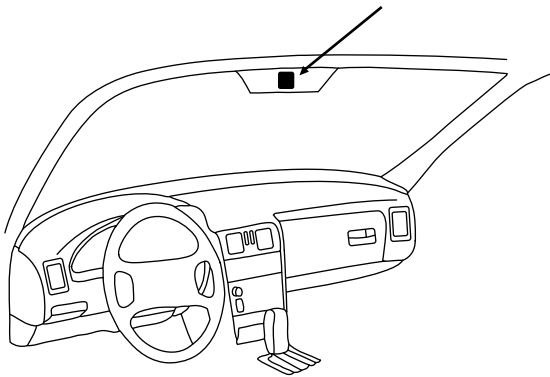

USER GUIDE AND INSTALLATION MANUAL

HANDS-FREE KEYLESS ENTRY

Basic AUTHF500 Operation

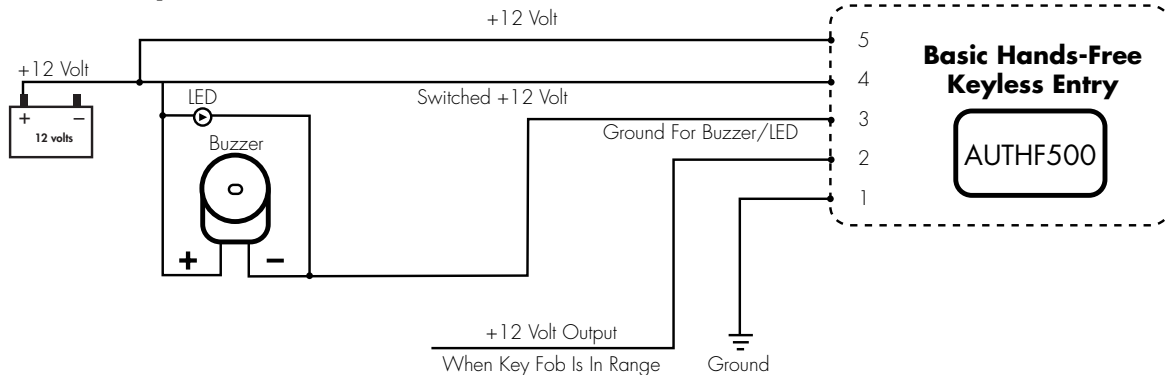

Basic AUTHF500 Operation with Ground Output

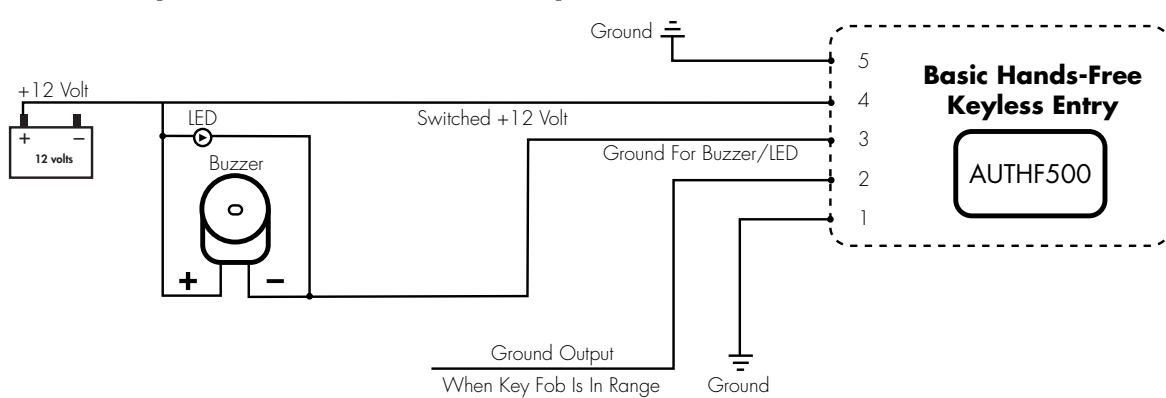

Wiring Diagram - Basic Starter Kill

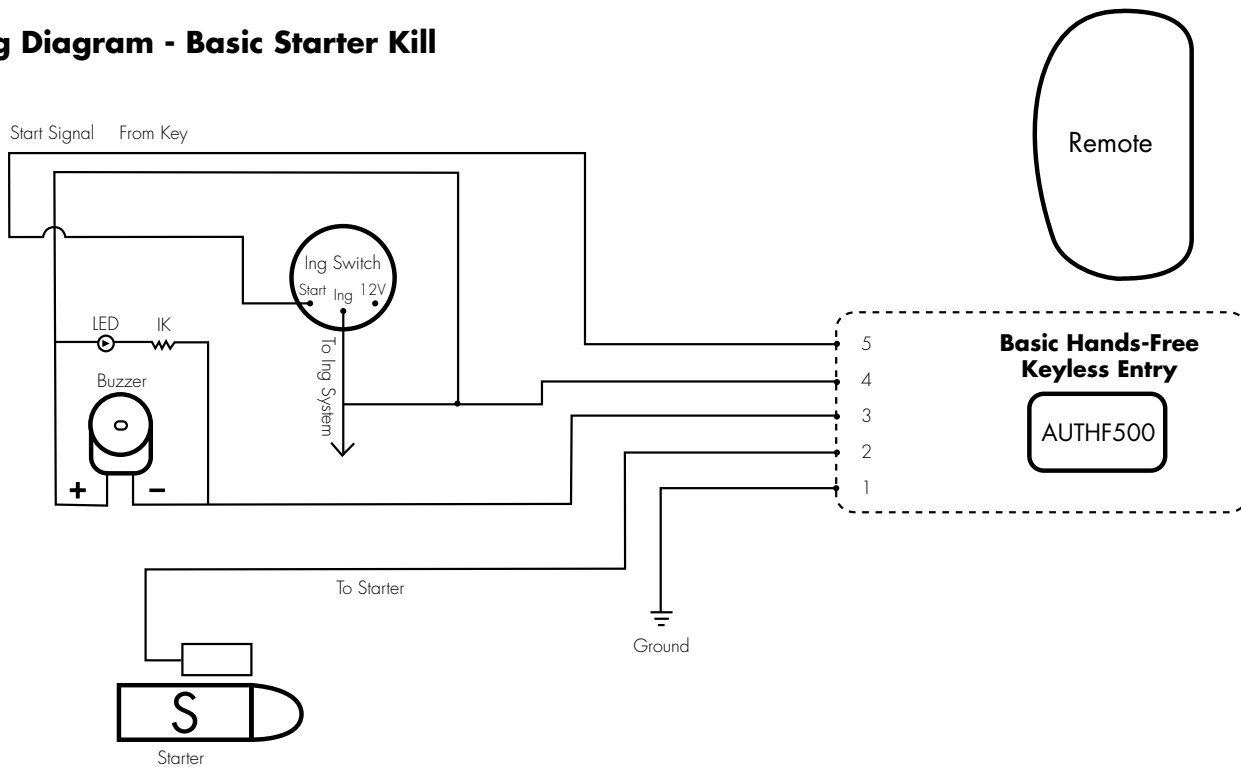

USER GUIDE AND INSTALLATION MANUAL

Remote Start For Push Button With RFID

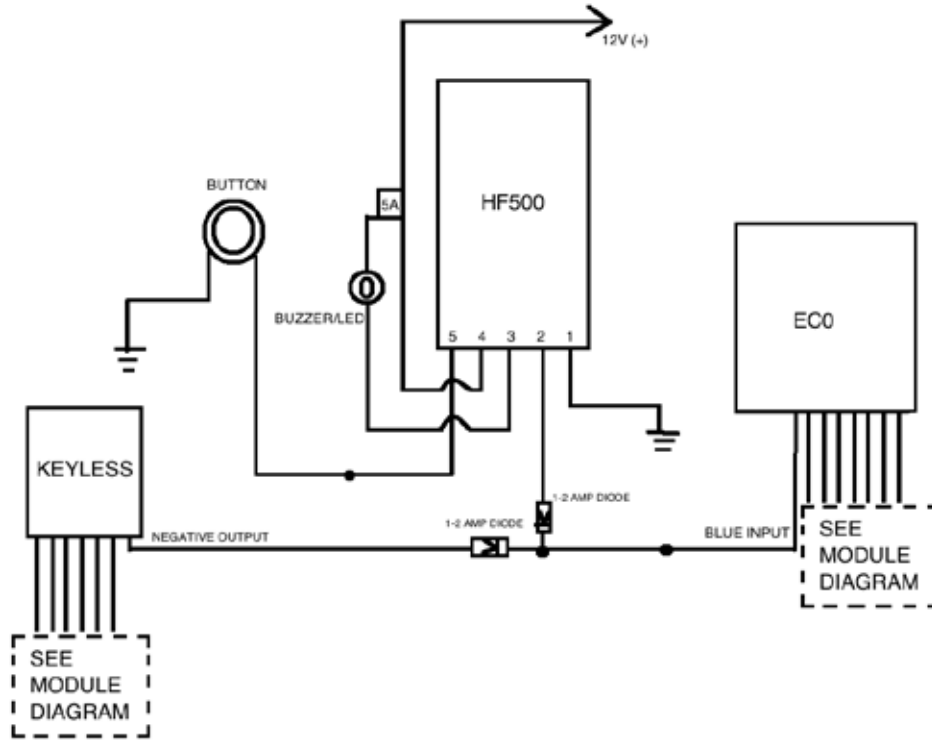

Push Button Start Diagram (Optional)

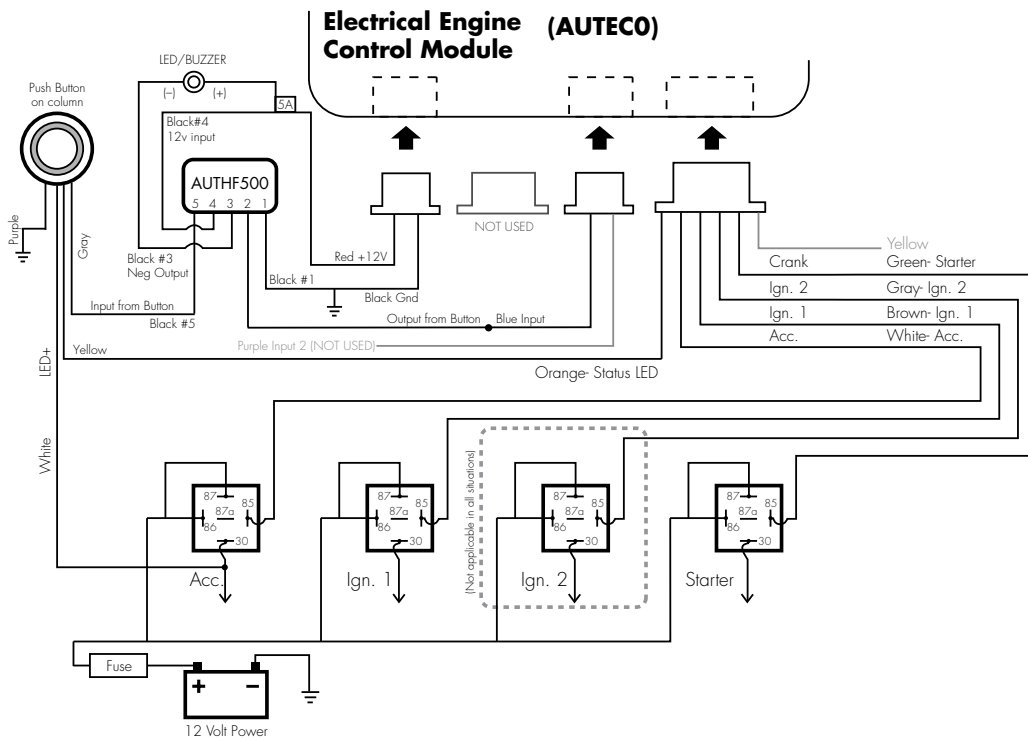

USER GUIDE AND INSTALLATION MANUAL

HANDS-FREE KEYLESS ENTRY

Proximity Unlock With RFID

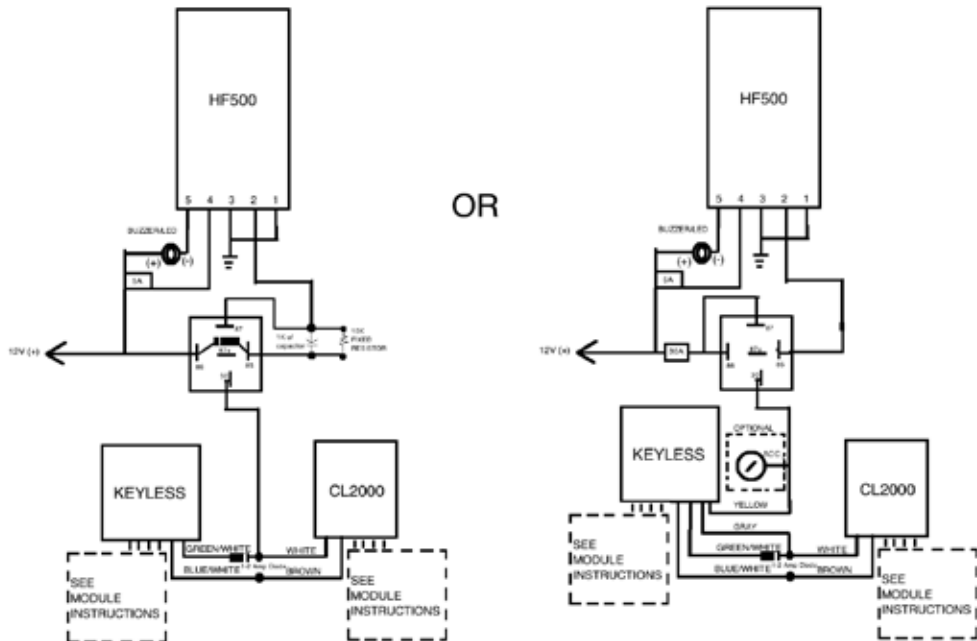

Proximity Shaved Door With Ultra Touch

