

VOLANT AIR INTAKE SYSTEMS
PART NO.: 15974
INSTALLATION INSTRUCTIONS

15974 PARTS LIST

1	VOLANT FILTER BOX	1	3 1/2" HUMPH HOSE	2	1/4" LOCK WASHERS
1	VOLANT FILTER BOX LID	2	5/16" BOLTS	2	3/8" NUTS
1	VOLANT AIR DUCT	2	3/8" BOLTS	4	1/4" RUBBER WASHERS
1	RAM FILTER W/CLAMP	4	1/4"-20 SCREWS	1	FILTER BOX BRACKET
6	#056 CLAMP	4	3/8" WASHERS	1	1/2" RUBBER GROMMET
1	3 1/2" X 2 1/2" SLEEVE	2	5/16" WASHERS	1	1/2" X 16" VINYL TRIM
1	3 1/2" X 3" SLEEVE	2	3/8" LOCK WASHERS	1	1" VINYL END CAP

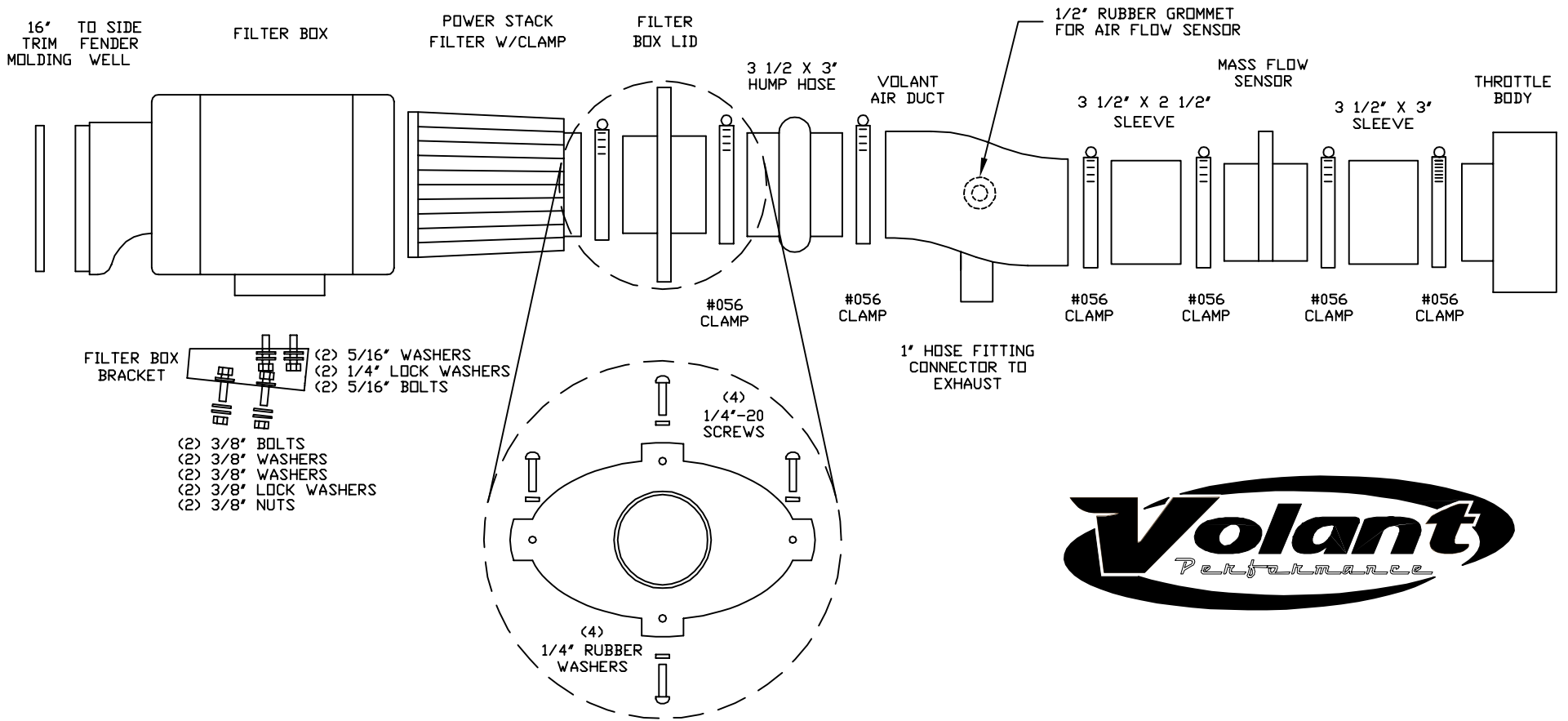



**READ INSTRUCTIONS THOROUGHLY BEFORE DISASSEMBLING.
DO NOT SKIP ANY STEPS.**

INSTALLATION INSTRUCTIONS PART NO. 15974

Installation Instructions:

1. Disconnect the negative battery cable.
2. Disconnect the stock mass flow sensor located between the resonator box that has Vortec written on it and the elbow from the stock filter box.
3. Remove the stock filter box lid by unclipping the latches and pulling it away from the bottom half.
4. Remove the bolt on the resonator box that has Vortec written on it with a 10 MM socket. Loosen the hose clamp underneath that same box. Pull resonator box off the vehicle.
5. Disconnect the air temperature sensor on the stock elbow. Remove the stock filter, elbow, and mass flow sensor away from the vehicle. Then unsnap the stock filter box housing away from the side body panel and firmly pull up and remove entire bottom half.
6. Unbolt the stock filter box bracket from the fender well and remove.
7. Insert ½" X 16" vinyl trim around fender well opening where your existing filter box was pulling air.
8. Attach the Volant filter box bracket to the Volant filter box using 5/16" bolts, 5/16" lock washers and 1/4" washers on the brackets smaller slot side. Secure with a 1/2" open wrench.
9. Before placing the Volant filter box assembly, insert both 3/8" bolts and 3/8" lock washers in the filter box bracket. Then lower and line up the bolts with the existing holes in you wheel cover. Place 3/8" nuts and 3/8" washers by hand on the other side. Slide filter box assembly back into the hole until it lines up against the fender. Tighten 3/8" nuts with a 9/16" socket and a 9/16 open wrench to hold the bolt in place.
10. Slide the 3½" hump hose and #056 clamp over the 3½" inlet on the filter box assembly. DO NOT tighten clamps until everything is in place.
11. Connect the 3½" X 2½" sleeve, mass flow sensor, 3½" X 3" sleeve and #056 clamps to the throttle body. MAKE SURE THAT SENSOR ARROW POINTS TOWARDS THROTTLE BODY.
12. Remove the air temperature sensor from the stock elbow and reinstall the sensor back into the Volant air duct.
13. Install the Volant duct between the 3½" hump hose and 3½" X 2½" sleeve. Make sure that the rubber grommet is facing the fire wall.
14. Plug in the air temperature sensor to the stock harness.
15. Make sure everything is properly connected and tighten hose clamps
16. If you own a California vehicle connect the 1" smog pump hose underneath the Volant air duct. If you do not have a 1" smog pump hose, cover opening with the 1" vinyl end cap provided.
17. Reconnect the battery cable.

WARNING: OVER TIGHTENING HARDWARE MAY ALTAR THE INTEGRITY OF THE VOLANT AIR INTAKE SYSTEM.

BEFORE ROAD TESTING

1. Start engine, leaving the transmission in park and securing the parking brake.
2. Make sure to look and listen for any unusual noises or air leaks. Repair problems if needed.
3. Once completed it will be necessary to check periodically for realignment and tightening of all connections.
4. Once all tests are completed, enjoy the performance of your new Air Intake System.

CARE AND CLEANING

Check the cotton reusable filter periodically and remove any excessive dirt build-up by tapping the filter on the ground and brushing off the loosened dirt. Clean the filter by using Volant's Filter Recharger Kit. Volant's Filter Recharger Kit is designed to restore original air flow. Re-oil every 10,000 miles without cleaning to improve filtering in sand and dirt. Clean only when dirt is very excessive or 50,000 miles.

RECOMMENDED SERVICE PARTS

RECOMMENDED SERVICE PARTS	PART NO.
REPLACEMENT FILTER	5123
PREFILTER	51909
CLEANING KIT	5100

APPLICATION GUIDE

MY	MAKE	MODEL	ENG.
96-00	GM	SILVER/SIERRA	7.4L
96-00	CHEVROLET	SUBURBAN	7.4L

INSTALL

