



(10984 – 4DR / 10982 – 2DR) JK WRANGLER MOD RACK Installation Instructions

Important Notes: Some brands of windshield light brackets and snorkels may not be compatible with the 10984 MOD Rack System. Body lifts are also not compatible with this rack system. Please keep this in mind when deciding upon any upgrades or accessories that may conflict with the racks' mounting locations. It is recommended to have an additional person to assist you during some steps of this installation process.

Kit Contents:

Item	Qty	Item	Qty
Air dam / Windshield frame	1	8mm x 25mm SS Button head screw	6
Side MOD rail - L	1	8mm Lock washer (5/16")	6
Side MOD rail - R	1	8mm Flat washer (5/16")	6
Rear MOD rail	1	3/8" x 1" Hex bolt	16
Rear leg – L	1	3/8" Nyloc nut	16
Rear leg – R	1	3/8" USS flat washer (used for both 3/8" and 7/16" bolts)	62
Rear frame mount bracket – L	1	7/16" x 1" Hex bolt	2
Rear frame mount bracket – R	1	7/16" x 2-1/2"	8
Pinch seam clamp – L	1	7/16" x 3-1/2"	8
Pinch seam clamp – R	1	7/16" Lock washer	6
Platform Latch Assembly	4	7/16" 2-way Lock Nut	12
4800 Platform	1	1/2" x 3" SS Button head screw	4
Slack brackets	4	1/2" Lock washer	4
1/4" Linchpin	4	12mm Flat washer (used with 1/2" x 3" button head for smaller diameter)	4

Phase 1: Mounting Brackets Installation

1. Install Air dam/Windshield mount (this will be much easier with a helper). **(Fig. 1)**
 - a. Remove the top three Torx bolts at each side of the windshield hinge.
 - b. If you are concerned about damaging the paint under the mounting brackets, a piece of bicycle inner tube or similar gasket material can be cut out and installed between the brackets and the A-pillar.
 - c. Prepare the mounting hardware for the Air dam by locating the [6] 8mm stainless steel button head screws, [6] lock washers, and [6] flat washers. Place a lock washer and then a standard flat washer on all [6] of the button head screws (the lock washer will be touching the head of the screw, and the flat washer will be touching the Air dam mount).
 - d. Carefully place the windshield mount and securely start all the button head screws but do not fully tighten at this time.



Fig. 1



- The rear mount brackets are a little more involved and in most cases, temporary removal of the rear bumper will be required. Take the Rear Mount Bracket - R (passenger side) and match it up with the Pinch Seam Clamp – R (pay attention to the angle where the mount and clamp come together). Loosely thread the 7/16" x 2.5" bolts along with a 7/16" lock washer and a 3/8" flat washer up through the bottom of the Rear Mount Bracket and into the Pinch Seam Clamp. (Fig. 2)



Fig. 2

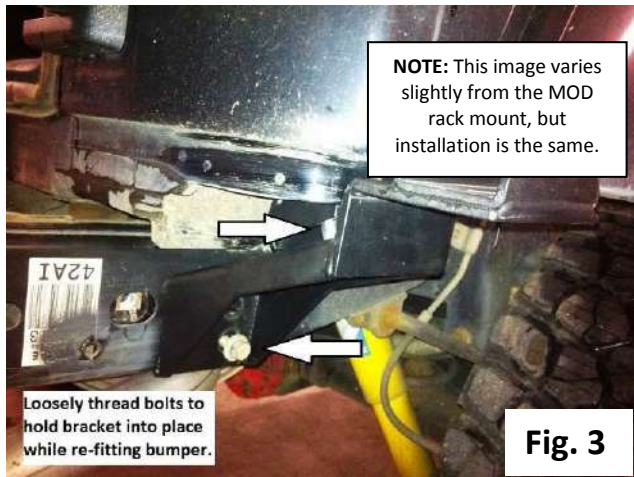

Fig. 3

Hold the assembled passenger side bracket against the side of the frame where the factory bumper mount holes are located. The pinch seam of the Jeep tub should set between the bracket and the clamp. (Fig. 3 & Fig. 5) Utilizing a factory bumper side bolt, *'loosely'* thread one through the bottom hole of the bracket into the frame. This is to hold the brackets into place while you slide the rear bumper back on. Repeat steps for the driver side.

- If you are reinstalling the factory plastic bumper, you will need to mount the bumper brackets on the outside of the Rear Mount Brackets. If you are fitting an aftermarket bumper, you most likely will be 'sandwiching' the bumper mount brackets between the frame and the Rear Mount Brackets. The lower bolt is *'loosely'* threaded into the frame so that it is easier to pull the bolt and reinsert while positioning the bumper. It can be a bit of a juggle installing the rear bumper while keeping the Rear Mount Brackets in position, so an extra set of hands is very helpful. Once you have the rear bumper set in place and the mounting holes lined up, thread the remaining factory bolts through the Rear Mount Brackets and into the frame. Make sure the MOD rack Mount Bracket is pushed up as far as possible onto the pinch seam, as well as level and even on both sides. With the brackets level and the bumper positioned to your satisfaction, tighten the factory frame bolts. After the frame bolts are tight, complete the Rear Frame Mount installation by tightening the Pinch Seam Clamp. (Fig. 4 & Fig. 5)



Fig. 4



Fig. 5



Phase 2: Rack Legs and Slack Bracket Installation

4. Place the rear legs over the mounting post on the rear frame bracket.
 - a. Position the leg with the foot at the bottom and align the top angled surface of the foot with the same orientation as the angled surface on the top of the mounting post. (The leg will bend in toward the Jeep and the smaller flange on the top should be pointing across the rear of the Jeep. The large flange will be pointing toward the front of the Jeep). **(Fig. 6)**
 - b. Align the side holes of the leg with the holes in the mounting post and place two of the 7/16 x 2-1/2" bolts with washers through the holes. **(Fig. 7)**
 - c. Place washers and 7/16" lock nuts on the other side of the leg. Start the 7/16" lock nuts but do not fully tighten at this time.
 - d. At the angled surface above the two foot cross bolts loosely start a 7/16" x 1" bolt, lock washer, and regular washer through the hole and into the threads in the mounting post, again, do not fully tighten at this time. **(Fig. 7)**
 - e. Repeat the process for the second leg and leave all hardware loose until a later step.
5. Next prepare the slack brackets at each corner before installing the MOD rails.
 - a. Begin at any corner of the vehicle (2 places on the top-outer corners of the windshield mount, and 1 place at the top of each leg). Place a 1/2" x 3" button head screw with lock washer and 12MM washer (smaller outer diameter) through the hole in the angled surface from the outside. **(Fig. 8 & Fig. 9)**





- b. From the inside install the slack bracket oriented with the tabs facing away from the head of the screw and thread the Button Head screw into the welded nut just a few turns. See **Figures 10 & 11** for orientation of the Front and Rear Slack Brackets (some components have been made transparent for visibility).
- c. Repeat at all four corners.

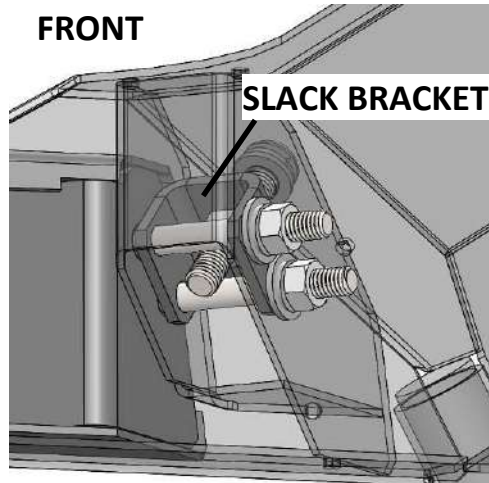

Fig. 10

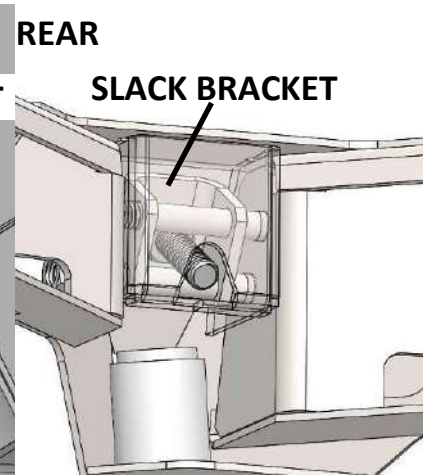

Fig. 11

Phase 3: MOD Rails installation

6. You are now ready to start installing the MOD side rails (we recommend that you find someone to help at this point).

*****HELPFUL HINT: Using a drift pin, long punch, or screwdriver will be very helpful when trying to align the cross holes to insert the bolts. *****

- a. Start with one of the side rails (they are the 2 longer ones and need to be oriented with the “WP” logo toward the rear of the vehicle).
- b. Feed one of the MOD rails in from the back side of the mounts into the corresponding sockets in the Air dam/Windshield mount, and the top of the rear leg.
- c. While holding the rail in place, insert two 7/16” x 3-1/2” hex bolts with washers through the opening at the side of the windshield mount, then through the two holes in the side rail. It may help to place the washers inside the pocket before installing the bolts to provide more clearance. Align the holes of the slack bracket and make sure both bolts go through the slack bracket holes (using the button head screw to help position the slack bracket). Lastly, pass the bolts through the last set of holes on the back side of the windshield mount. Place a washer, then a 7/16” lock nut on each bolt. Loosely start the lock nuts, but do not tighten at this time. **(Fig. 13)** (MAKE SURE YOU DO NOT LET THE RAIL HANG LOOSELY AT THE REAR OF THE VEHICLE AT ANY POINT WITHOUT BEING SUPPORTED AS THIS MAY CAUSE DAMAGE TO THE WINDSHIELD MOUNT, AND/OR THE VEHICLE!!!)



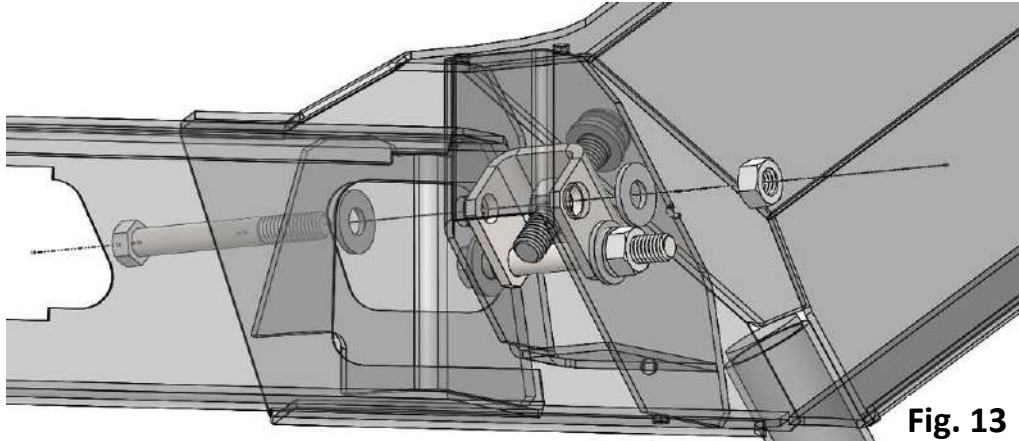

Fig. 13

- d. Next, position the rear of the side rail in the top of rear leg. At this time, place only one 7/16" x 3-1/2" hex bolt and washer through the side window at the top of the leg, then through the corresponding hole in the rail end and one side of the inner mount at the top of the leg. Align the slack bracket appropriately and pass the bolt through the slack bracket and lastly through back side of the inner mount at the top of the leg. Temporarily start a 7/16" lock nut to keep it in place while installing the rest of the rails (you will need to pull this bolt partially out later to install the rear rail). **(Fig. 14)**



- e. Repeat the above steps for the opposite side rail.

7. Once both side rails are in place, you can now position the rear rail (this can be a bit tricky and will be much easier with a helper).

- a. Remove the nuts from the bolts temporarily holding the side rails to the rear legs and remove the bolt JUST enough to provide clearance to position the rear rail. **(Fig. 15)** MAKE SURE THAT BOTH SIDE RAILS ARE SUPPORTED DURING THIS PROCESS! IF ANY RAIL COMES LOOSE FROM THE TOP OF THE LEG AND FALLS, DAMAGE TO THE RACK AND/OR THE VEHICLE MAY OCCUR!!!

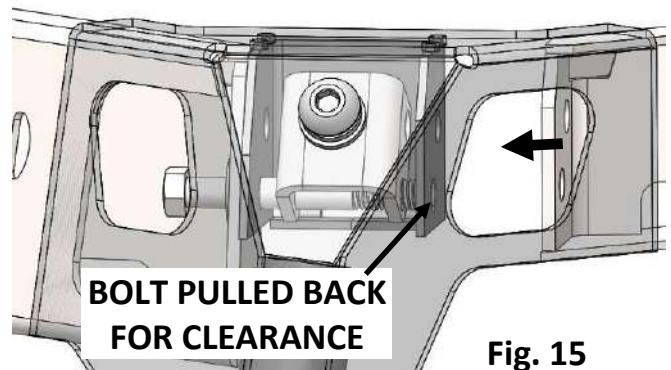

Fig. 15



-
- b. Once the rear rail is in place re-insert the bolts from the previous step THROUGH the corresponding hole in the end of the rear rail and place a washer then 7/16" lock nut on each bolt. Loosely start the nuts but do not tighten at this time. (Fig. 16)

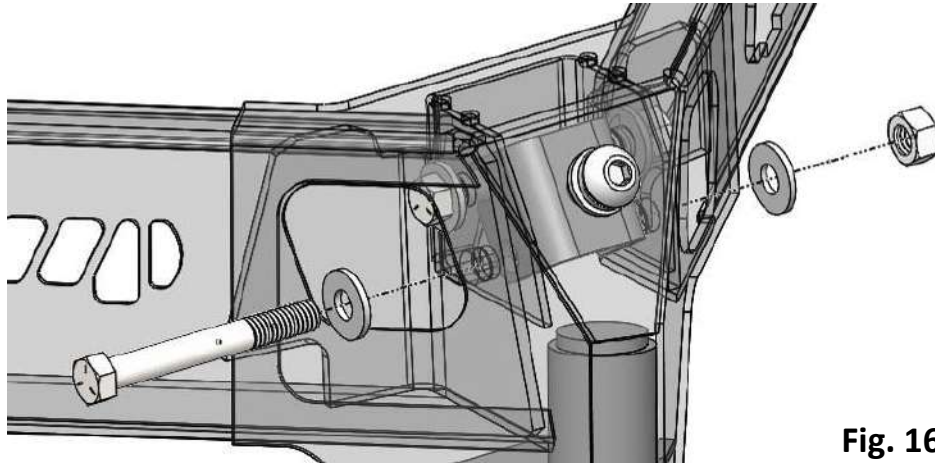

Fig. 16

- c. Now place the two remaining 7/16" x 3.5" bolts, washers, and nuts from the side rail through the empty cross holes at the top of each leg in the same manner as above. (Fig. 16)

Phase 4: Tightening Sub-frame Hardware

8. You should now have all your mounts, rails, and corresponding hardware loosely in place. It is time to start tightening the hardware to firmly set the MOD rack sub-frame. The slack bracket system is designed to pull all of the bolted connections tight and create an extremely rigid bolted structure. To ensure proper installation and a secure rack, please carefully follow the procedure below and tighten everything in the correct order. Begin at the four top corners of the rack;
- Make sure the rack is centered and even on the vehicle.
 - At the top outer corners of the front Air dam/Windshield mount, run the 7/16" locknuts down on to the 7/16" x 3-1/2" hex cross bolts at each side until **JUST BEFORE THEY ARE TIGHT** (do not fully tighten, leave just slightly loose until the slack bracket has been tightened).
 - To pull each corner tight, tighten the large 1/2" button head screw threaded into the slack bracket with an Allen wrench until snug. Make sure both corners are snug then proceed to the next step for the final tightening of the four Air dam cross bolts.
 - Once the front, top two corners have been pulled tight, finish by tightening the locknuts on the 7/16" x 3-1/2" hex cross bolts to completely secure the corners. It is best to turn the nut instead of the bolt because the bolt will be pinched by the slack bracket.
 - Make sure that you have tightened all four hex cross bolts and both button head slack bracket screws that are at the top corners of the Air Dam / Windshield mount.
 - Next, secure the rear corners at the top of the legs in the same manner. Run each 7/16" locknut on to the 7/16" x 3-1/2" hex cross bolt until **JUST BEFORE THEY ARE COMPLETELY TIGHT**, then pull the whole corner tight with the 1/2" x 3" button head screw threaded into the slack brackets. Finally, tighten the locknuts on the 7/16" x 3-1/2" cross bolts to completely secure the rear leg upper corners.





9. With all four top corners and slack brackets completely tight and secure, it is now time to tighten all the connections to the Air dam A-pillar mounts at the windshield hinge installed in step 1 and the rear frame mounts installed in step 2.
- Using an Allen wrench, tighten the six 8mm button head screws that hold the Air dam mount to the windshield hinge (3 per side). Do not overtighten to avoid stripping the threads.
 - Tighten the feet at the bottom of the rear legs to the rear frame mounts. First tighten the bolts on the angled surface at the top of the foot to remove slack (**Fig. 17**), then completely tighten the two lock nuts on the side of each foot.
10. Your sub-frame installation is now complete.



Phase 5: Platform and Quick-release Latch Assembly and Installation

11. Next, prepare the platform by attaching the quick-release latches.
- Attach a latch to each of the four mounting buckets of the platform using four 3/8" x 1" Hex bolts, eight washers, and four 3/8" Nyloc nuts per latch as shown below in **Figure 18**. Install the hardware, but do not fully tighten at this time. Tighten the hardware enough to hold the latch close to the platform mounting bucket, but loose enough to slide around slightly. You can choose the orientation of the platform based on your preference. **Figure 18** shows the platform orientation with the angled bars forward, you can position the platform with the angled bars toward the rear but the same latch placement will apply. When using the optional front platform (Warrior Part # 10103) the most appealing orientation is to have the straight bars of both platforms adjacent to each other in the center of the rack. The latches may be positioned in various configurations if you find a need to change due to your specific application, however, the configuration shown below in **Figure 18** is recommended.

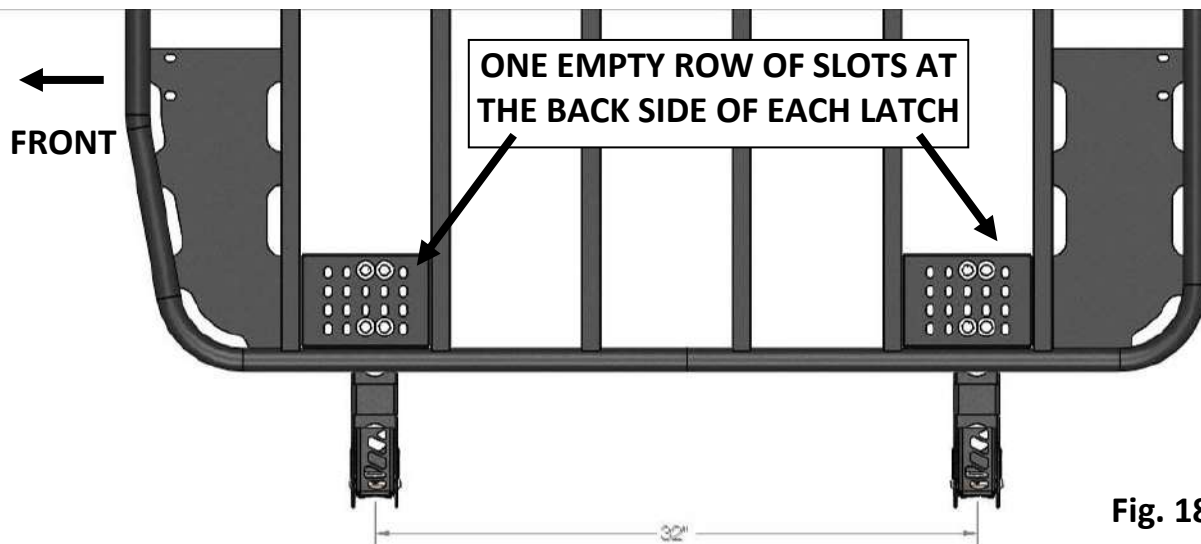
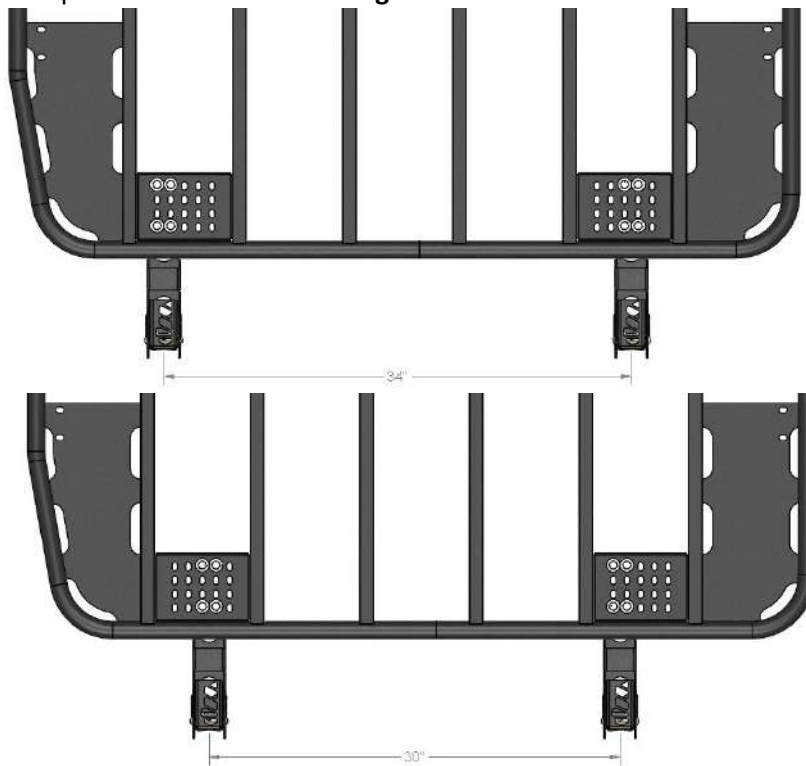

Fig. 18



- b. In order for the latch to interface correctly with the side MOD rail, the center-to-center spacing of the latches front to back MUST be an EVEN NUMBERED WHOLE INCH INCREMENT (i.e. 30", 32", or 34" etc.). This spacing is required so that the latch hooks will correctly align with the corresponding staggered notches in the MOD rail. Failure to correctly place the latch hooks in the recessed notch may result in shifting and/or release of the platform from the sub-frame. The centerline spread in the suggested configuration is 32", however, latch centerline spreads of 30", 32", and 34" are possible. Although there are many possible latch configurations possible when attaching to the platform, a few additional examples are shown below in **Figure 19**.



12. After all the latches have been attached to the platform, the final step is to carefully position the platform on the sub-frame, clamp the latches to the MOD side rail, and tighten the 3/8" latch-to-platform bucket mounting hardware. A helper will again be very helpful when lifting and positioning the platform.

- a. To prepare the platform and latches to be lifted onto the rail, you may find it beneficial to swing the silver latch hooks all the way out and screw them against the latch handle body until they stay in position. (**Fig. 20**) By tightening the latch hooks against the latch handle, you prevent them from dangling and getting in the way when setting the latches on top of the rails.



Fig. 20



- b. Now carefully position the platform on the sub-frame rails. The latches should still be slightly loose allowing them to move slightly so they may correctly sit on the rails. Although you may position the platform anywhere you like along the rail, the suggested position is shown in **Figure 21** with the rear latch hook centered in the rear cutout of the MOD rail. Please note that the latch hook must engage with a recessed notch in the MOD rail cutout. (DO NOT CLAMP THE LACH HOOK ON A RAISED TAB OF THE MOD RAIL CUTOUT!!! CLAMPING ON A RAISED TAB WILL NOT ADEQUATELY SECURE THE PLATFORM!!!)



- c. Now Clamp the latches onto the MOD rail. You can adjust the tension of the latch by screwing the hook in or out of the latch handle. Screwing the hook in will make the latch tighter, and unscrewing the hook will make the latch looser. Adjust the hook at all four latches so that the latch handle will close with some resistance (you do not need to overtighten the latches).
- d. Once all four latches are clamped down, make sure the platform is square and centered on the MOD rack sub-frame. After centering the platform, you tighten the remaining sixteen 3/8" bolts attaching the Latches to the platform, but be careful not to move the platform out of position before the hardware is tight.
- e. The final installation step is to install the secondary safety on each latch. Some Lynch Pins have been provided (please note that they are not long enough to pass through both sides of the latch). You may use these Lynch Pins to prevent accidental opening of the MOD rail latches. You may also choose a bolt and nut combination if you prefer, or even long-shackled padlocks for increased security. (**Fig. 22**)





-
13. Double check that all hardware has been tightened. You may now enjoy your new Warrior Products MOD rack! You can position the Platform anywhere along the MOD rail, or even leave the Platform at home in the garage while not in use. Additionally, you can remove the hardtop Freedom Panels without disturbing the Platform (if mounted in the rearward position) or the sub-frame. The hardtop can be removed simply by sliding it out the back of the jeep. With the platform removed, the soft top can be opened or closed without removing the sub-frame by folding it between the side rails.



QUALITY



INTEGRITY



INNOVATION



SERVICE

Discover a comprehensive collection of roof racks and cargo carriers on our website.