



Protecting Your Adventure Lifestyle

SR 180-3 SYSTEM

87-95 WRANGLER

INSTALLATION INSTRUCTIONS

***** READ ALL INSTRUCTIONS BEFORE BEGINNING INSTALLATION*****

To install your WARRIOR SR 180 SYSTEM, ensure your jeep is on a level surface before removal of the front wheels. You will need jack stands or a way to support your axle and your chassis before you begin installing your new kit. If you have aftermarket springs you must verify your vehicles' wheelbase. The original location of your housing is very important, so measure your wheelbase before starting any work. Remember, your new kit was designed to fit with factory springs. Aftermarket springs may alter this wheelbase and the kit may have to be adjusted accordingly. Please read the instructions completely and understand all the aspects of the kit before you begin.

*****ALL WELDING MUST BE DONE BY A CERTIFIED WELDER*****

PREP THE JEEP:

1. Make all necessary measurements and notes before jacking up the Jeep and removing the front wheels.
2. Loosen the front wheel lug nuts and lift the front of the Jeep supporting the frame with jack stands. Securely position the jack stands just behind the rear leaf spring mounts and adjust them high enough so that the entire front of the Jeep is off the ground. Shake the Jeep to be certain it is stable and secure.
3. Remove the front wheels and set aside.
4. Position a floor jack underneath the differential housing and raise it to support the axle while you remove the front u-bolts (4). Once the u-bolts have been removed, raise the front axle up a few inches with the floor jack and support it with 2 additional jack stands.
5. You should now be able to remove both front leaf springs completely from the Jeep. Remove the stock spring bushings on both ends of the front leaf springs and replace them with the polyurethane bushings supplied in your kit.
6. Remove both front shackle brackets from the frame. They are welded on and must be cut off with all surfaces smoothed for installation of the SR 180-3 front cross member.

*****IF YOU ARE IN DOUBT, CALL FACTORY BEFORE WELDING*****

CROSS MEMBER INSTALLATION:

1. You will be installing the SR 180-3 front cross member to the front frame horns. There are two holes on the ends of the frames horns that are used to attach the stock bumper to the frame. The SR 180-3 front cross member leaf spring mounting holes are to be positioned directly in line with these two holes. (See following image)



Protecting Your Adventure Lifestyle

2. Weld the SR 180-3 cross member on the front, back, and both sides. If it was removed, be sure to reinstall the lower bumper bolt before installing front leaf springs.
3. Remove the front leaf spring rear frame brackets from the frame and grind smooth to prep for welding.

Warrior Rear Shackle Hanger Installation:

1. Measure 45_” from the center of the front leaf spring mounting hole on your new cross member to the frame and scribe a line on the frame. Now, clamp or tack-weld the rear Warrior shackle hanger unto the frame so the measurement of 45_” is centered in middle of hole on the mount. This measurement was taken off of OEM leaf springs and may vary slightly depending upon your springs. Before welding, be sure your new shackle will look like the picture below with the weight of the vehicle on the springs. Test fit now by installing the shackle hanger bushings, the shackle and the leaf spring. For best result, install the tires and lightly set the vehicle on the ground to compare it to the diagram below. Do not tighten bolts. Adjust the frame bracket as needed on the frame to make it similar to our diagram.
2. Once the shackle angle has been set, proceed with the welding of the frame bracket in accordance with the diagram below. Do not completely perimeter weld the bracket. Failure to weld the mount in the fashion shown below will immediately void this products warranty.

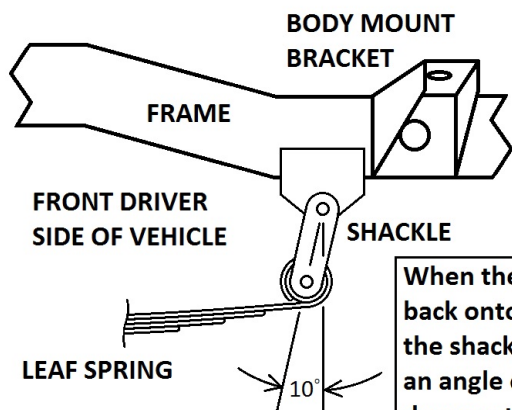
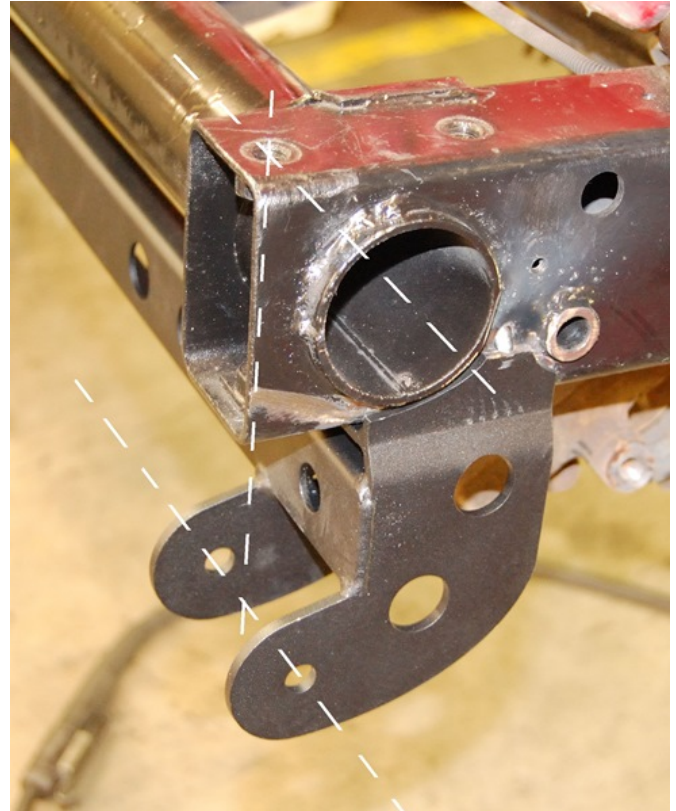

When the Jeep is set back onto the ground, the shackle should have an angle of approx. 10 degrees towards the front of the Jeep.

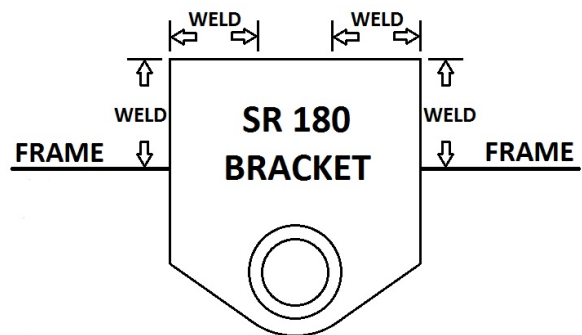



Protecting Your Adventure Lifestyle

3. If not done in the previous steps, install the front leaf springs with your Warrior shackles. The front bolts are 4_” x _” brass plated and the rear bolts are 4_” x _” zinc plated. Tighten the front leaf spring bolt to 45 ft. lbs., rear leaf spring bolt to 35 ft. lbs., and shackle frame bracket to 35 ft. lbs.
4. Lower the front axle housing back onto leaf springs while be certain the leaf spring locating pin is in the correct location. Re-install the front u-bolts and replace any that may have been stripped upon disassembly (not supplied in kit). Torque u-bolts to factory specifications.
5. Install the front wheels and tires and tighten to factory specifications.
6. Double-check all bolts for tightness.
7. Clean and paint all bare metal and welds after they have had time to cool.
8. Lower the Jeep to the floor and take for a short test drive. Re-inspect all bolts for tightness and check that all welds are structurally solid.
9. Your assembly is complete! Enjoy the way your Jeep now drives with your SR-180 SYSTEM.

*****AGAIN... ALL WELDING MUST BE DONE BY A CERTIFIED WELDER*****