

INSTALLATION INSTRUCTIONS

ACTIVE CRUISE CONTROL RELOCATOR

WESTiN®

APPLICATION:
2019-2020 Ford Ranger
PART NUMBER:
58-40015

CONTENT			
ITEM	QUANTITY	DESCRIPTION	TOOLS NEEDED
1	1	CRUISE CONTROL MAIN BRACKET	ALLEN WRENCH
2	1	CRUISE CONTROL FRONT PLATE	RATCHET
3	9	M6 BUTTON HEAD BOLT	TORQUE WRENCH
4	18	M6 FLAT WASHER	
5	9	M6 SERRATED FLANGE NUT	

ANTI-SEIZE LUBRICANT MUST BE USED ON ALL STAINLESS STEEL FASTENERS TO PREVENT THREAD DAMAGE AND GALLING

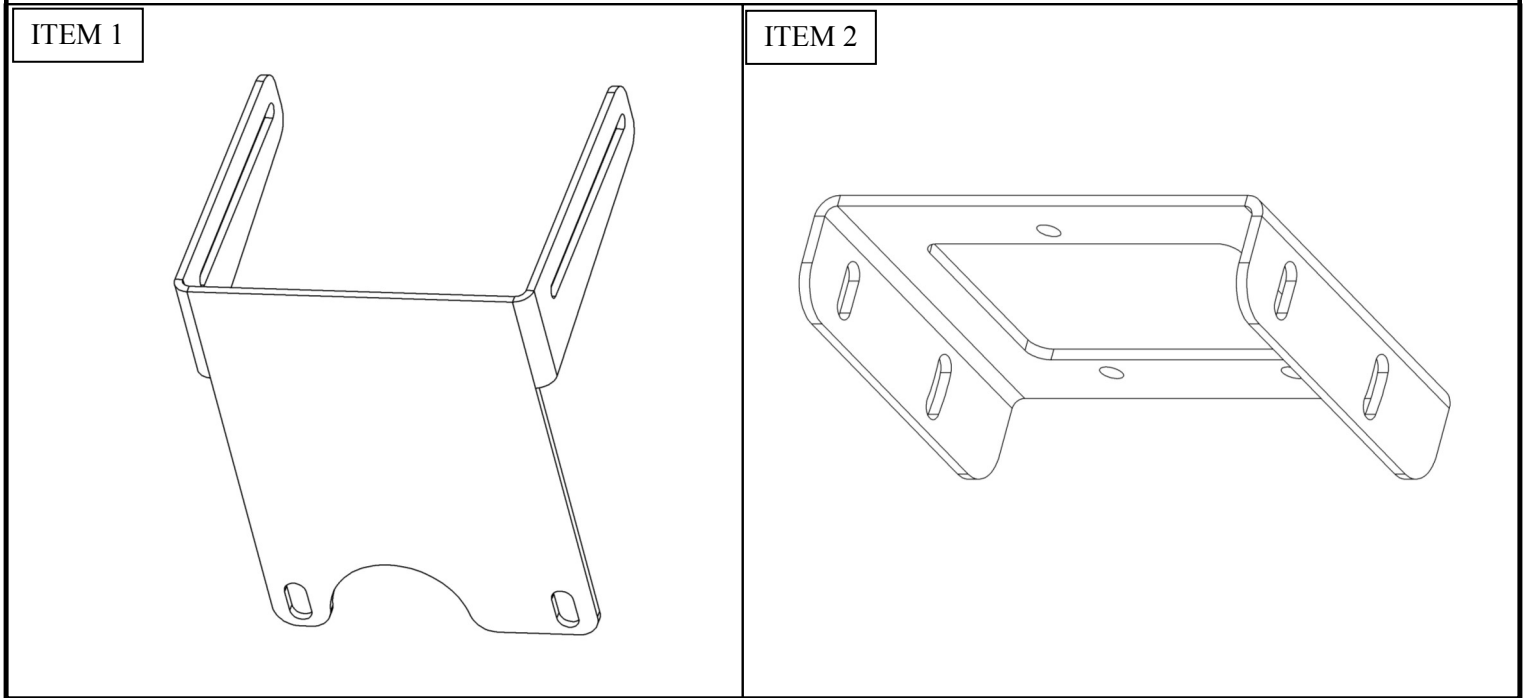

PROCEDURE

1. Remove contents from box, verify if all parts listed are present and free from damage.
Carefully read and understand all instructions before attempting installation.
Failure to identify damage before installation could lead to a rejection of any claim.

WESTiN

2. Remove the Active Cruise Control (ACC) module from the factory bumper. Note the orientation of it as it will be re-installed the same way.
3. Locate the front bracket (2). Using supplied M6 hardware, mount the ACC module to the bracket. See Figure 1-2.

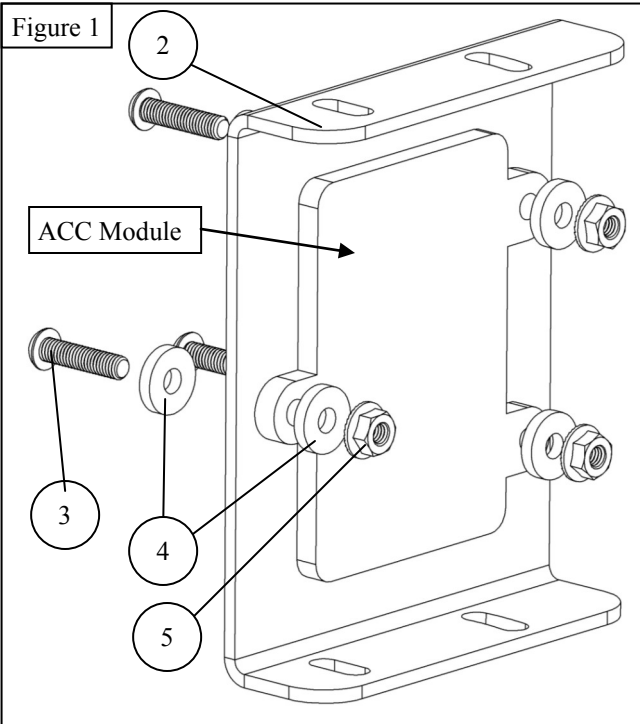

4. Locate the main mounting bracket. Using supplied M6 hardware, assemble the main bracket to the front bracket. See Figure 3.

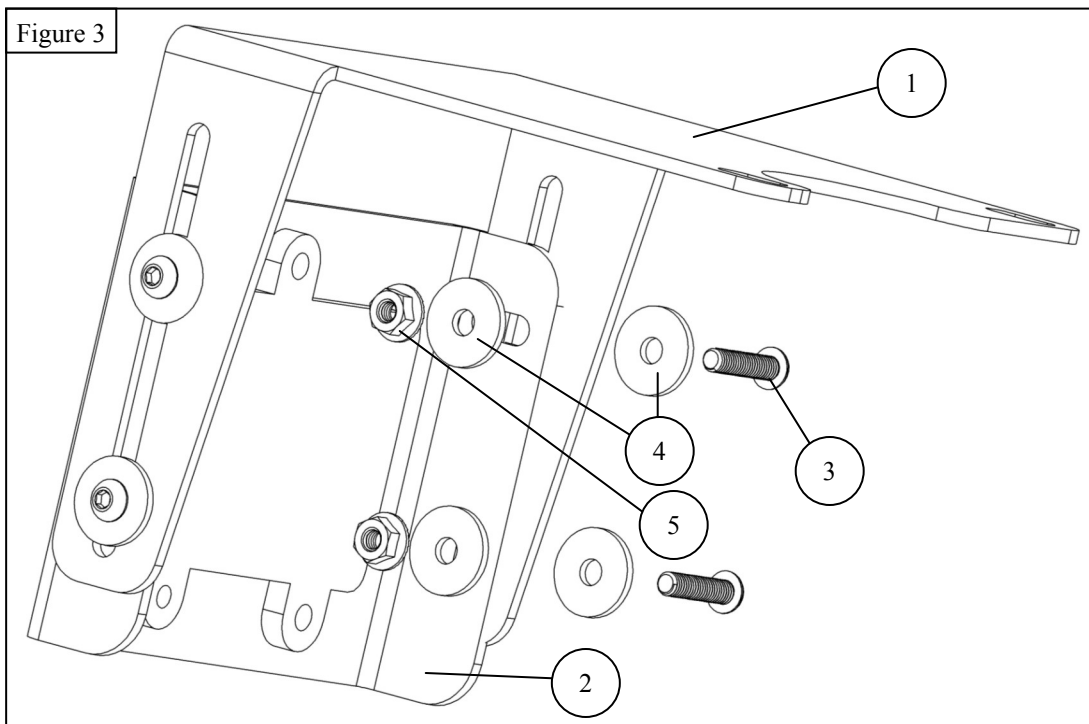



WARNING



Failure to follow these instructions could lead to death, personal injury, and / or property damage.

Failure to follow these instructions could lead to death, personal injury, and / or property damage.

FASTENERS:

All Westin supplied fasteners must be utilized and installed in accordance with the installation instructions and apply torque to the specifications as defined. **DOUBLE CHECK ALL FASTENERS BEFORE INITIAL USE, AND PERIODICALLY IN THE FUTURE TO ENSURE PROPER FUNCTION AND SAFETY.**

DRILLING:

Most Westin products do not require drilling for installation. If drilling is defined as required, use caution when drilling a vehicle. **FAILURE TO REVIEW AN AREA TO BE DRILLED MAY RESULT IN PERSONAL INJURY AND/OR INJURY TO OTHERS AS WELL AS VEHICLE DAMAGE.**

EYE PROTECTION:

ALWAYS WEAR SAFETY GLASSES OR GOGGLES DURING THE INSTALLATION PROCESS TO AVOID PERSONAL INJURY.

MAXIMUM TOWING/CARRYING CAPACITY: (if applicable)

The Westin Receiver Hitches will have a visible tow rating label affixed directly on the product. User should never exceed the vehicle manufacturers maximum tow and weight rating regardless of the capacity of the hitch. **FAILURE TO FOLLOW THESE GUIDELINES WILL VOID THE WESTIN WARRANTY AND MAY RESULT IN PERSONAL INJURY AND/OR INJURY TO OTHERS AS WELL AS VEHICLE DAMAGE.**

FOR CALIFORNIA RESIDENTS ONLY-PROP 65 WARNING:

Some products may contain chemicals such as DEHP, which can cause cancer, birth defects or other reproductive harm.



Learn more about off-road bumpers we have.