

INSTALLATION INSTRUCTIONS



WJ2 REAR BUMPER

WJ2 REAR BUMPER WITH TIRE CARRIER

APPLICATION:

2018-2019 Jeep Wrangler JL with Sensors (Excl. Wrangler JK)

PART NUMBER:

59-82045, 59-82055

PART ONE: WJ2 REAR BUMPER INSTALLATION ONLY

See Page 9 for components associated with Tire Carrier Install

CONTENT			
ITEM	QUANTITY	DESCRIPTION	TOOLS NEEDED
1	1	REAR BUMPER ASSEMBLY	18MM SOCKET
2	2	M14 NUT PLATE	18MM WRENCH
3	1	LICENSE PLATE RELOCATOR BRACKET	10MM WRENCH
4	1	TRAILER PLUG RELOCATOR BRACKET	RATCHET
5	2	QUARTER PANEL CLOSEOUT PANEL (1 DRIVER, 1 PASSENGER)	TORQUE WRENCH
6	2	LIGHTED SCREW	ALLEN WRENCH
7	4	M6 SPLIT LOCK WASHER	DRILL MOTOR
8	2	M8 SERRATED FLANGE NUT	1/2" DRILL BIT
9	4	M6 HEX NUT	15MM SOCKET
10	8	M14 HEX HEAD CAP SCREW	HEAT GUN
11	8	M14 FLAT WASHER	21MM SOCKET
12	8	M14 SPLIT LOCK WASHER	
13	4	M4 HEX SOCKET BUTTON HEAD SCREW	
14	4	M4 FLAT WASHER	
15	4	M4 SPLIT LOCK WASHER	
16	4	M4 HEX NUT	
17	12	M6 FLAT WASHER	
18	4	M6 HEX SOCKET BUTTON HEAD BOLT	
19	2	M8 SQUARE NECK CARRIAGE BOLT	

ANTI-SEIZE LUBRICANT MUST BE USED ON ALL STAINLESS STEEL FASTENERS TO PREVENT THREAD DAMAGE AND GALLING

PROCEDURE

1. Remove contents from box, verify if all parts listed are present and free from damage.
Carefully read and understand all instructions before attempting installation.
Failure to identify damage before installation could lead to a rejection of any claim.



20	4	M6 SERRATED FLANGE NUT	
21	4	M6 HEX HEAD CAP SCREW	
22	4	PARKING SENSOR FOAM GASKET	
23	4	SENSOR TAB	

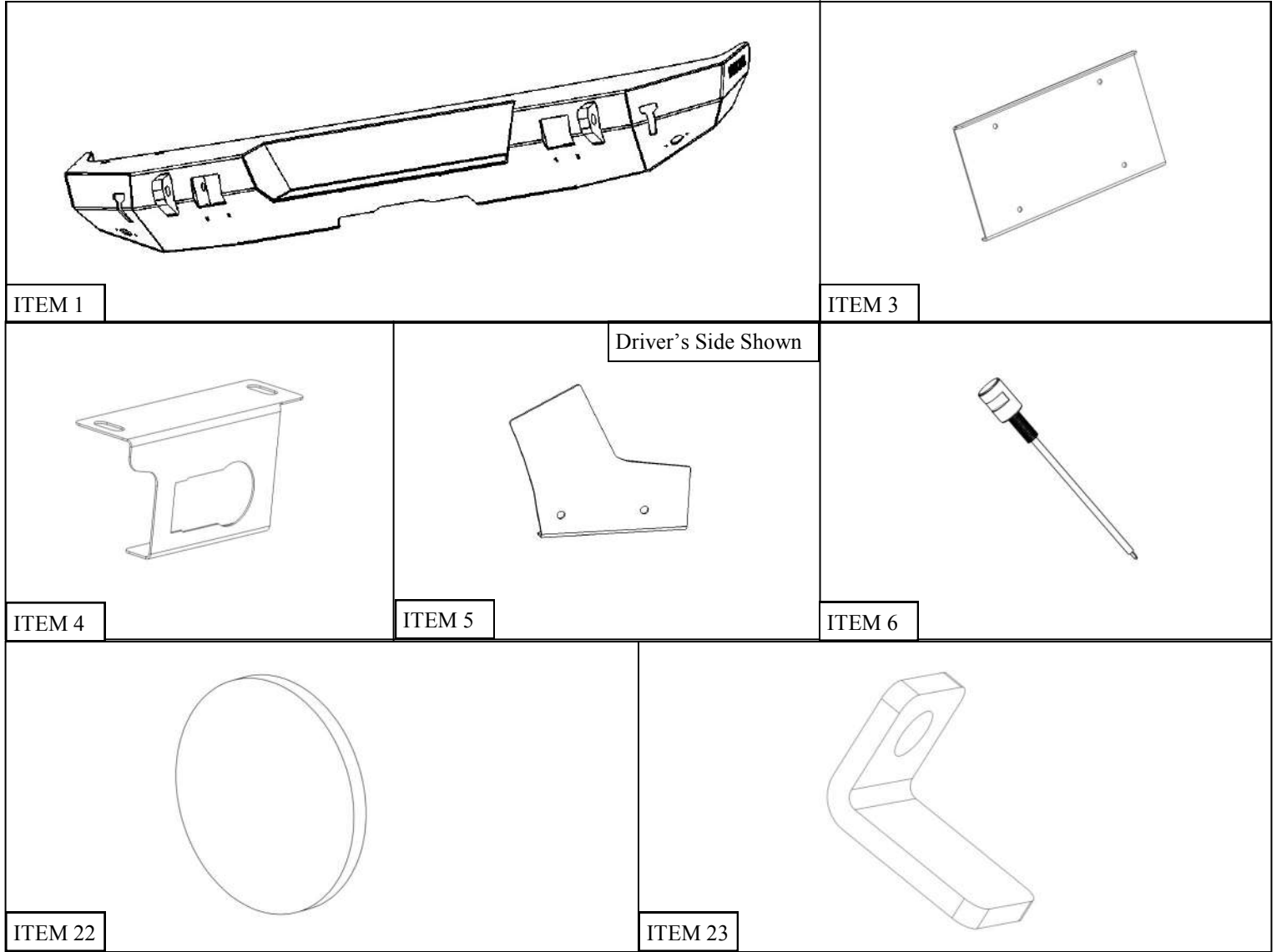

2. Begin by removing the 3 bolts securing the plastic trim on either side. **See Figure 1.**
3. Remove the bolts holding the bumper and recovery hook (if equipped) on both sides. **See Figures 2 & 3.** *Note: Recovery Hook cannot be reused.*



4. Disconnect the four sensors from their connections to the wire harness. Leave the sensor pods themselves in the OE bumper at this time.

5. Remove the bolt securing the support bracket on either side along either the bolts securing the bracket to the frame and bumper. See **Figure 4**.



6. Using a 16mm socket, remove the bottom two bumper bolts and the two trailer plug bracket bolts (if equipped). See **Figure 5**.

7. Carefully Remove the OEM Bumper.



PARKING SENSOR INSTALLATION

8. Remove the four parking sensors from the OEM bumper. Pay attention to the orientation of the sensors. They must be installed in the same orientation. Handle sensors with care, they are very delicate .
9. Use the Sensor Tab (23), the Foam Gasket (22) (between tab and sensor), and the supplied M6 Hardware (17, 20, 21) to install the sensors in the four locations as shown in **Figure 6-8**.
10. Carefully route the harness around the bumper.

Note: Zip ties or double sided tape can be used to route harness and to hold the sensor in position.

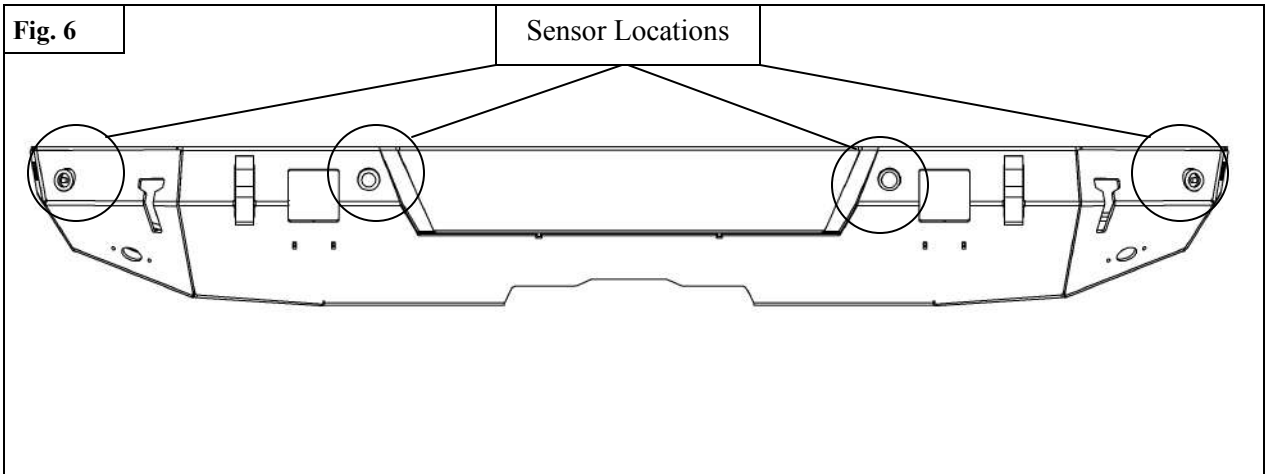

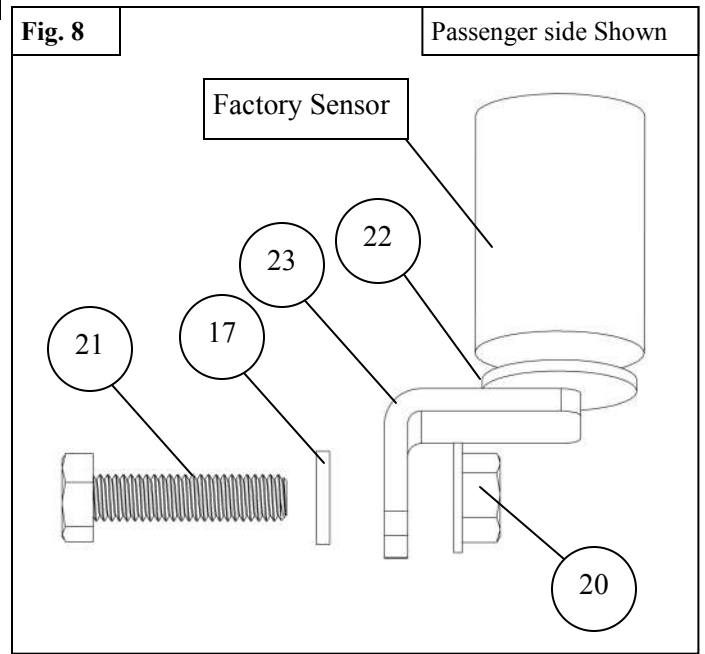
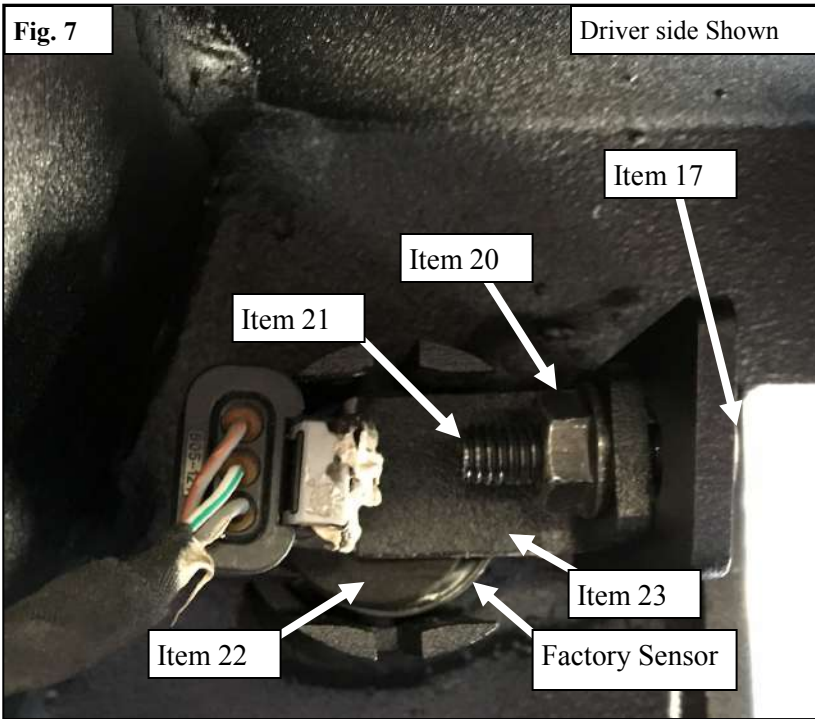

OPTIONAL STEP

7. Back up Lights can be installed in the two specified middle locations of the bumper. Install lights per manufacturers instructions. Install through the back side of the bumper. **See Figure 9.** *Note: It is recommended to install the lights in the bumper prior to mounting the bumper on the vehicle.*

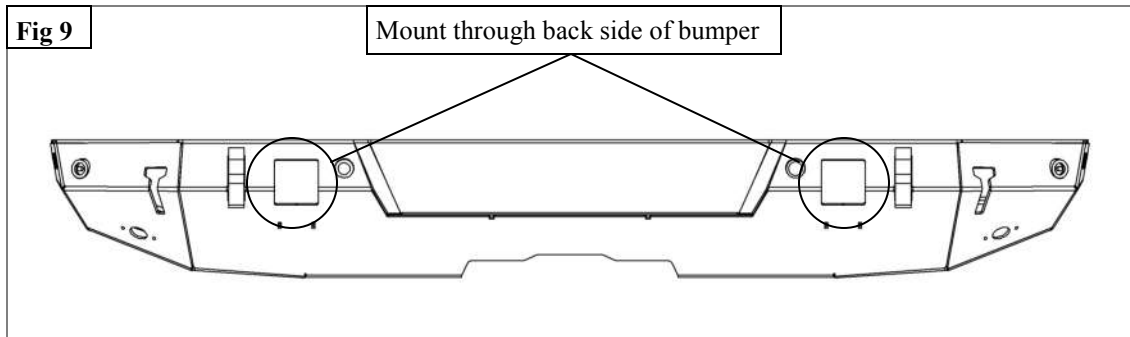

12. Slide the M14 Nut Plate (2) into the frame. Lift the WJ2 Rear Bumper Assembly (1) onto the frame rails. **See Figure 10.**
 13. Using the supplied M14 Hardware (10-12) loosely install the bumper to the frame in the same bolt locations as the OEM bumper. **See Figure 11.**

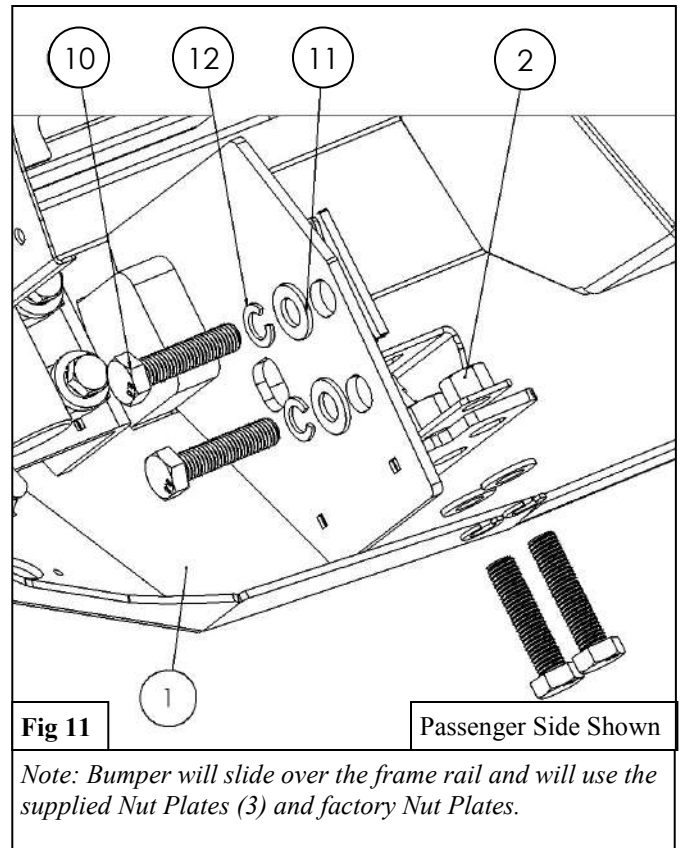
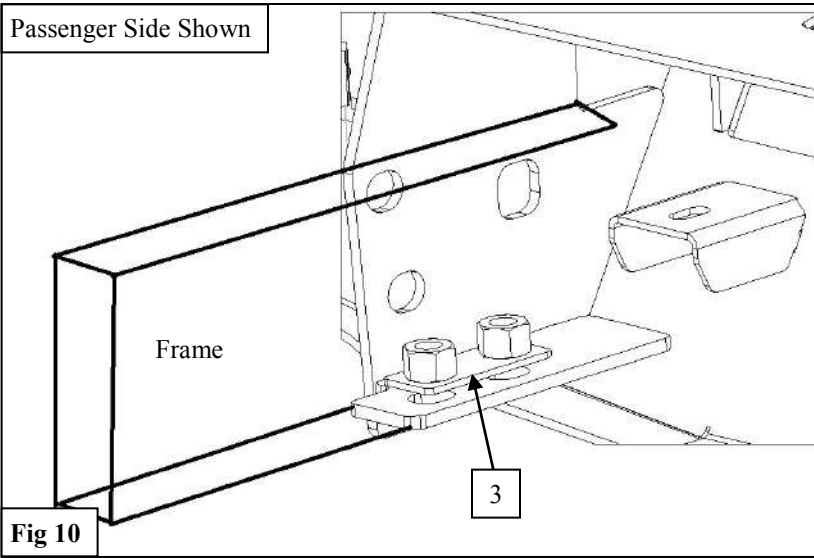

OPTIONAL STEP:

Rock Lights (sold separately) can be installed in the lower corners of the bumper using the supplied M4 hardware.
Note: Install lights per manufacturers instructions. See **Figure 12**.

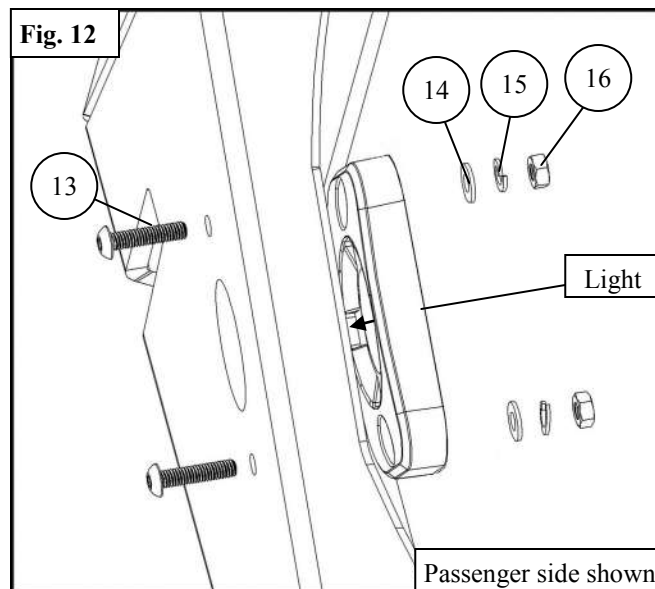

14. Next, install the License Plate Relocation Bracket (3) using the supplied M8 Hardware. **See Figure 13.**
15. **Optional Step:** The Trailer Plug Relocator Bracket may be installed for easier access to the trailer plug. It mounts in the stock location using the factory hardware.
- Note: The Lighted Screws (6) will attach in the top two holes of the License Plate Relocator (3). Use the factory license plate light harness to wire the Lighted Screws (6). Do so by using the supplied crimp connectors to splice the Lighted screw (6) wires into the factory harness. Make sure to seal them using a heat gun afterwards.*

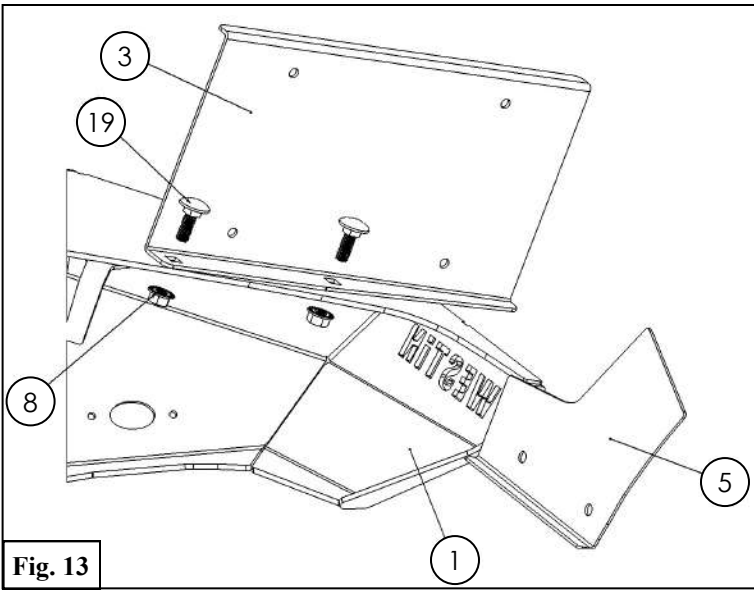

Fig. 13

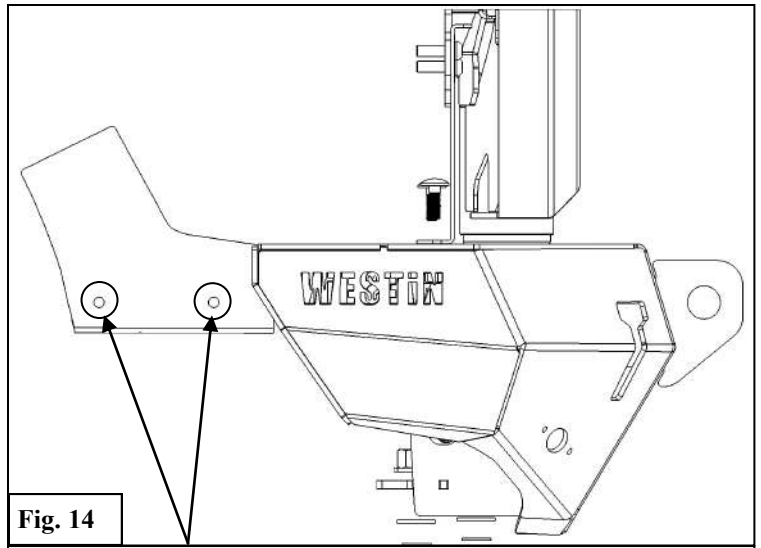

Fig. 14

Align the panel to the desired fit. Drill out the indicated holes.

OPTIONAL STEP

16. Installation of the Quarter Panel Closeout Panels (5) will use the supplied M6 Hardware. For installation, align the Closeout Panel with the WJ2 Rear Bumper as shown in **Figure 14**.
17. Once the panel is positioned, mark and drill the two mounting holes using a 1/4" drill bit. Then, install with the M6 Hardware. **See Figures 14-16.**

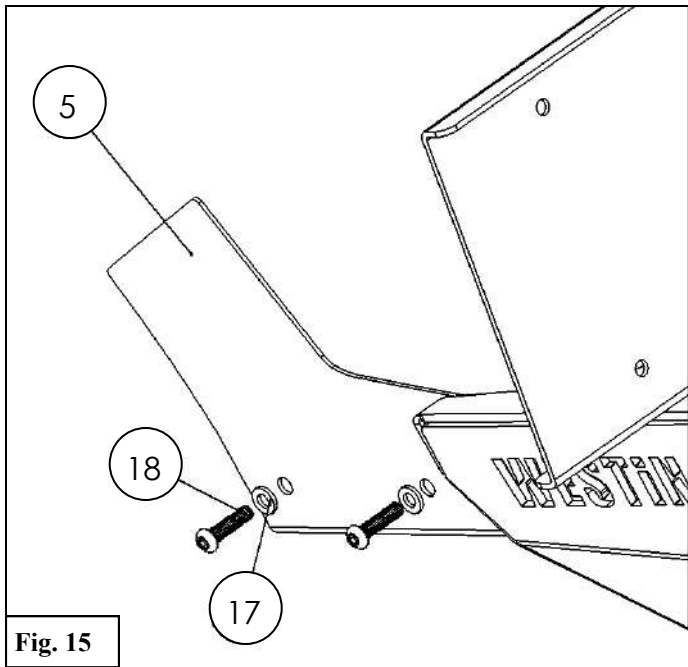

Fig. 15

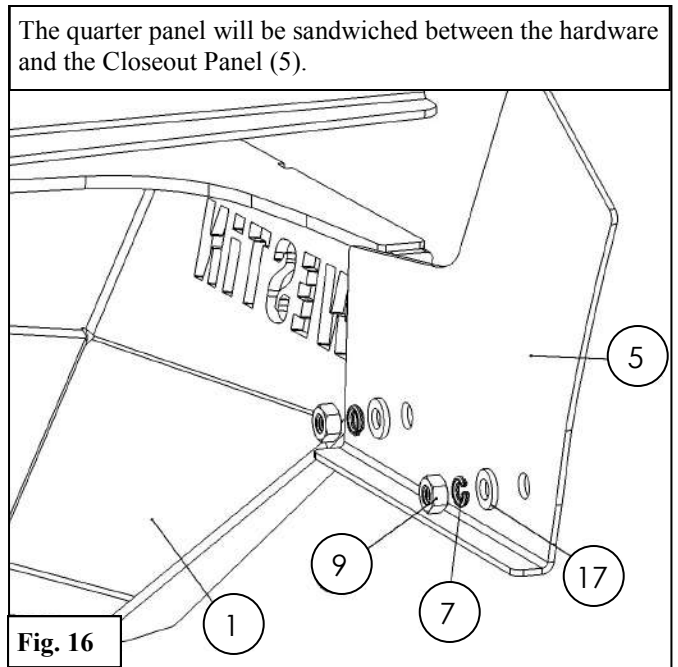

Fig. 16

The quarter panel will be sandwiched between the hardware and the Closeout Panel (5).

18. Adjust bumper as necessary and torque down all hardware to specified ft-lbs: M4 to 2 ft-lbs, M6 to 7 ft-lbs, M8 to 18 ft-lbs, M14 to 100 ft-lbs.

INSTALLATION COMPLETE



Lights sold separately



© 2014 WESTIN, INC. ALL RIGHTS RESERVED

WESTIN

PART TWO: WJ2 TIRE CARRIER INSTALLATION ONLY

ITEM	QUANTITY	DESCRIPTION	TOOLS NEEDED
1	1	TIRE CARRIER ASSEMBLY	18MM SOCKET
2	1	SPINDLE	18MM WRENCH
3	1	BEARING KIT	36MM SOCKET
4	1	TAILGATE MOUNT	10MM WRENCH
5	1	TIRE MOUNT ASSEMBLY	RATCHET
6	1	RUBBER BUMPER BRACKET	TORQUE WRENCH
7	2	RUBBER BUMPER	ALLEN WRENCH
8	2	TURN BUCKLE ASSEMBLY	15MM SOCKET
9	1	BEARING CAP	TORX BIT
10	1	CHMSL LIGHT RELOCATOR	
11	1	CAMERA MOUNTING AND EXTENSION BRACKET	
12	9	M6 FLAT WASHER	
13	3	M3 PHILLIPS HEAD SCREW	
14	4	M12 HEX SOCKET BUTTON HEAD SCREW	
15	8	M8 HEX SOCKET BUTTON HEAD BOLT	
16	16	M12 FLAT WASHER	
17	6	M12 SPLIT LOCK WASHER	
18	6	M12 HEX NUT	
19	8	M8 SPLIT LOCK WASHER	
20	8	M8 FLAT WASHER	
21	6	M12 HEX HEAD CAP SCREWS (2x 20mm, 2x 80mm, 2x 90mm)	
22	1	M4 PAN HEAD PHILLIPS SCREW	
23	2	M12 NYLOCK NUT	
24	4	M6 NYLOCK NUT	
25	4	M6 HEX SOCKET HEAD SCREW	
26	2	M10 SERRATED FLANGE NUT	
27	2	M10 SERRATED FLANGE BOLT	
28	1	M24 CASTLE NUT	
29	1	M8 SET SCREW	
30	4	SPINDLE SHIM	
31	1	4MM SQUARE KEYSTOCK	
32	4	M12 CLASS 10.9 HEX HEAD CAP SCREW	
33	4	M12 HEAVY FLAT WASHER 5MM THICK	

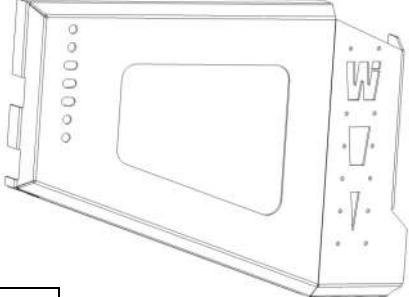
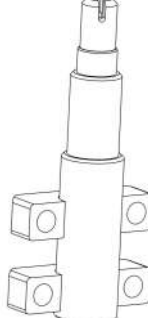
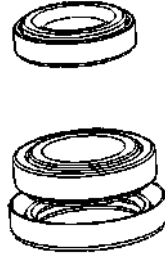
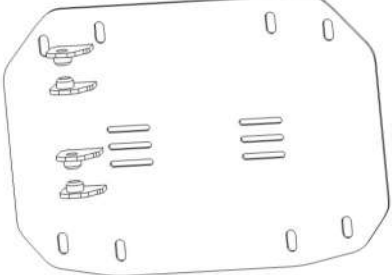
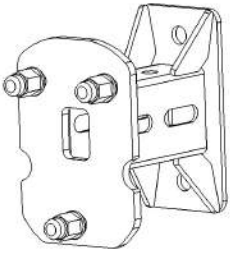
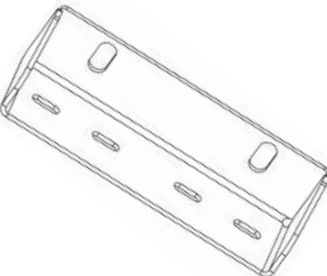
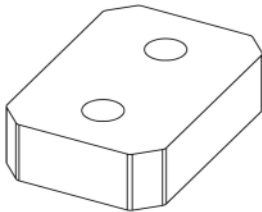
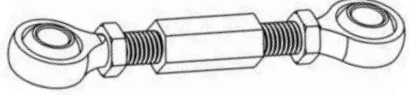
ITEM	QUANTITY	DESCRIPTION	TOOLS NEEDED
34	4	M12 HARDENED SPLIT LOCK WASHER	
35	1	CORRUGATED SLEEVE	
36	1	M6 SPLIT LOCK WASHER	
37	1	M6 BUTTON HEAD SCREW	
38	2	M10 HEX HEAD BOLT	

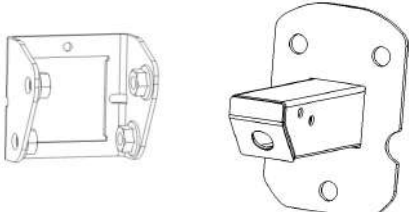
 <p>ITEM 1</p>	 <p>ITEM 2</p>	 <p>ITEM 3</p>
 <p>ITEM 4</p>	 <p>ITEM 5</p>	 <p>ITEM 6</p>
 <p>ITEM 7</p>	 <p>ITEM 8</p>	 <p>ITEM 10</p>
 <p>ITEM 11</p>		

Tire Carrier Installation (59-82035 only)

1. Use a T40 bit to remove the lock from the camera. See **Figure 1**.
2. Remove the spare tire at this time.
3. Remove all bolts to the factory tire carrier. See **Figure 2**.



Fig. 1

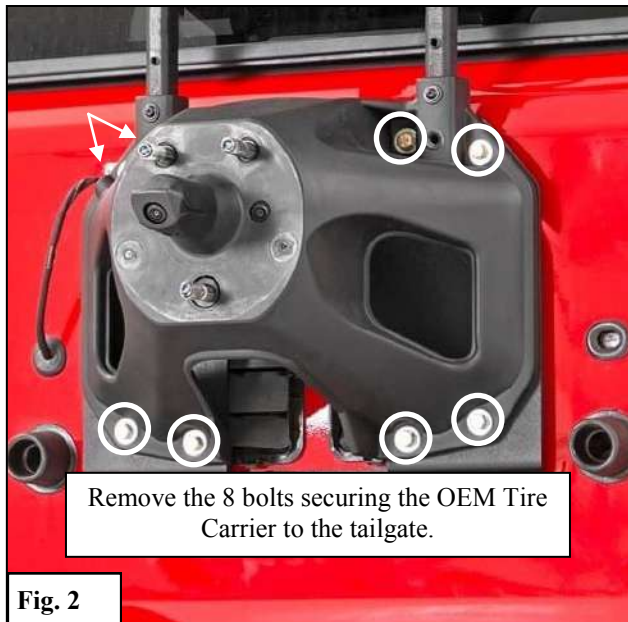

Remove the 8 bolts securing the OEM Tire Carrier to the tailgate.

Fig. 2

4. After removing the Tire Carrier, trace back the wiring for the brake light and rear camera. Pry off the inside tailgate trim to access the inside of the tailgate. See **Figure 3**.
5. From the inside of the tailgate, pry out the inner vent. See **Figure 4**.
6. Unplug both the camera and brake light wiring and remove them from the carrier and set aside. See **Figure 5**.



Fig. 3

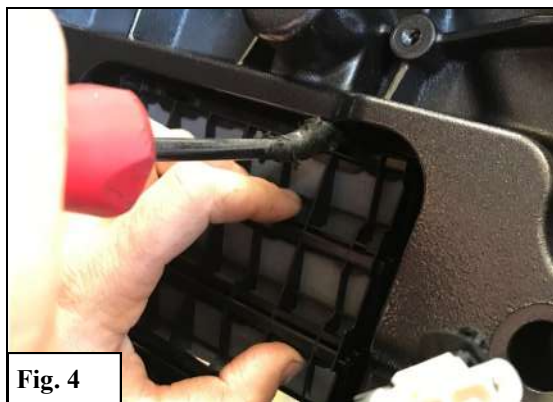

Fig. 4

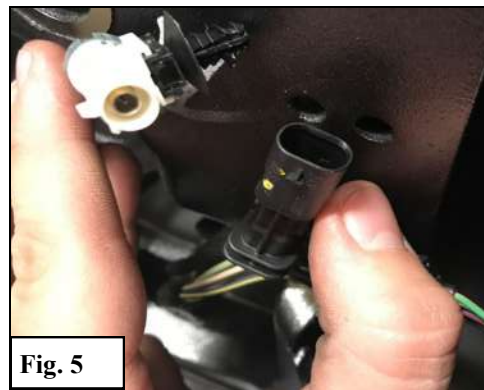
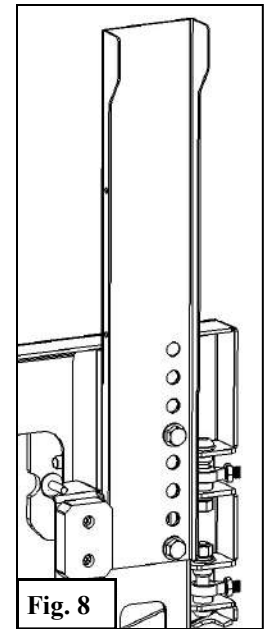
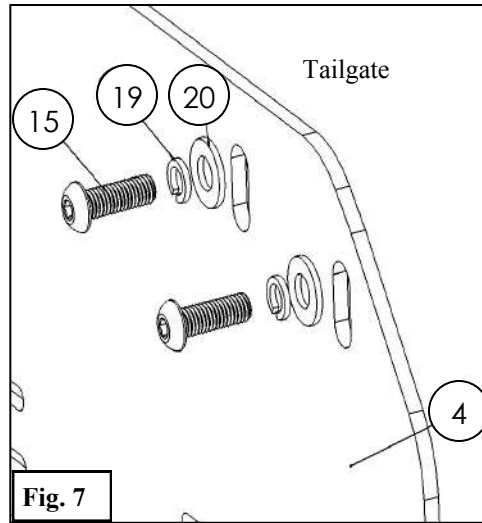
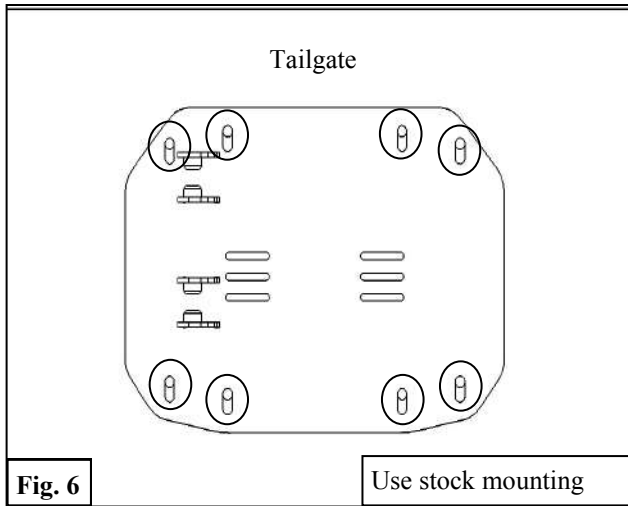
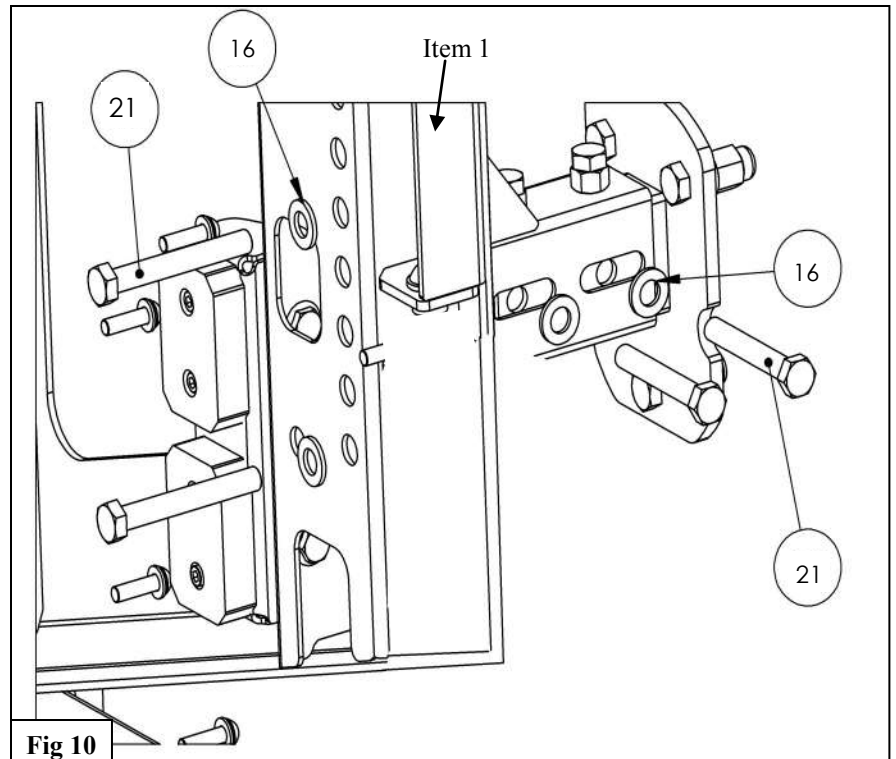
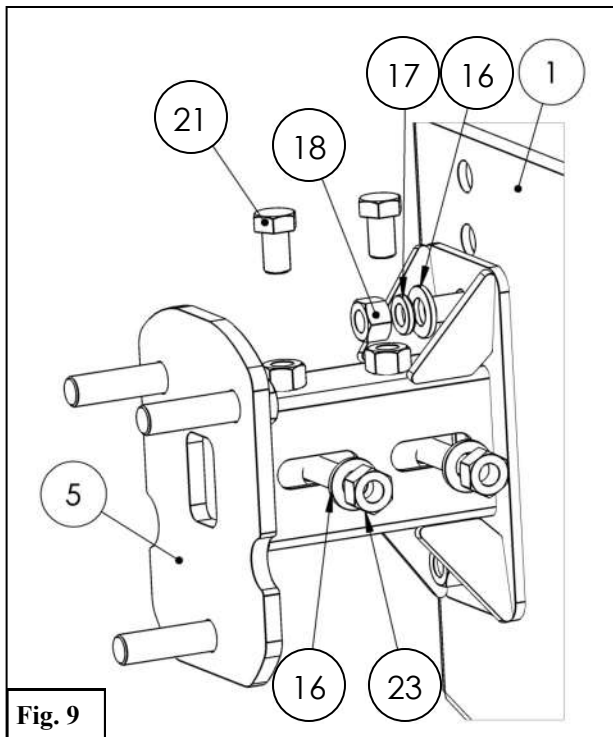

Fig. 5

7. The Tailgate Mount (4) will attach to the tailgate using the factory tire carrier mounting holes. See **Figure 6**.
8. Install the Tailgate Mount (4) using the supplied M8 Hardware. See **Figure 7**.



9. Install the Tire Mount (5) to the Tire Carrier (1) along with the CHMSL Light Relocator (10) using the supplied M12 Hardware. See **Figures 8-10**.



10. Install the spindle (2) onto the bumper using the supplied M12 Hardware. Insert the M10 Spindle Adjustment Hardware. See Figure 11-12. *Note— do not fully tighten at this time.* **Important: Use the Class 10.9 Hardware & thick washers to mount the spindle. Use two spindle shims (30) as a base adjustment.**

IT IS IMPORTANT TO USE THE CLASS 10.9 HARDWARE & THICK WASHERS

Class 10.9

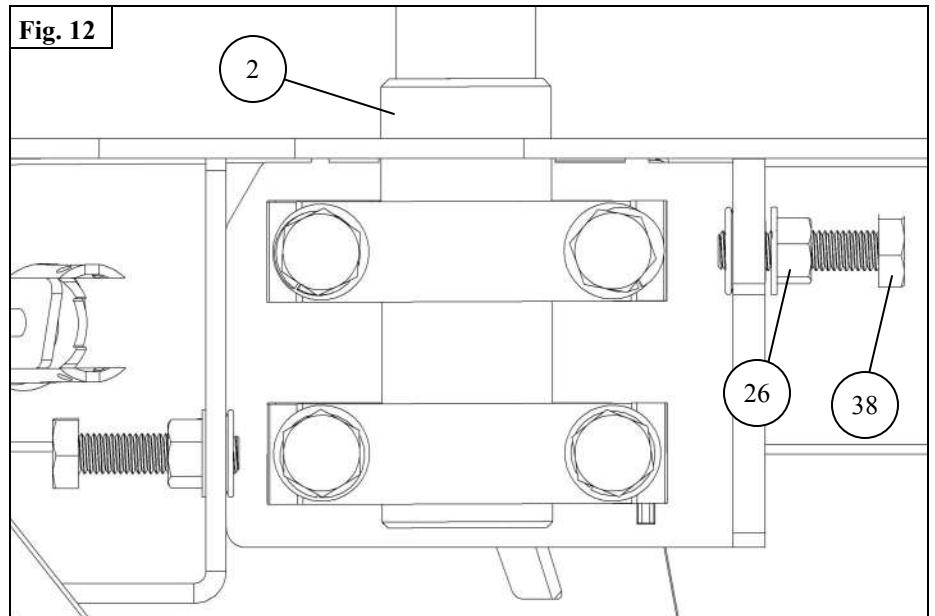
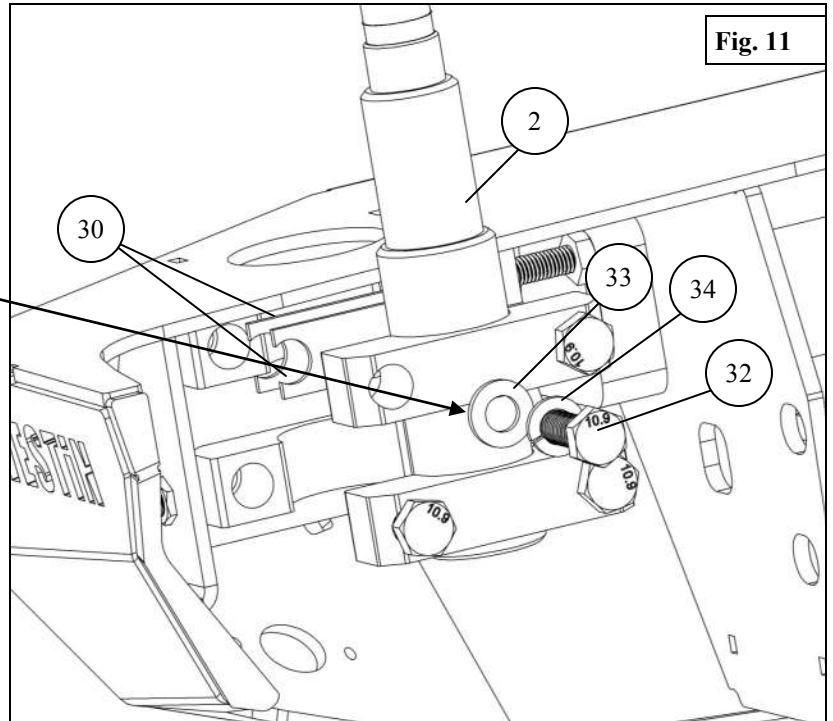

10. Bearing Installation

NOTE: BEARINGS MUST BE PACKED WITH GREASE FOR PROPER FUNCTION AND LONGEVITY

- A. Obtain the Bearing Kit (3).
- B. Identify the large bearing, race, and seal.
- C. Turn the Tire Carrier over so that the bottom of the spindle tube is facing up.
- D. Insert the bearing race into the tube with the tapered side facing up. **See Figure 13.**
- E. Place a generous amount of grease (not included) in the palm of your hand, and tap the bearing repeatedly in the grease until grease is spread throughout the rollers in the bearing.
- F. Place the bearing into the race as oriented in **Figure 13.**
- G. Place the large bearing washer on top of the bearing. **See Figure 13.**
- H. Using a soft hammer, tap the seal into place until flush with the bottom of the spindle tube on the tire carrier. **See Figure 13.**
- I. Repeat steps B-G for the small bearing with the tire carrier turned right side up.

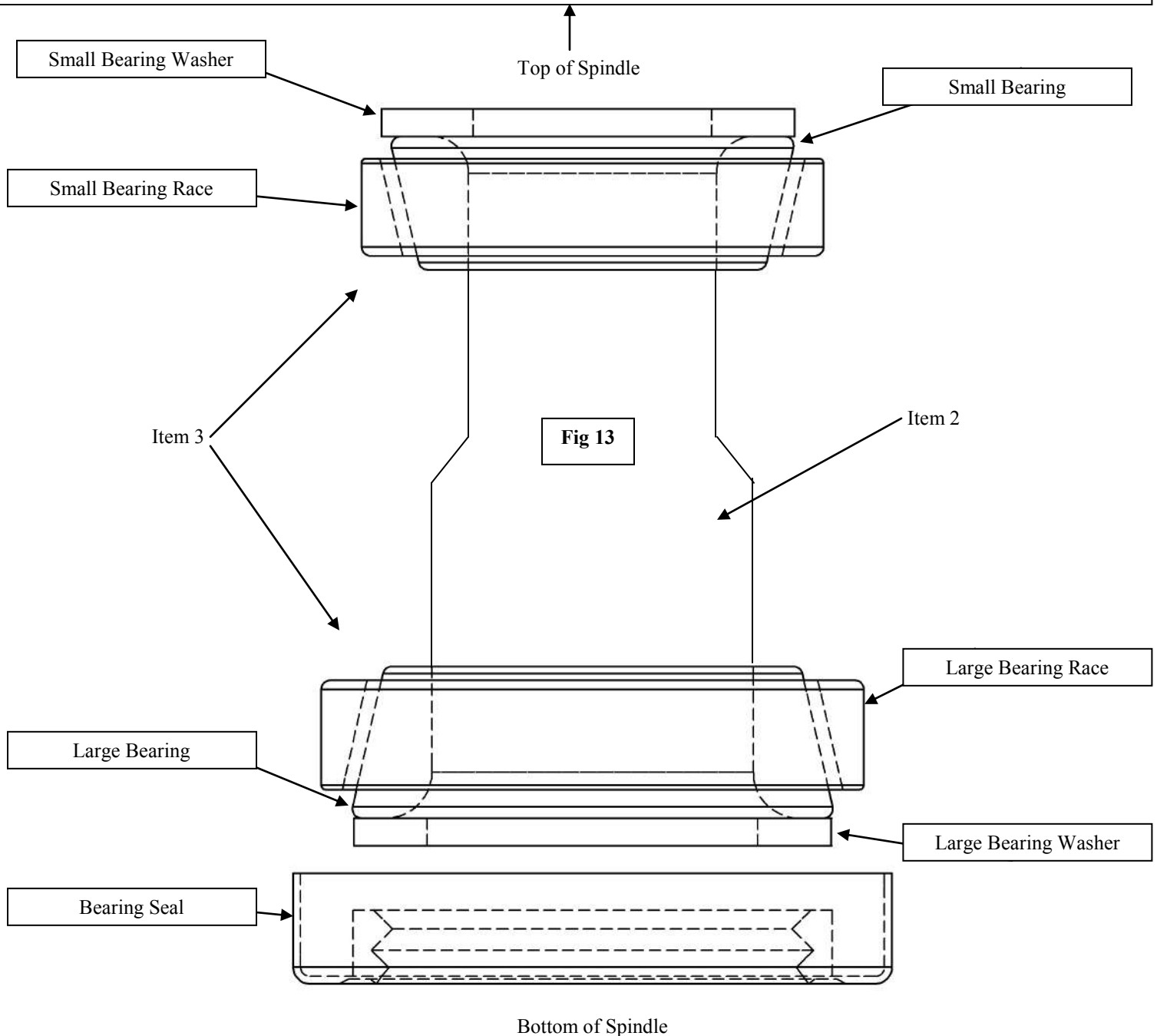

11. Install the Rubber Bumper (7) to the Rubber Bumper Bracket (6) using the supplied M6 Hardware. See Figures 14 and 15.
12. Install the Rubber Bumper Assembly to the Tire Carrier (1) using the supplied M10 Hardware. See Figures 15 and 16.

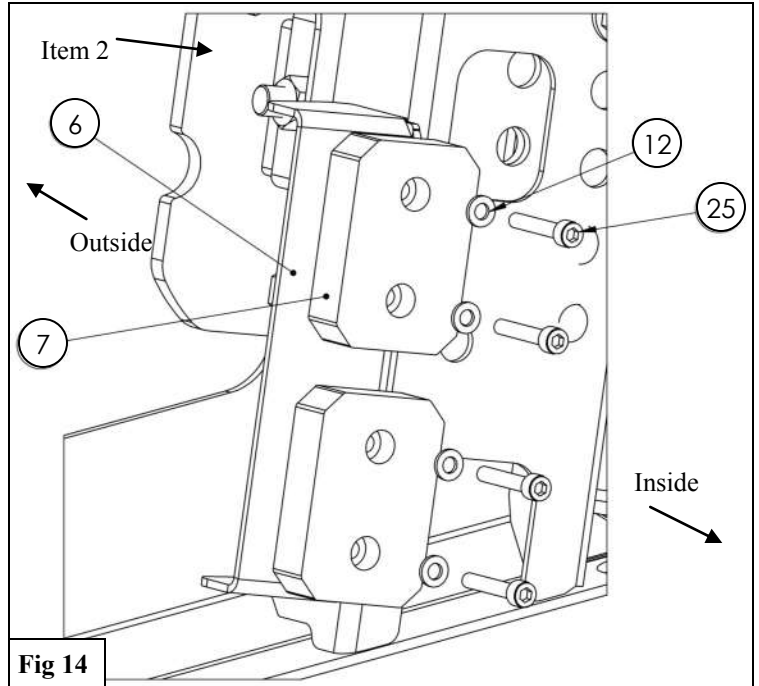
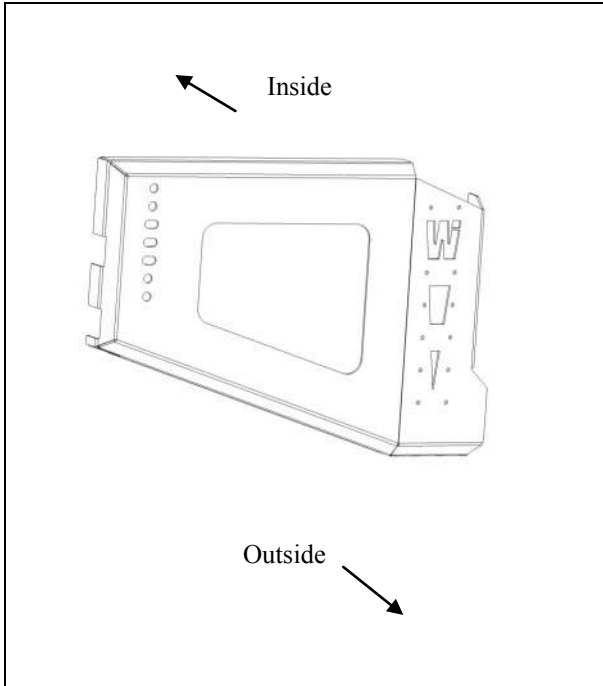

Fig 14

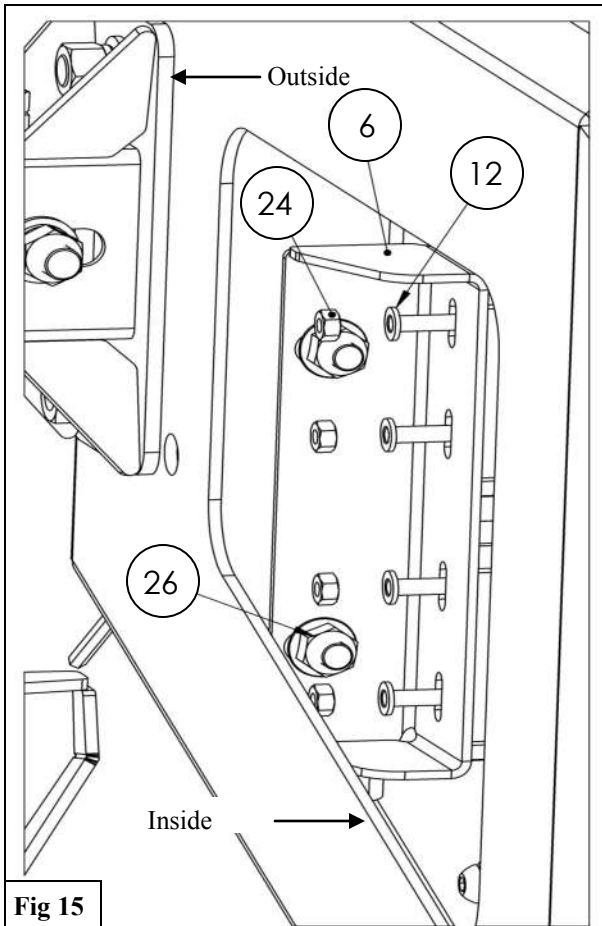

Fig 15

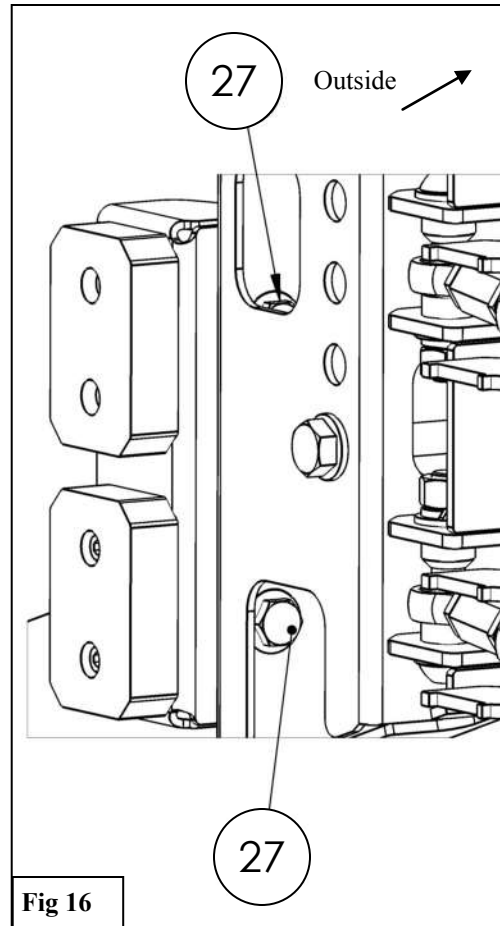
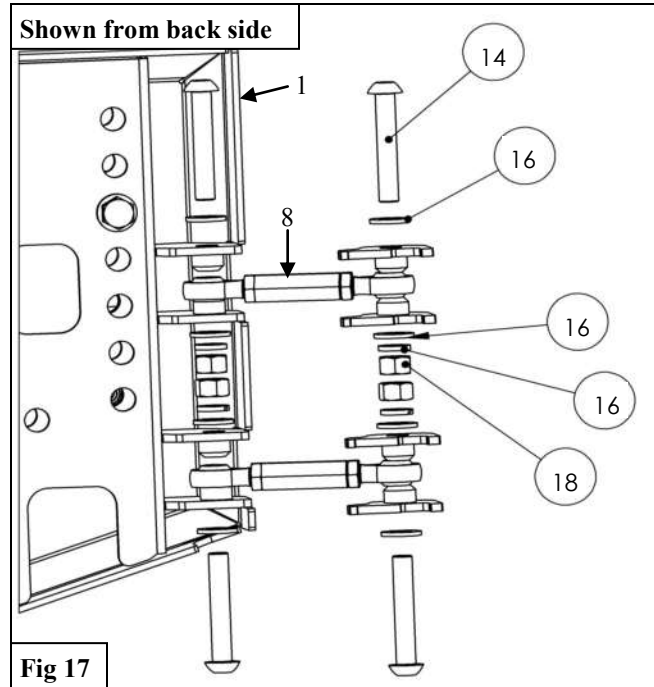
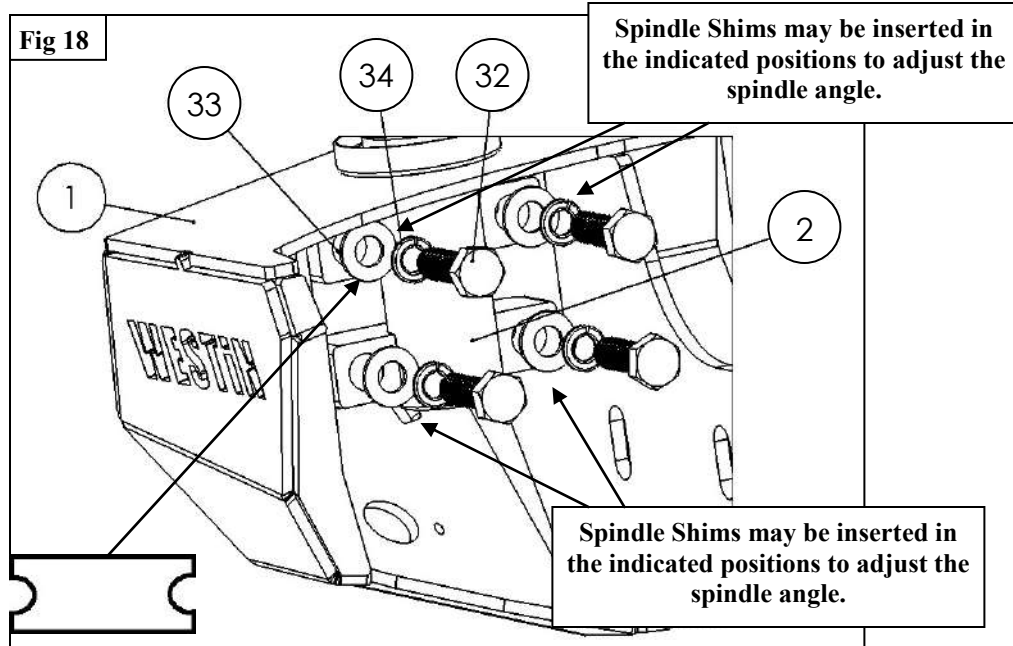

Fig 16

13. Lift the Tire Carrier Assembly and carefully slide it onto the Spindle (2).
14. Install the M24 Castle Nut (28) onto the Spindle (2). You may now tighten the Castle Nut (28) just until tension is felt. Then, place the 4mm Keystock (31) in the slot on the Castle Nut (28) and Spindle (2).
15. Loosely install the Turn Buckles (8) at this time. **See Figure 17.**
16. Adjust the Tire Carrier so that it sits just above level with the tub of the vehicle. With help, torque the M12 Spindle hardware to **75-78 ft-lb.** *Note: If the tire carrier is not vertical, use a combination of the supplied Spindle Shims (30) and tightening the M10 Spindle Adjustment (38) Bolts to change the angle of the spindle with the tub of the vehicle. See Figure 17-18.*



17. Tighten the Turn Buckles (8) until the Rubber Bumpers (7) come in contact with the Tailgate Mount (4). *Note— some trimming of the Rubber Bumpers may be required if they contact the bolts on the Tailgate Mount.*
18. Tighten the jam nuts on the Turn Buckles (8).
19. Secure the Castle Nut (28) with the supplied M8 Set Screw (29). **See Figure 19.**



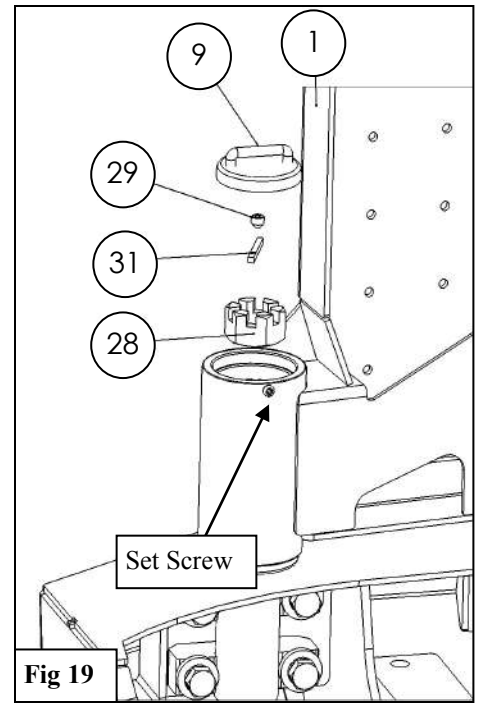
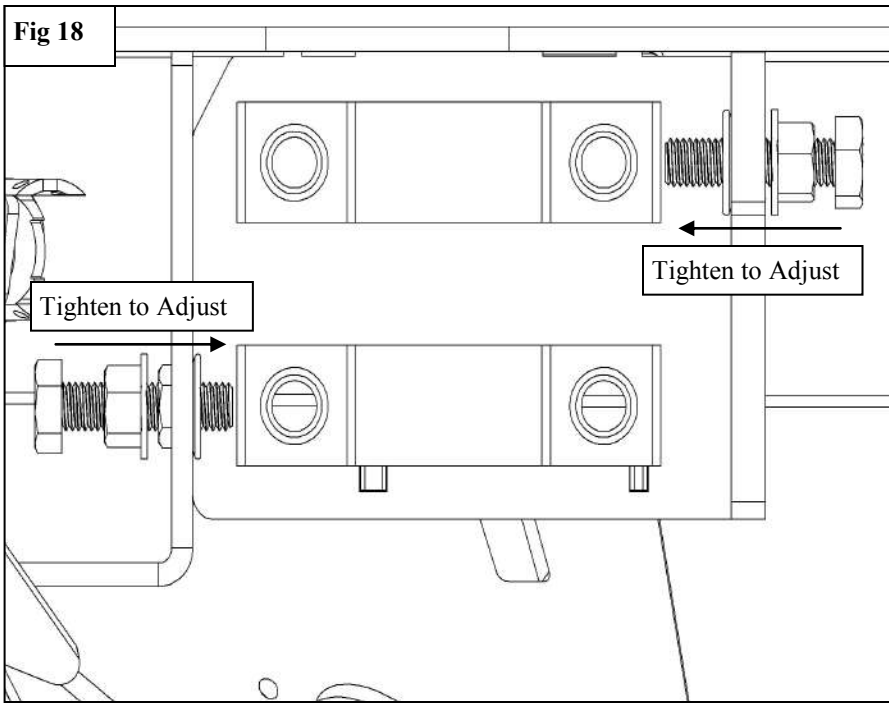

20. Before mounting the rear view camera, use the supplied Corrugated Sleeve (36) to wrap the areas of the wire inside the tire carrier. *Note: The wire can be fed through the access hole in the Tire Carrier (1). See Figure 20.*
21. Obtain the Camera Mounting Bracket (11) and attach the camera using the supplied M3 Screws (13). **See Figure 21.**
22. Slide the camera into the Camera Extension Bracket (11) and secure it using the supplied M6 Hardware. **See Figure 22.**
Note: There is a small amount of adjustment for the camera by loosening the bolts and adjusting using the access hole on the underside of the Extension (11).
23. **DRIVE THE VEHICLE FOR 50-75 MILES. THEN READJUST TURN-BUCKLES AND RE-TORQUE MOUNTING HARDWARE.**

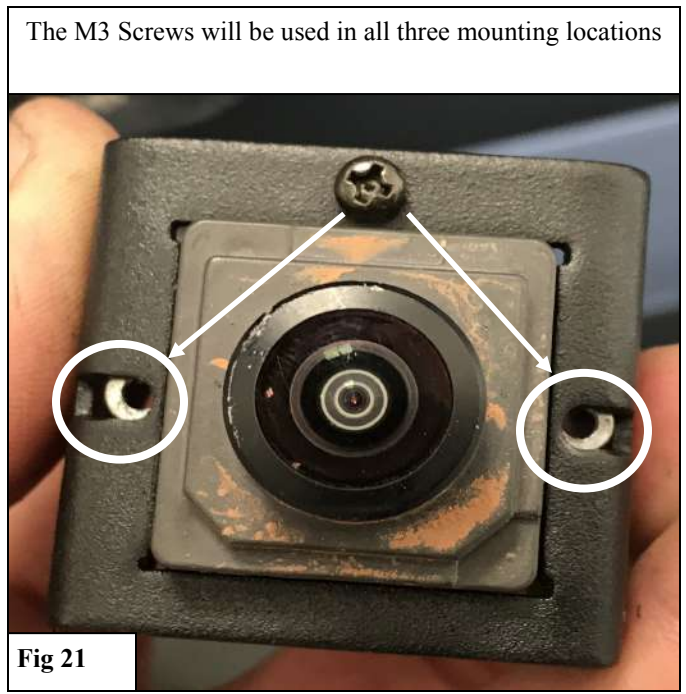
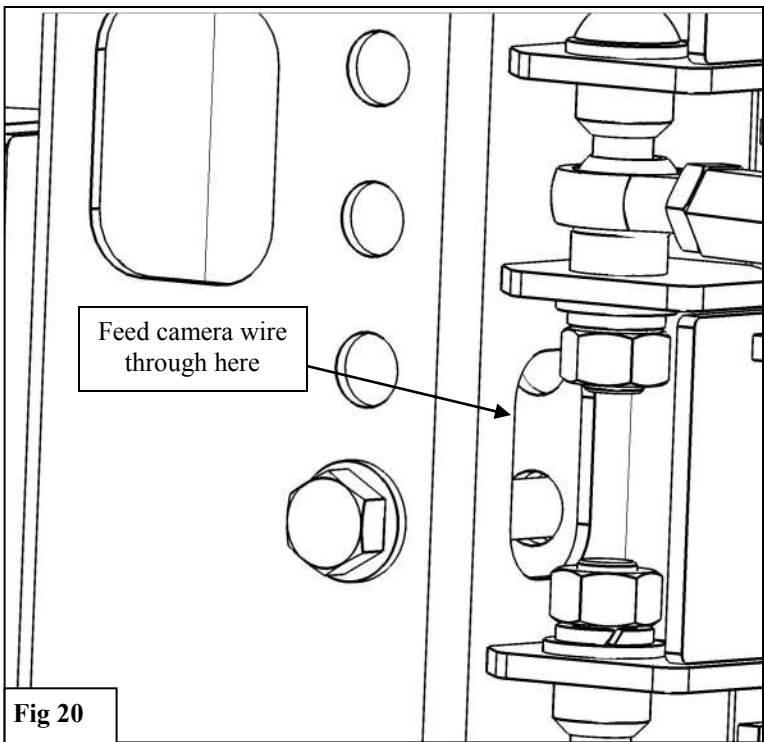

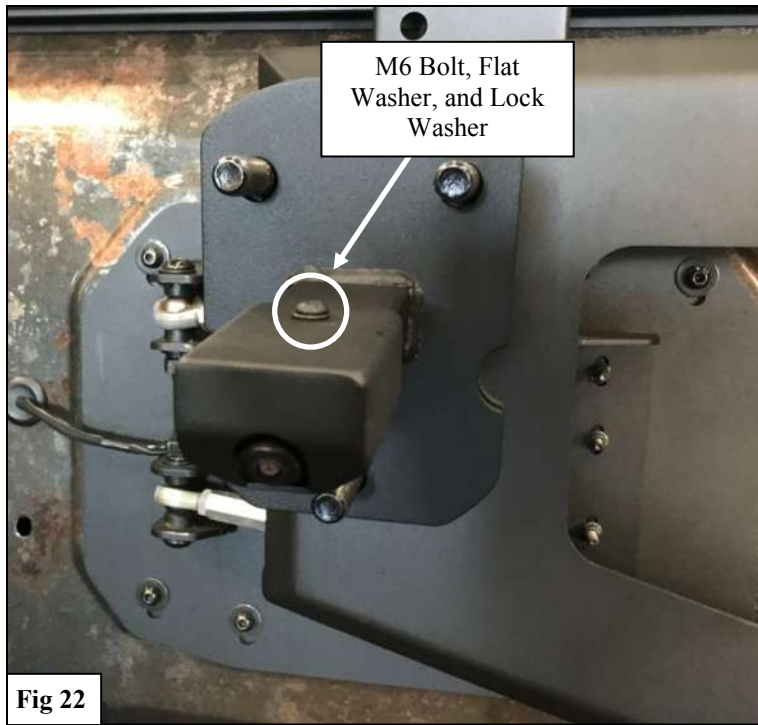

Fig 22



Fig 23

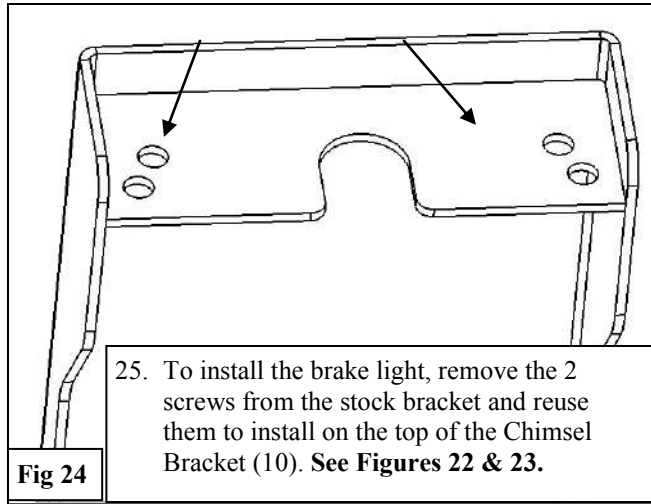

Fig 24

25. To install the brake light, remove the 2 screws from the stock bracket and reuse them to install on the top of the Chimsel Bracket (10). See Figures 22 & 23.

24. Adjust bumper as necessary and torque down all hardware to specified ft-lbs: M6 to 7 ft-lbs, M8 to 18 ft-lbs, M10 to 35 ft-lbs, M12 CLASS 8.8 to 55-60 ft-lbs, M12 CLASS 10.9 to 75-78 ft-lbs

INSTALLATION COMPLETE



©2018 WESTIN AUTOMOTIVE PRODUCTS, INC. ALL RIGHTS RESERVED

CARE INSTRUCTIONS.

- TEXTURED BLACK PRODUCT MAY BE CLEANED USING MILD SOAP AND WATER.
- STAINLESS STEEL PRODUCTS CAN BE CLEANED WITH MILD SOAP AND WATER. STAINLESS STEEL POLISH SHOULD BE USED TO POLISH SMALL SCRATCHES.
- GLOSS BLACK FINISHES SHOULD BE CLEANED WITH MILD SOAP AND WATER

WESTIN



WARNING



Failure to follow these instructions could lead to death, personal injury, and / or property damage.

Failure to follow these instructions could lead to death, personal injury, and / or property damage.

FASTENERS:

All Westin supplied fasteners must be utilized and installed in accordance with the installation instructions and apply torque to the specifications as defined. **DOUBLE CHECK ALL FASTENERS BEFORE INITIAL USE, AND PERIODICALLY IN THE FUTURE TO ENSURE PROPER FUNCTION AND SAFETY.**

DRILLING:

Most Westin products do not require drilling for installation. If drilling is defined as required, use caution when drilling a vehicle. **FAILURE TO REVIEW AN AREA TO BE DRILLED MAY RESULT IN PERSONAL INJURY AND/OR INJURY TO OTHERS AS WELL AS VEHICLE DAMAGE.**

EYE PROTECTION:

ALWAYS WEAR SAFETY GLASSES OR GOGGLES DURING THE INSTALLATION PROCESS TO AVOID PERSONAL INJURY.

MAXIMUM TOWING/CARRYING CAPACITY: (if applicable)

The Westin Receiver Hitches will have a visible tow rating label affixed directly on the product. User should never exceed the vehicle manufacturers maximum tow and weight rating regardless of the capacity of the hitch. **FAILURE TO FOLLOW THESE GUIDELINES WILL VOID THE WESTIN WARRANTY AND MAY RESULT IN PERSONAL INJURY AND/OR INJURY TO OTHERS AS WELL AS VEHICLE DAMAGE.**

FOR CALIFORNIA RESIDENTS ONLY-PROP 65 WARNING:

Some products may contain chemicals such as DEHP, which can cause cancer, birth defects or other reproductive harm.

