



Important Notice - Read This First

Before any tear-down or disassembly begins, review the following information:

- For 1971-1972 C10 applications - this spindle kit requires later model 1973-1987 C10 upper and lower ball joints, and tie rod ends, not included.
- Due to OEM production differences and other variations from vehicle to vehicle, the fastener hardware and other components in this kit may not be suitable for a specific application or vehicle.
- It is the responsibility of the purchaser and installer of this kit to verify suitability / fitment of all components and ensure all fasteners and hardware achieve complete and proper engagement. Improper or inadequate engagement can lead to component failure.

Photographic Tip

Important and highly recommended: Take photos of brake system before disassembly and during the disassembly process. In the event, trouble-shooting photos can be life savers. Many vehicles have undocumented variations, photos will make it much simpler for Wilwood to assist you if you have a problem.

Exploded Assembly Diagram

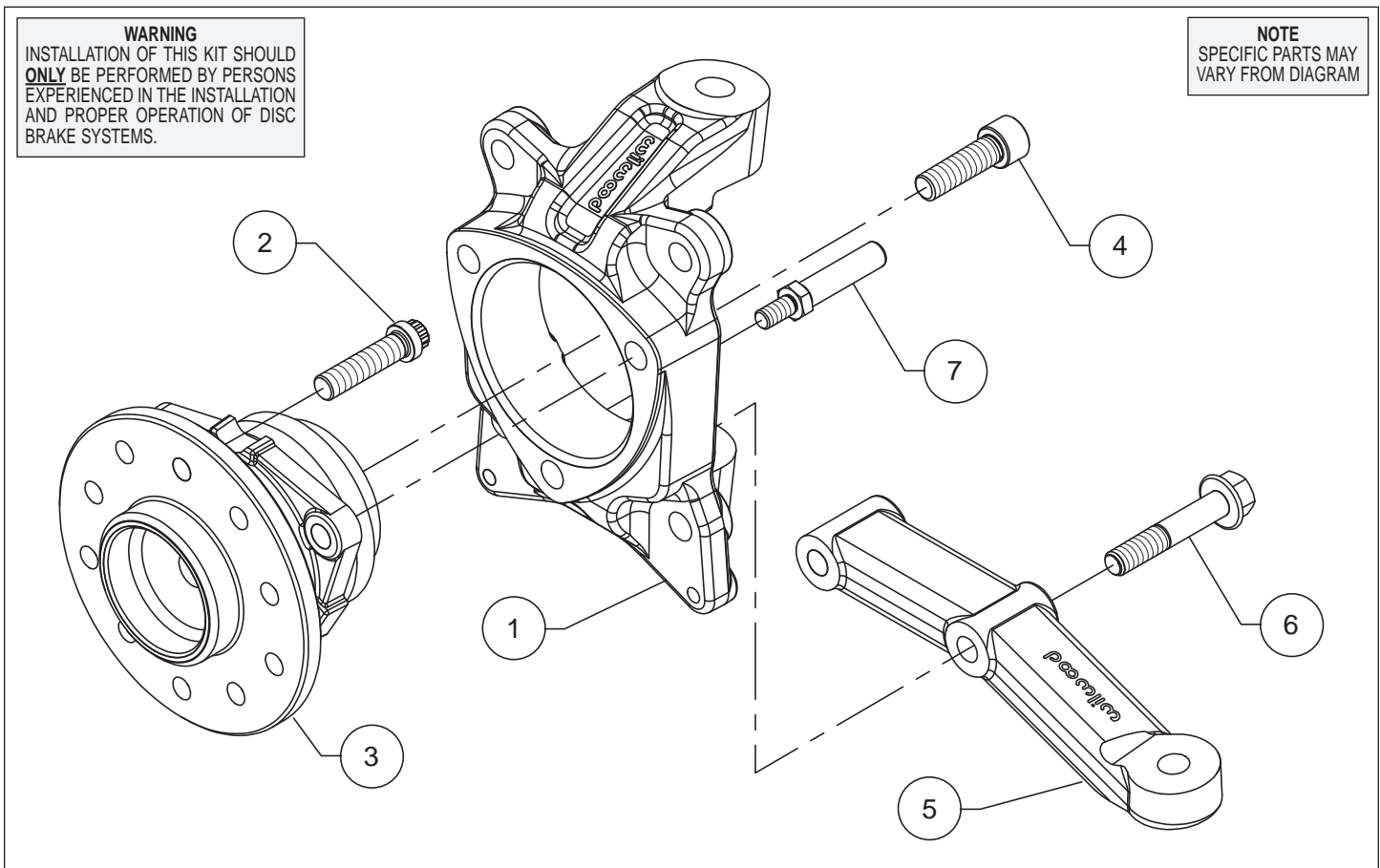

Parts List

| <u>ITEM NO.</u> | <u>PART NO.</u> | <u>DESCRIPTION</u> | <u>QTY</u> |
|-----------------|-----------------|--|------------|
| 1 | 810-14122 | Spindle, 2.50 Drop | 2 |
| 2 | 230-6959 | Bolt, 1/2-20 x 2.00 Long, 12 Point | 10 |
| 3 | 270-15104 | Hub Assembly | 2 |
| 4 | 230-14197 | Bolt, M14-1.5 x 45mm Long, Socket Head | 6 |
| 5 | 819-14127/28 | Steering Arm, Right/Left | 2 |
| 6 | 230-14196 | Bolt, 1/2-13 x 2.75 Long, Hex Head | 4 |
| 7 | 230-14167 | Stud, Steering Stop, 3/8-16 x 3.00 Long, Hex | 2 |

NOTES:

Part Number 230-14198 Bolt Kit, steering arm to spindle, includes part numbers 230-14167 and 230-14196

Part Number 230-14199 Bolt Kit, hub to spindle, includes part number 230-14197

Part Number 230-14200 Bolt Kit, wheel studs, includes part number 230-6959

General Information and Disassembly Instructions

- Installation of this kit should **ONLY** be performed by persons experienced in the installation and proper operation of disc brake systems. Before assembling this Wilwood ProSpindle kit, double check the following to ensure a trouble free installation.
- Inspect the contents of this kit against the parts list to ensure that all components and hardware are included.
- Make sure this is the correct kit to fit the exact make and model year of your vehicle. This kit is designed for direct bolt-on installation to 1971-1987 Chevrolet C10 Trucks.
- **NOTE:** For 1971-1972 C10 applications - This spindle kit requires later model 1973-1987 C10 upper and lower ball joints, and tie rod ends, not included.
- Verify the new hub stud pattern (5 x 4.75 or 5 x 5.00) matches the lug pattern of the vehicles wheels.

Disassembly

- Disassemble the original equipment front brakes:
 - Raise the front wheels off the ground and support the front suspension according to the vehicle manufacturer's instructions.
 - Remove the front wheels and completely disassembly the stock brake system down to the bare spindles, then remove the spindles.

Assembly Instructions (numbers in parenthesis refer to the parts list and Figure 1 on the preceding pages):

- Apply red *Loctite*[®] 271 to the wheel stud (2) threads and install into the hub (3), Figure 1, and Photo 1. Torque to 77 ft-lb.
NOTE: There are two five lug patterns in the hub (5 x 4.75 and 5 x 5.00). Ensure the correct hub stud pattern is being used to fit the wheel application.



Photo 1



Photo 2

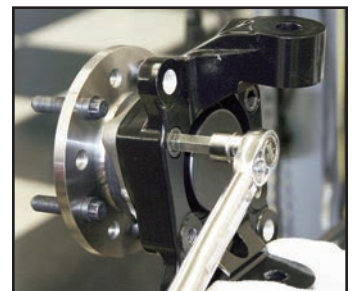

Photo 3

- Install the hub assembly into the spindle (1), Photo 2. Secure using bolts (4), Photo 3. Torque bolts to 100 ft-lbs.

Assembly Instructions

•Attach the steering arm (5) to the back side of the spindle (1) using bolts (6), Figure 1 and Photo 4. Torque bolts to 90 ft-lbs.

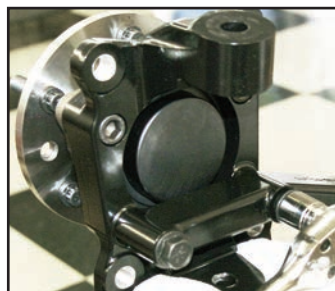

Photo 4

•Install the Wilwood ProSpindle assembly into place between the upper and lower ball joints, Photo 5. **NOTE:** For 1971-1972 C10 applications - This spindle kit requires later model 1973-1987 upper and lower ball joints, and tie rod ends, not included. Torque ball joints nuts to Original Equipment Manufacturer (OEM) specifications. Install new cotter pin, not supplied.



Photo 5

•Install the steering stop bolt (7), Figure 1 and Photo 6. Torque to 25 ft-lbs.



Photo 6

•Attach tie rod end to the new steering arm (5), Photo 7. Torque the tie rod end nut to OEM specifications. Install new cotter pin, not supplied.

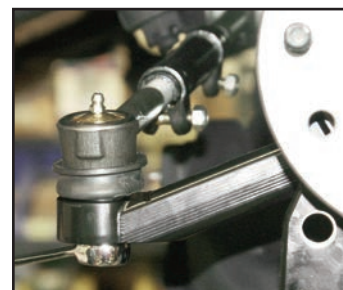

Photo 7

•Install the applicable Wilwood brake kit that was purchased separately per the instructions included with that kit.

•After brake kit installation, have a qualified technician perform a front end alignment on the vehicle.

Associated Components

| <u>PART NO.</u> | <u>DESCRIPTION</u> |
|-----------------|--|
| 260-8555 | Wilwood 1.00" Bore Aluminum Tandem Master Cylinder |
| 260-8556 | Wilwood 1.12" Bore Aluminum Tandem Master Cylinder |
| 260-13706 | Wilwood Residual Pressure Valve (2 lb for disc brakes) |
| 260-13707 | Wilwood Residual Pressure Valve (10 lb for drum brakes) |
| 260-8419 | Wilwood Proportioning Valve |
| 260-11179 | Wilwood Combination Proportioning Valve with Brake Light Switch |
| 290-0632 | Wilwood Racing Brake Fluid (Hi-Temp° 570) (12 oz) |
| 290-6209 | Wilwood Racing Brake Fluid (EXP 600 Plus) (16.9 oz) |
| 290-11084 | Wilwood "FIVE" DOT 5 Silicone Brake Fluid (12 oz) • NOT Recommended for Racing |
| 220-7056 | Stainless Steel Braided Flexline Kit, Universal, 14 Inch, Domestic, 3/8-24 IF |
| 220-7699 | Stainless Steel Braided Flexline Kit, Universal, 16 Inch, Domestic, 3/8-24 IF |
| 220-8307 | Stainless Steel Braided Flexline Kit, Universal, 18 Inch, Domestic, 3/8-24 IF |
| 220-8338 | Stainless Steel Braided Flexline Kit, Universal, 14 Inch, Metric 10mm x 1.0 |
| 220-6856 | Stainless Steel Braided Flexline Kit, Universal, 18 Inch, Metric 10mm x 1.0 |