



# INSTALLATION INSTRUCTIONS FOR WOLO LIGHTNING BRIGHT MODEL 3900

Your choice of a Wolo's warning light is the perfect choice to compliment your vehicle. Our warning lights are manufactured with the finest of material. Each light is tested before it is packaged. Our quality workmanship and components is Wolo's assurance of a product that will give years of dependable service.

## MOUNTING (Fig. A)

1. Select the location you wish to mount the warning light on. For best results you should make sure the lens is unobstructed so that the light can be seen 360 degrees.
2. Using the holes in the warning light's base, mark the two (2) hole locations for mounting the light. Lift the light from the mounting location and drill holes using a 3/16 inch bit.
3. If needed, drill a hole for the wires using a 5/16 inch bit and insert the plastic grommet into the hole. The plastic grommet will ensure that there are no sharp edges around hole that could damage the wires.
4. **IMPORTANT:** Use some silicone caulking around wires and plastic grommet if waterproofing is required.
5. Secure the base of the warning light to the vehicle using only the hardware provided by Wolo. To prevent vibration and water leaks use the rubber gasket provided.

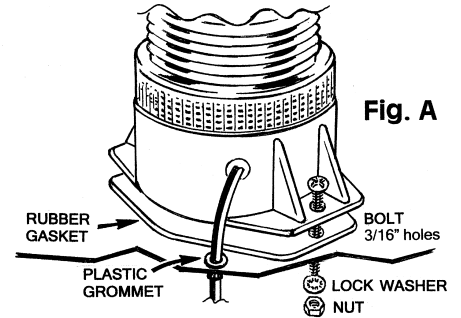

## WIRING (Fig. B)

6. Connect the warning light's **RED** wire to a power source (+) 12-24 volts such as battery, alternator, etc. use a 2-amp inline fuse (not provided).
7. Connect the warning light's **BLACK** wire to your on/off switch (not provided).
8. Connect the other terminal or wire from the on/off switch to ground, by placing the wire under any metal body bolt that is clean of paint and rust.
9. If you should need to lengthen any wires use 18 gauge or heavier. Make sure connections are taped and secured.

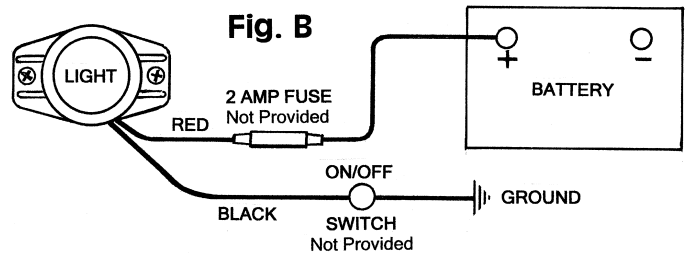

Rated to operate at: 12-24 volts DC.