



INFINITY-2® STROBE LIGHT BAR INSTALLATION MANUAL

Your purchase of a Wolo warning light is the perfect choice to compliment your vehicle. Wolo's warning lights are manufactured with the finest materials. Before it is packaged, each light is tested to meet our high standards to ensure a perfect working light. Our quality workmanship and components are Wolo's assurance that this product will provide years of dependable service.

Before installation of the light bar is attempted, it is important to read these instructions completely. The lives of people are dependent on a proper installation of the light bar to the vehicle. The person installing this light bar must have advanced knowledge of the proper method for mounting and securing the light bar to a vehicle's roof or exterior as well as knowledge of the vehicle's electrical system. Again, read this manual completely and note any messages marked "**IMPORTANT**" or "**WARNING**". A safe installation will prevent serious injury or damage to the vehicle.

The INFINITY-2 is completely wired and does not require any internal wiring by the installer. The power cable has all the required wires for a successful installation.

Installation of the INFINITY-2 Light Bar requires drilling to the vehicle. The installer must carefully inspect both sides of the selected locations to ensure that there are no components, wires and or any other vehicle part that could be damaged by drilling. **IMPORTANT:** Always de-burr any drilled holes, ensuring that there are no sharp edges. Install a rubber grommet into all metal holes that the wires are being routed through.

Always refer to the vehicle's shop manual for deployment location of air bags. Never install the light bar's switch control panel, wires and or components in the deployment area of any air bag. Improper installation could reduce the effectiveness of the vehicle's air bag system and or project an object that could cause serious personal injury or death to driver and passenger. The user/installer assumes all responsibility to properly access a safe mounting location of the light bar's control panel, so to provide ultimate safety to the driver and passengers inside the vehicle.

This light bar is a high current device. To operate this product at peak performance, the heavy gauge black wire should always be connected directly to the (-) negative battery post.

The vehicle operator and or maintenance department should inspect the light bar frequently to ensure all brackets are securely attached to the vehicle and that all mounting hardware is free of corrosion.

The light bar's control panel should be mounted in a location where the switches can be easily reached. Never attempt to turn light bar on/off when driving under hazardous conditions.

These installation instructions should always be kept and stored in a safe location so that they can be referred to when information, maintenance or reinstallation is required.

Failure to follow all safety precautions and installation procedures outlined in these instructions could result in property damage to the vehicle, serious injury or death to you or others.

MOUNTING LIGHT BAR

1. Place the light bar on the selected location of the vehicle's roof. A preferred mounting position on the roof is close to the B-pillar, which is the strongest part of the roof. **IMPORTANT:** Make sure the light bar is facing the correct direction.

2. Make sure the selected location of the light bar will allow the stainless steel straps to attach to the vehicle window ledge on both the driver's and passenger sides. See fig 1.

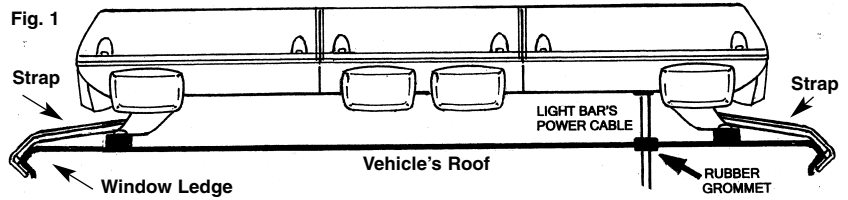

3. A 1/2" hole will need to be drilled in the roof to route the power cable into the interior of the vehicle. Mark the desired hole location; remove the light bar from the roof and drill the hole. The installer must lower the headliner to carefully inspect selected location to ensure that there are no components, wires and or any other vehicle part that could be damaged before drilling. **WARNING:** The roof has support members that span across from the driver's and passenger side of the vehicle. NEVER drill into a support member! It will be necessary to relocate cable's access hole so not to come in contact with support member.

4. **IMPORTANT:** Protect the vehicle's interior headliner from damage that could be caused when drilling the access hole for the light bar's power cable. Always allow a minimum distance of 6" to 8" between the roof and headliner by lowering the headliner before drilling the access hole.

5. **IMPORTANT:** Always de-burr the power cable access hole by using a round file so to ensure there are no sharp edges.

6. Supplied with the light bar is a rubber grommet; insert the grommet into the power cable access hole.

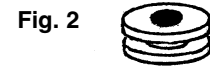

RUBBER GROMMET (SUPPLIED)

7. Position the light bar back onto the roof of the vehicle. There are two adjustable brackets located on the bottom of the light bar. The installer will need to adjust the location of the two brackets, each having two-(2) rubber pads, to be close to the edge of the roof. **IMPORTANT:** Always make sure that each of the protective rubber pads are in full contact with the roof. To adjust each bracket, loosen the four 14mm bolts, slide the bracket into position, and tighten the bolts securely. Repeat the same procedure for other bracket.

Fig. 3

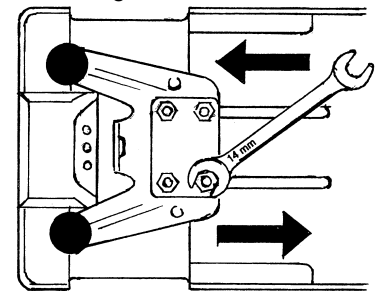

8. Remove the tension adjustment bolts from brackets located on the bottom of the light bar. See fig. 4.

9. Open the vehicle's door and determine the location that the stainless steel strap will clamp to the windows ledge. You will need to move the rubber weather-strip away from the vehicle. Only remove enough weather-strip so that the area where the stainless steel strap will be secured to the vehicle is exposed. Repeat the procedure for other side of vehicle.

10. Place one of the stainless steel strap's into position on the window ledge and insert the tension adjustment bolt through the strap's "L" bracket. Thread bolt into the light bar's bracket, hand tighten. **IMPORTANT:** The "L" bracket can be repositioned for proper installation by simply removing the screw securing it to the stainless steel strap. Reposition and secure the "L" bracket in preferred location using the screw and nut removed earlier. Repeat the procedure for other side of vehicle. **WARNING:** The two-(2) stainless steel straps included with the light bar are universal and should securely hold onto the window ledge of most vehicles. Some vehicles may require a custom designed strap for that vehicle's body. Always make sure that both straps have a full hold on the vehicles window ledge.

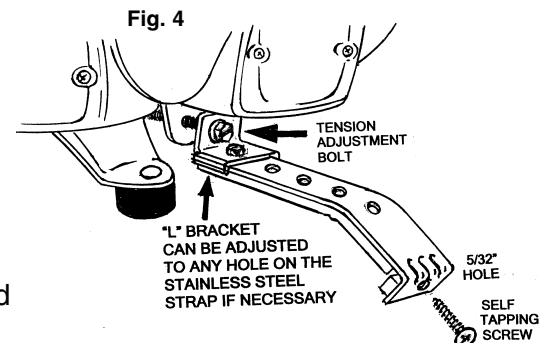

11. Tighten the two-(2) tension adjustment bolts evenly. While tightening the bolts make sure the light bar remains in the desired mounting position on the roof. Torque bolts to 10-12 ft-lbs. Failure to properly tighten the tension adjustment bolts and straps could result in damage to the vehicle and/or injury to driver or others.

12. The hook of the stainless steel strap that is secured to the vehicle's window ledge has a hole located in the middle. Use the hole as a template and drill a 5/32" hole and install the self-tapping screw provided. **IMPORTANT:** The installer may have to lower headliner and inspect the selected location to ensure that there are no components, wires and or any other vehicle part that could be damaged by drilling. See Fig. 4.

13. Place the weather-strip back into position.

14. Insert the power cable into the roof's access hole that was drilled earlier using the rubber grommet. Route the power cable into the B-pillar.

15. The power cable will make an approximate 90° bend into the B-pillar. Depending on the vehicle, this can sometimes be difficult, but it is the recommended procedure for proper installation. Installation will vary for each make and model vehicle and it is up to the installation technician's discretion whether to route the power cable as recommend through the B-pillar or use an alternative routing method. Route the power cable down to the bottom of the B-pillar and the pull the full length of the cable into the interior of the vehicle. See fig. 5.

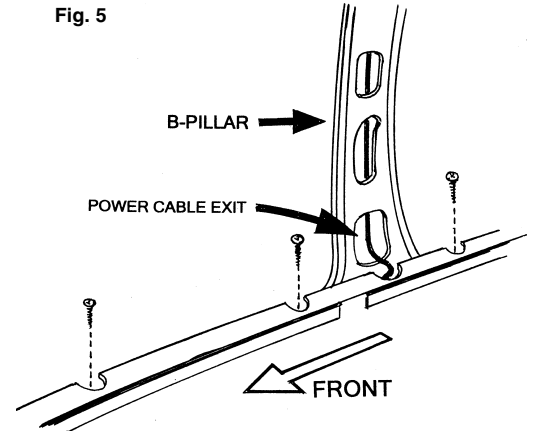

16. Make sure the power cable has been completely pulled into the vehicle, use silicon or similar waterproof material around the grommet and power cable to ensure a waterproof installation.

MOUNTING & WIRING SWITCH CONTROL PANEL

17. The light bar's switch control panel needs to be mounted in a location that can easily be reached. Make sure the mounting surface is clean and free of dust, dirt, oil, wax and etc. Using the double face tape provided, secure the control panel to the selected mounting location. See fig. 6.

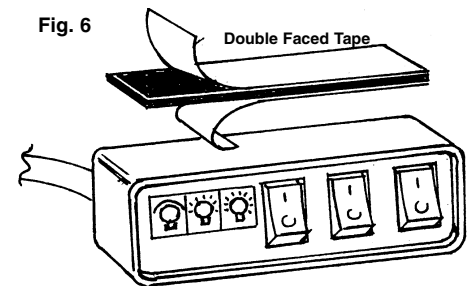

18. Route the light bar's power cable to the switch control panel that was mounted in the dash area in step #17.

19. The power cable has four-(4) different colored wires that need to be inserted into the plastic power plug. The plug is labeled showing the correct position for each color wire. **IMPORTANT:** Each of the four-(4) colored wires has a flat terminal with a protruding tab in the middle of the terminal. The tab locks the terminal into the plastic power plug. When inserting the terminal into the plug, the tab should be facing as shown in fig # 7.

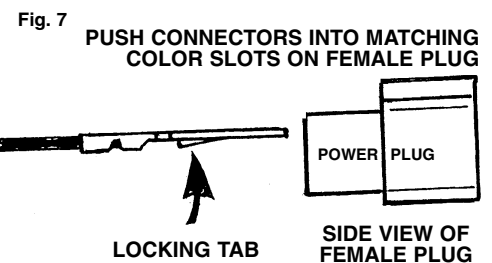

NOTE: The plug's middle position between the heavy gauge red and black wire is not used for this model light and should remain empty.

20. Connect the switch control panel's female plug to the power cable's male plug as shown in figure 8.

IMPORTANT: There are three inline fuses connected to the switch control panel wires:

Red wire: Controls upper strobe lights, replace with 3AG 12 amp fuse

Green wire: Controls alley and takedown lights, replace with 3AG 8 amp fuse

Yellow wire: Controls flashing marker lights, replace with 3AG 8 amp fuse

WIRING

21. **WARNING:** Failure to wire the light bar correctly could result in permanent damage to the light bar, the vehicle's electrical system and/or cause a fire. If any switch, fuse or wire is replaced, they must meet or exceed specifications rating specified in this manual. Any deviation to the electrical specifications is at the installers/users risk. **IMPORTANT:** Disconnect the vehicles battery before beginning any wiring. **IMPORTANT:** The heavy gauge RED wire must be connected to the 25 amp inline fuse (included with light bar) at the point of the battery connection. The fuse should never be more then ten-(10) inches from the battery post. See fig. 8.

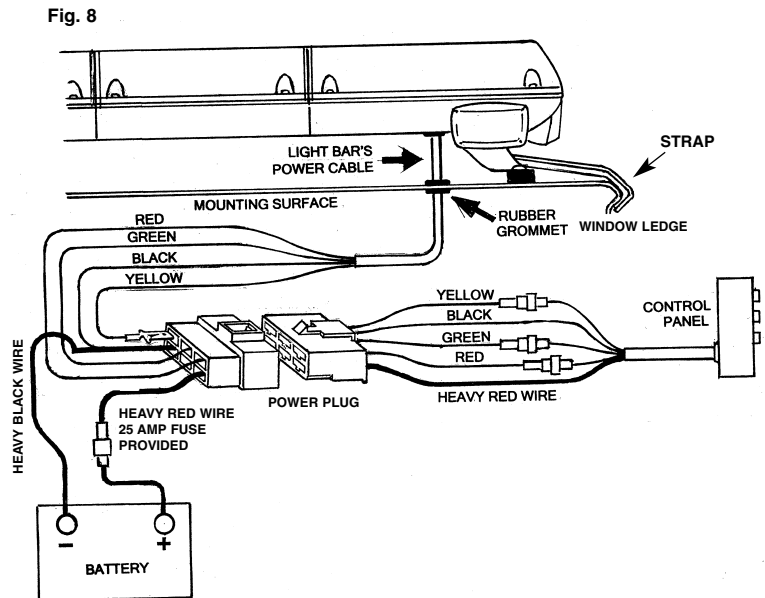

22. Route the heavy gauge RED & BLACK wires to the vehicles battery. If the power wires pass through any drilled holes or firewall, always use a rubber grommet to protect the vehicle.
23. Connect the light bar's BLACK wire to the (-) negative battery post. Make sure the connection is at a clean location free from corrosion or oxidation.
24. Secure the light bar's RED wire to the (+) positive battery post using the fuse holder provided with the 25-amp fuse. Make sure the connection is at a clean location free from corrosion or oxidation.
25. Make sure all wire connections are properly insulated so to prevent shorts.
26. Make sure all wires are securely fastened to vehicle using plastic wire ties or electrical tape (not provided). **WARNING:** Carefully inspect the interior driver's area to make sure the light bar wires or the vehicle's electrical system wires are not interfering with the operation of vehicle's controls; accelerator, brake, clutch pedals and etc.
26. Reconnect the vehicle's battery. Installation is complete.

BULB REPLACEMENT

WARNING: A serious injury can result if the bulb is touched when hot. Always allow five (5) minutes for the bulb to cool before removing. Always wear gloves and eye protection when removing the bulb because Halogen bulbs are pressurized and if broken, glass can be projected.

BULB REPLACEMENT FOR TOP CENTER TAKEDOWN LIGHT

27. You will need to remove the center lens from the light bar to change the bulb. Remove the four screws that secure the lens. Once the four screws are removed, the lens can be removed from the light's base.

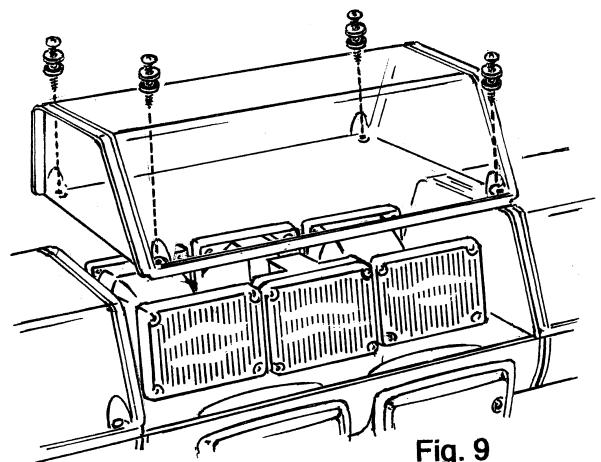
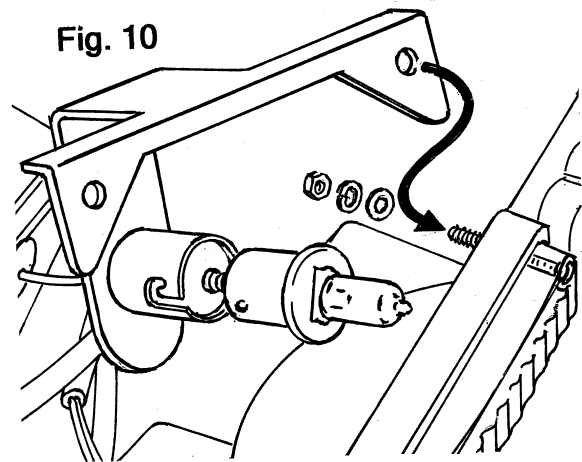

Fig. 9

28. Replacement bulb type: use only halogen 796/35watt halogen, 12 volt. Current draw: 2.73 amps.

29. The takedown halogen bulb is secured in place by the two screws at the top of the lens. Remove the two screws, washers and nuts. The bracket and light socket can now be removed from the back of the lens and you will have access to the halogen bulb. See fig. 10.



30. To remove bulb simply press inward and turn counter clockwise. The bulb should easily be able to be removed from the socket. Dispose of the bad bulb out of reach of children and in an environmentally safe manner. See fig. 10.

31. Never handle the glass of the new bulb with your fingers, doing such will shorten service life. If by accident you touch the bulb, clean with household glass cleaner.

32. Position the new bulb into the socket, depress the bulb and turn clockwise.

33. Insert the bulb back into the rear of the lens and secure with the two screws, washers and nuts removed earlier.

34. Place the lens back on the light bar's base and secure in place using the four screws removed earlier. **IMPORTANT:** There is a rubber gasket on the edge of the lens, make sure the gasket is positioned properly to prevent water and dirt from entering inside the light. Use care not to over tighten screws that secure lens.

BULB REPLACEMENT FOR MARKER AND ALLEY LIGHTS

35. You will need to remove the marker light lens to change the bulb. Remove the two Philips screws that secure the lens to the lights. Once the two screws are removed the lens can be removed from the light's base. See fig. 11.

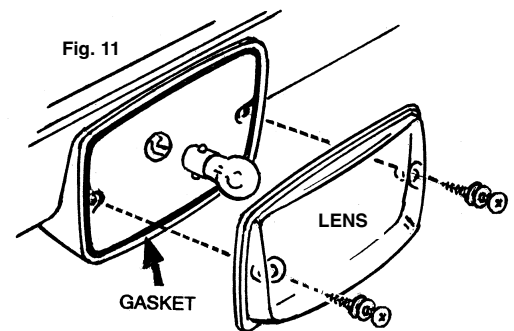

36. Replacement bulb type: use only 1156 or Sylvania P21W, 12 volt. Current draw: 2.1 amps.

37. To remove bulb simply press inward and turn counter clockwise. The bulb should easily be able to be removed from the socket. Dispose the bad bulb out of reach of children and in an environmentally safe manner.

38. Position the new bulb into the socket, depress the bulb and turn clockwise. **IMPORTANT:** There is a rubber gasket on the edge of the light base. Make sure the gasket is positioned properly to prevent water and dirt from entering inside the light. Use care not to over tighten screws that secure the lens.

39. Place the lens into position and secure with the two screws removed earlier. Be careful not to over tighten screws.

CLEANING

A scratched, dull or dirty lens, reflector or mirror can cause a reduction in brightness of warning light. Never use a caustic or petroleum base cleaner on any surface of the warning light. For best cleaning results, always use household glass cleaner or mild soap with a soft lint free rag. If the lens, reflector or mirror have scratches, or are dull, it is recommended those components be replaced so to ensure maximum brightness of the warning light.