



WATCHMAN™

Models 7824MP-A, 7826MP-B,
7827MP-R & 7828MP-BR

LED MINI BAR WARNING LIGHT

Your choice of a Wolo warning light is the perfect choice to complement your vehicle. Wolo's warning lights are manufactured with the finest materials. Each light is tested to meet our high standards before it is packaged, to assure a perfect working light. Our quality workmanship and components are Wolo's assurance of a product that will give years of dependable service.

MAGNET MOUNTING:

IMPORTANT: Vehicle roof construction varies for most vehicles as well as driving conditions. The vehicle should never be driven with this warning light magnetically mounted. It is possible that the light could dislodge off the mounting surface and cause damage, injury or death. Ignoring this warning shall be the sole responsibility of the user and or vehicle owner.

IMPORTANT: The magnets' holding power to the mounting surface is dependent upon the following: flatness, thickness, condition and finish of the mounting surface. For maximum magnet strength, follow these recommendations:

1. The vehicle's mounting surface should be kept clean and free of wax, dirt, dust and foreign particles.
2. The bottom of the magnets' rubber cover should be kept clean and free of wax, dirt, dust and foreign particles.
3. Always make sure that the mounting surface is flat and that all four (4) magnets are fully secured to the vehicle.
4. When necessary the mounting brackets' position can be adjusted by loosening the two (2) 8mm bolts that secure each bracket to the bottom of the light bar. Slide the bracket to the desired position and secure the bracket. Repeat procedure for the other bracket if necessary. See Fig. 1.
5. Once you have located the desired mounting location, you should make sure the lens is unobstructed so that the light can be seen 360 degrees.

IMPORTANT: Never attempt to secure the magnets to a vehicle that has a fabric or vinyl covering the mounting surface.

PERMANENT MOUNT

6. Remove the four magnets from the mounting brackets' by removing the rubber cover.
7. Using a 10mm wrench and a 10mm socket remove the nut securing the magnet, the magnet can be removed from the bracket. **IMPORTANT:** Do not discard the mounting hardware, it will be reused to permanently mount the light.
8. When necessary the mounting brackets position can be adjusted by loosening the two (2) 8mm bolts that secure each bracket to the bottom of the light bar. Slide the bracket to the desired position and secure the bracket. Repeat procedure for the other bracket if necessary. See Fig. 1.
9. Position the warning light on the desired mounting location. Using the light mounting brackets as a template, mark the four-mounting hole locations. (See Fig. 2) Remove the warning light from mounting surface.
10. Drill the four (4) marked locations to size 15/64".
11. Secure the light bar to the vehicle with the screws, rubber washers, flat washers and nuts that were removed in step 7. See Fig. 3.

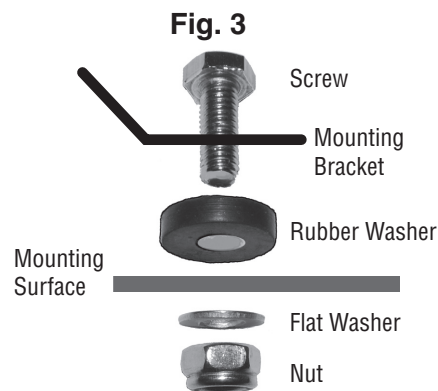
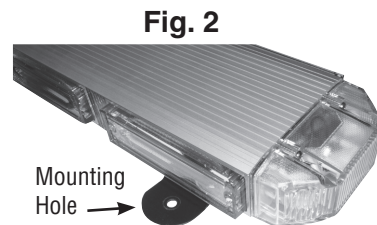
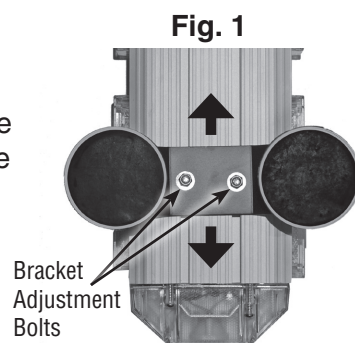

POWERING WARNING LIGHT: Fig. 4

12. To turn on the light bar, simply insert the light's cigarette lighter plug into the vehicle's power outlet. Press the on/off button on the back on the cigarette lighter plug. When the light is operating the LED on the plug's rocker switch will illuminate

13. To turn off the warning light, remove the cigarette lighter plug from the vehicle's power socket or position the on/off switch to off.

IMPORTANT: The warning light's cigarette lighter plug has a built-in fuse to protect the light and the vehicle.

If the warning light does not turn on when the plug is inserted into the vehicle power outlet, check the fuse by the following method: The tip of the power plug has a chrome push-in contact which is secured by the plastic nut. Unscrew the nut, and you will have access to the fuse. If the fuse needs to be replaced use a 5-amp fuse.

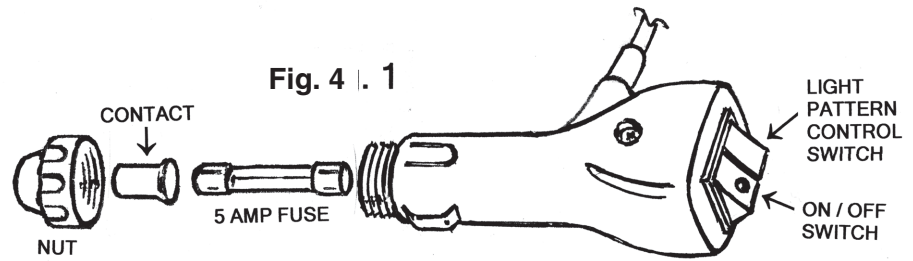

Follow the reverse procedure to re-assemble fuse back into power plug. See Fig. 4.

CHANGING LIGHT PATTERN:

There are twenty-four (24) different light patterns to choose from. Press the pattern selector switch button on the back of the cigarette lighter plug and the light pattern will change. Each time the pattern switch is pressed the light pattern will change.

CLEANING:

A scratched, dull or dirty lens can cause a reduction in brightness of warning light. Never use a caustic or petroleum base cleaner on any surface of the warning light. For best cleaning results, always use household glass cleaner or mild soap with a soft lint free rag.

SPECIFICATIONS

- Voltage: 10.8~13.8 Volts DC
- Peak Current: All LEDs on 2.37-amps
- LED Type Linear with magnifying lens, each LED module contains 6 x 1.5-watt LEDs
- 54 LEDs @ 1.5-watt 81 total wattage
- Light patterns: 24
- Clear lens throughout, color is produced by LEDs
- Mounting brackets can be repositioned to ensure a secure fit to the mounting surface
- L 24-5/8 in. x W 4-3/4 in. 2-7/8 in.