

LUXOR™

BY WOLO

LED LIGHT BAR INSTALLATION MANUAL

Your purchase of a Wolo warning light is the perfect choice to compliment your vehicle. Wolo's warning lights are manufactured with the finest materials. Before being packaged, each light is tested to meet our high standards and ensure a perfect working light. Our quality workmanship and components are Wolo's assurance that this product will provide years of dependable service.

Before installation of the light bar is attempted, it is important to read these instructions completely. The lives of people are dependent on a proper installation of the light bar to the vehicle. The person installing this light bar must have advanced knowledge of the proper method for mounting and securing the light bar to a vehicle's roof or exterior, as well as knowledge of the vehicle's electrical system. Again, read this manual completely and note any messages marked "**IMPORTANT**" or "**WARNING**". A safe installation will prevent serious injury or damage to the vehicle.

LUXOR comes completely wired and does not require any internal wiring by the installer. The power cable has all the required wires with factory installed terminals and connectors for a successful installation.

Installation of the LUXOR Light Bar requires drilling into the vehicle. The installer must carefully inspect both sides of the selected locations to ensure that there are no components, wires and/or any other vehicle part that could be damaged by drilling. **IMPORTANT:** Always de-burr any drilled holes, ensuring that there are no sharp edges. Install a rubber grommet into all metal holes that the wires are being routed through.

Always refer to the vehicle's shop manual for deployment location of air bags. Never install the light bar's switch control panel, wires and or components in the deployment area of any air bag. Improper installation could reduce the effectiveness of the vehicle's air bag system and or project an object that could cause serious personal injury or death to driver and passenger. The user/installer assumes all responsibility to properly access a safe mounting location of the light bar's control panel, to provide ultimate safety to the driver and passengers inside the vehicle.

The vehicle operator and or maintenance department should inspect the light bar frequently to ensure all brackets are securely attached to the vehicle and that all mounting hardware is free of corrosion.

The light bar's control panel should be mounted in a location where the switches can be easily reached. Never attempt to turn light bar on/off when driving under hazardous conditions.

These installation instructions should always be kept and stored in a safe location so that they can be referred to when information, maintenance or reinstallation is required.

Failure to follow all safety precautions and installation procedures outlined in these instructions could result in property damage to the vehicle, serious injury or death to you or others.

MOUNTING LIGHT BAR

1. Place the light bar on the selected location of the vehicle's roof. A preferred mounting position on the roof is close to the B-pillar, which is the strongest part of the roof. **IMPORTANT:** Make sure the light bar is facing the correct direction. **NOTE:** there is a label on the light's front lens indicating the take down lights.
2. Make sure the selected location of the light bar will allow the stainless steel straps to attach to the vehicle window ledge on both the driver's and passenger sides. See fig 1.

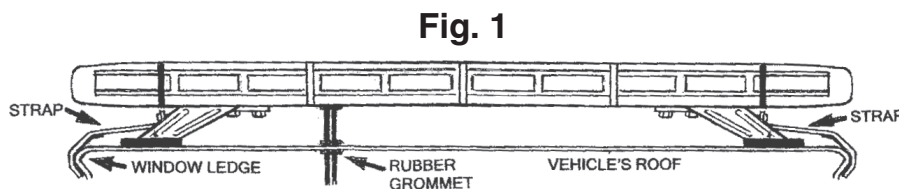

3. Drill an 11/16" hole into the roof, which will be the access point to route the cables into the interior of the vehicle (when at step number 13). Mark the desired hole location; remove the light bar from the roof and drill the hole. The installer must lower the headliner to carefully inspect selected location to ensure that there are no components, wires and or any other vehicle part that could be damaged before drilling. **WARNING:** The roof has support members that span across from the driver's and passenger side of the vehicle. NEVER drill into a support member! It will be necessary to relocate cable's access hole to not come into contact with support member.
4. **IMPORTANT:** Protect the vehicle's interior headliner from damage that could be caused when drilling the access hole for the light bar's power cable. Always allow a minimum distance of 6" to 8" between the roof and headliner by lowering the headliner before drilling the access hole.

Fig. 2

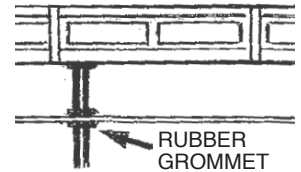

5. **IMPORTANT:** Always de-burr the access hole by using a round file to ensure there are no sharp edges. NOTE: The light bar's power cable has a rubber grommet in place that will be inserted the access hole after the cable is routed into the vehicle (when at step number 15). See fig 2.

6. Position the light bar back onto the roof of the vehicle. There are two adjustable brackets located on the bottom of the light bar. The installer will need to adjust the location of the two brackets, each having two- (2) rubber pads, to be close to the edge of the roof. **IMPORTANT:** Always make sure that each of the protective rubber pads are in full contact with the roof. To adjust each bracket, loosen the four 1/2" bolts, slide the bracket into position, and tighten the bolts securely. Repeat the same procedure for the bracket on the other end of the light bar. See fig 3.

Fig. 3

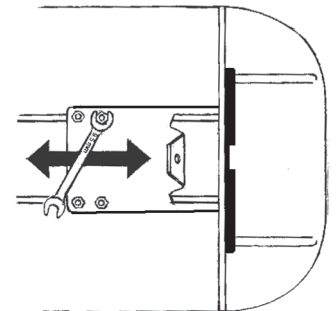

7. Remove the tension adjustment bolts from brackets located on the bottom of the light bar. See fig. 4.

8. Open the vehicle's door and determine the location that the stainless steel strap will clamp to the windows ledge. You may need to move the rubber weather-strip away from the vehicle. Only remove enough weather-strip so that the area where the stainless steel strap will be secured to the vehicle is exposed. Repeat the procedure for other side of vehicle.

9. Remove the blue protective film covering the stainless steel straps. Place one of the stainless steel straps into position on the window ledge so the installer can determine which holes in the stainless steel strap are best to attach the "L" bracket using the two carriage bolts, washers and nuts. Insert the tension adjustment bolt through the strap's "L" bracket and thread bolt into the light bar's bracket, hand tighten. **IMPORTANT:** The "L" bracket can be repositioned for proper installation by simply removing the screws securing it to the stainless steel strap. Reposition and secure the "L" bracket in preferred location using the screws, lock washers and nuts. Repeat the procedure for other side of vehicle.

Fig. 4

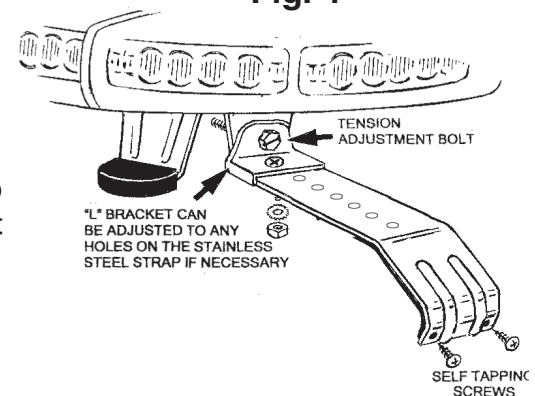

WARNING: The two- (2) stainless steel straps included with the light bar are universal and should securely hold onto the window ledge of most vehicles. Some vehicles may require a custom designed strap to properly secure the light bar to the vehicle's window ledge. Always make sure that both straps have a full hold on the vehicles window ledge.

10. Tighten the two- (2) tension adjustment bolts evenly. While tightening the bolts make sure the light bar remains in the desired mounting position on the roof. Torque bolts to 10-12 ft-lbs. Failure to properly tighten the tension adjustment bolts and straps could result in damage to the vehicle and/or injury to driver or others. See fig 4.

11. The hooked end of the stainless steel strap that is engaged to the vehicle's window ledge has two holes, which will secure the bracket to the vehicle with sheet metal screws. Use each of the holes in the bracket as a template mark and drill the required holes into the window ledge, drill to size 5/32". Secure the stainless steel strap to the window ledge with the self-tapping sheet metal screws. **IMPORTANT:** The installer may have to lower headliner and inspect the selected location to ensure that there are no components, wires and or any other vehicle part that could be damaged by drilling. See Fig. 4.
12. Place the weather-stripping back into position.
13. Insert the cables and the red and black wires into the access hole that was drilled into the roof earlier and make sure the rubber grommet has been installed into the drilled hole. Route the cables into the B-pillar.
14. The power cable will make an approximate 90° bend into the B-pillar. Depending on the vehicle, this can sometimes be difficult, but it is the recommended procedure for proper installation. Installation will vary for each make and model vehicle and it is up to the installation technician's discretion whether to route the power cable as recommend through the B-pillar or use an alternative routing method. Route cables down to the bottom of the B-pillar and the pull the full length of both cables into the interior of the vehicle. See fig. 5.
15. The rubber grommet that is attached to the power cable, is inserted into the access hole. See fig 2.
16. Make sure that the light's cable has been completely pulled into the vehicle, use silicon or similar waterproof material around the grommet and cables to ensure a waterproof installation.

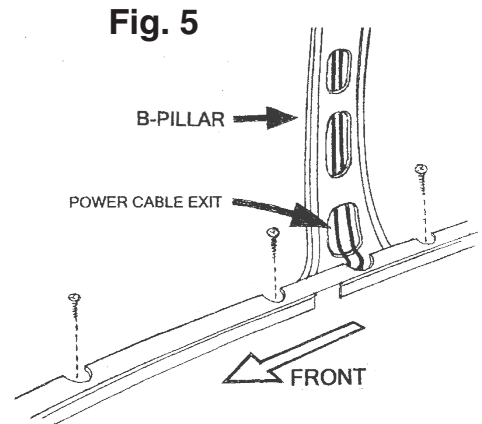

MOUNTING SWITCH CONTROL PANEL

The light bar's switch control panel needs to be mounted in a location that can easily be reached.

IMPORTANT: Do not connect the power plug to the switch controller until all mounting and wiring has been completed and a safety check has been completed. **WARNING:** If the vehicle is equipped with air bags, the installer **MUST** consult the vehicle's shop or build manual to ensure that light's switch controller and wires that will be connected to the switch controller, will not affect deployment of air bags. This switch controller must be installed only in a location recommended by vehicle manufacturer. If necessary, consult manufacturer for their recommendation. Failure to adhere to this warning could result in damage to the air bag and or reduce the effectiveness of the air bag, which could result in bodily injury, or death to you or others.

CAUTION

- Before drilling any surface for mounting siren of the switch controller or for routing wires carefully inspect the desired location to ensure that there are no components, wires and or any other vehicle part that could be damaged by drilling.
- The switch controller should not be mounted close to the vehicle's heater duct.

17. Remove the controller from the mounting bracket using the thumb screws on each side. Use the bracket as a template to mark the location of the mounting holes.
18. Drill four-(4) holes on the marked locations using a 5/32" drill bit.
19. Secure the swing-mounting bracket to the desired location using the sheet metal screws provided. See fig 6.
20. Reposition the switch controller back into the swing bracket, you can tilt and position the controller so that it is easily reachable by user. Tighten the two thumb screws that secure the switch controller to the swing bracket. See fig 6.

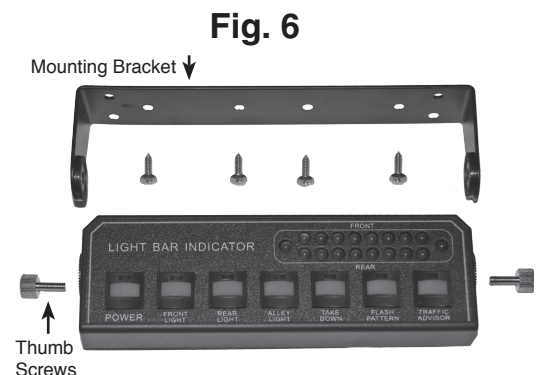

WIRING POWER CABLE See fig 7
Cable that has two wires (red and black)

21. **WARNING:** Failure to wire the light bar correctly could result in permanent damage to the light bar, the vehicle's electrical system and/or cause a fire. If any switch, fuse or wire is replaced, they must meet or exceed specifications rating specified in this manual. Any deviation to the electrical specifications is at the installers/users risk. **IMPORTANT:** Disconnect the vehicles battery before beginning any wiring. **IMPORTANT:** The RED wire must be connected to the 15-amp inline fuse (included with light bar) at the point of the 12-volt connection such as the fuse block, the vehicle's battery or any 12-volt power source which is rated by vehicle's manufacturer capable of handling 15-amperes. The fuse should never be more than ten (10) inches from the power source. If either the red or black wires need to be lengthened use 16 gauge or heavier wire. The light bar is a low current device, to operate this product at peak performance make sure all connections are clean of paint, rust and corrosion and firmly secured.

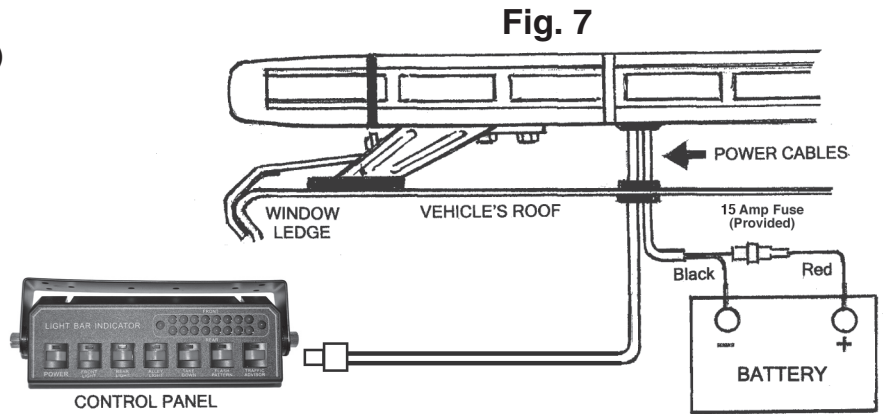

22. **RED & BLACK WIRES:** ROUTE the wires to the vehicles fuse block, accessory source or battery. If the power wires pass through any drilled holes or firewall, always use a rubber grommet to protect the wire cables.
23. **BLACK WIRE:** Connect to ground by securing wire under any metal body bolt or the negative (-) battery post. Make sure that the METAL surface around the bolt that secures the wire is clean of rust, oxidation and paint to make a good electrical connection. See fig 7.
24. **RED WIRE:** Connect to positive (+) 12-volts such as the fuse block, accessory power source in the dashboard area or the positive (+) battery post. Always use the fuse holder provided with the 15-amp fuse. Make sure the connection is at a location free from corrosion or oxidation. See fig 7.
25. To prevent shorts make sure all wire connections are properly insulated.
26. Make sure all wires are securely fastened to vehicle using plastic wire ties or electrical tape (not provided). **WARNING:** Carefully inspect the interior driver's area to make sure the light bar wires or the vehicle's electrical system wires are not interfering with the operation of vehicle's controls; accelerator, brake, clutch pedals and etc.
27. The cable white plug is connected to it's mate located on the back of the switch controller. The plug is designed only to connect in one position.
NOTE: The plugs locking tab is inserted facing downward. See fig 8.

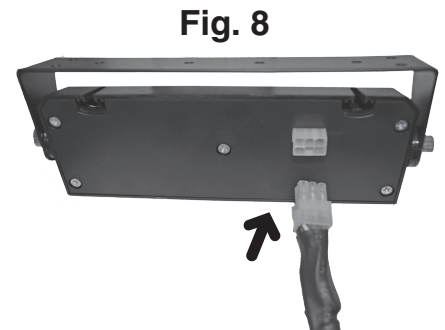

OPERATING LIGHT BAR

POWER SWITCH: Turns power on/off. There is a power indicator light above switch that will illuminate when power to the light bar is turned on.

FRONT LIGHT: Turns on/off the LED modules on the front of the light bar. Press and release front light switch and the light pattern will change: STEADY → ALTERNATING → SYNCHRONOUS → OFF

REAR LIGHT: Turns on/off the LED modules on the rear of the light bar. Press and release rear light switch and the light pattern will change: STEADY → ALTERNATING → SYNCHRONOUS → OFF

ALLEY LIGHT: Turns on/off the clear LED modules on the left & right sides of the light bar. Press and release the alley light switch and the light pattern will change: STEADY → ALTERNATING → SYNCHRONOUS → OFF

TAKE DOWN LIGHT: Turns on/off the clear LED modules in the front of the light bar. Press and release the alley light switch and the light pattern will change: STEADY → ALTERNATING → SYNCHRONOUS → OFF

FLASH PATTERN: Changes the flash pattern of the light bar.

TRAFFIC ADVISOR: Turns on/off LED modules in the rear of the light bar. Press and release the traffic advisor switch to select from three (3) different light patterns: Left to right → middle to sides → right to left → off. When the traffic advisory is turned off the rear facing modules will flash in sequence with the main flash pattern in use.

SPECIFICATIONS

Dimensions: L 47 in x W 12 in x H 2in (Height with mounting bracket 2.50 in)

Voltage: 10.8 ~ 13.8-VDC

Current: 7.5-amps @ 12-volts

LED: Total of 22 GEN 3.5 LED modules, each module contains four 3-watt LEDs

All models have clear lens throughout; color is produced by LEDs

Light Patterns: 15 selectable

Traffic Advisory: 3 selectable amber patterns, back of light

Takedown Lights: 3 selectable amber patterns

Alley Lights: 3 selectable amber patterns

Cable Length: 20 ft.

Mounting: Adjustable universal mounting system including stainless steel straps for window ledge mounting.

Switch Controller: Has LED flash pattern indicator, 7 push button switches and an adjustable mounting bracket.

CLEANING LENS

A scratched, dull or dirty lens can cause a reduction in brightness of warning light. Never use a caustic or petroleum based cleaner on any surface of the warning light. For best cleaning results, always use household glass cleaner or mild soap with a soft lint free rag. If the lens has scratches, or is dull, it is recommended those components be replaced to ensure maximum brightness of the warning light.