



LOOKOUT™ LED LIGHT BAR INSTALLATION MANUAL 7900 SERIES

Your purchase of a Wolo warning light is the perfect choice to compliment your vehicle. Wolo's warning lights are manufactured with the finest materials. Before being packaged, each light is tested to meet our high standards and ensure a perfect working light. Our quality workmanship and components are Wolo's assurance that this product will provide years of dependable service.

Before installation of the light bar is attempted, it is important to read these instructions completely. The lives of people are dependent on a proper installation of the light bar to the vehicle. The person installing this light bar must have advanced knowledge of the proper method for mounting and securing the light bar to a vehicle's roof or exterior, as well as knowledge of the vehicle's electrical system. Again, read this manual completely and note any messages marked "**IMPORTANT**" or "**WARNING**". A safe installation will prevent serious injury or damage to the vehicle.

LOOKOUT comes completely wired and does not require any internal wiring by the installer. The power cable has all the required wires with factory installed terminals and connectors for a successful installation.

Installation of the LOOKOUT Light Bar requires drilling into the vehicle. The installer must carefully inspect both sides of the selected locations to ensure that there are no components, wires and/or any other vehicle part that could be damaged by drilling. **IMPORTANT:** Always de-burr any drilled holes, ensuring that there are no sharp edges. Install a rubber grommet into all metal holes that the wires are being routed through.

Always refer to the vehicle's shop manual for deployment location of air bags. Never install the light bar's switch control panel, wires and or components in the deployment area of any air bag. Improper installation could reduce the effectiveness of the vehicle's air bag system and or project an object that could cause serious personal injury or death to driver and passenger. The user/installer assumes all responsibility to properly access a safe mounting location of the light bar's control panel, to provide ultimate safety to the driver and passengers inside the vehicle.

The vehicle operator and or maintenance department should inspect the light bar frequently to ensure all brackets are securely attached to the vehicle and that all mounting hardware is free of corrosion.

The light bar's control panel should be mounted in a location where the switches can be easily reached. Never attempt to turn light bar on/off when driving under hazardous conditions.

These installation instructions should always be kept and stored in a safe location so that they can be referred to when information, maintenance or reinstallation is required.

Failure to follow all safety precautions and installation procedures outlined in these instructions could result in property damage to the vehicle, serious injury or death to you or others.

MOUNTING LIGHT BAR

1. Place the light bar on the selected location of the vehicle's roof. A preferred mounting position on the roof is close to the B-pillar, which is the strongest part of the roof. **IMPORTANT:** Make sure the light bar is facing the correct direction. **NOTE:** there is a label on the light's front lens indicating the take down lights.

2. Make sure the selected location of the light bar will allow the stainless steel straps to attach to the vehicle window ledge on both the driver's and passenger sides. See fig 1.

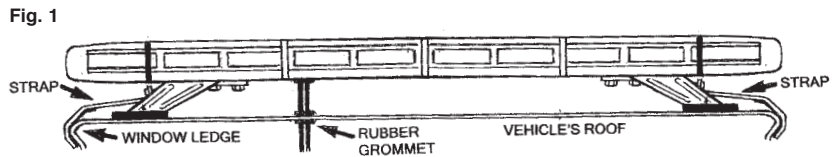

3. A 1/2" hole will need to be drilled in the roof to route both cables into the interior of the vehicle. Mark the desired hole location; remove the light bar from the roof and drill the hole. The installer must lower the headliner to carefully inspect selected location to ensure that there are no components, wires and or any other vehicle part that could be damaged before drilling. **WARNING:** The roof has support members that span across from the driver's and passenger side of the vehicle. NEVER drill into a support member! It will be necessary to relocate cable's access hole to not come into contact with support member.
4. **IMPORTANT:** Protect the vehicle's interior headliner from damage that could be caused when drilling the access hole for the light bar's power cable. Always allow a minimum distance of 6" to 8" between the roof and headliner by lowering the headliner before drilling the access hole.

5. **IMPORTANT:** Always de-burr the access hole by using a round file to ensure there are no sharp edges.
6. Supplied with the light bar is a rubber grommet; insert the grommet into the access hole.



RUBBER GROMMET (SUPPLIED)

7. Position the light bar back onto the roof of the vehicle. There are two adjustable brackets located on the bottom of the light bar. The installer will need to adjust the location of the two brackets, each having two-(2) rubber pads, to be close to the edge of the roof. **IMPORTANT:** Always make sure that each of the protective rubber pads are in full contact with the roof. To adjust each bracket, loosen the four 9.5mm bolts, slide the bracket into position, and tighten the bolts securely. Repeat the same procedure for the bracket on the other end of the light bar.

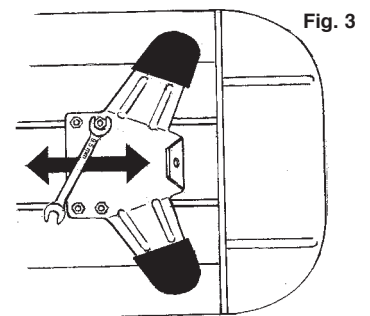

8. Remove the tension adjustment bolts from brackets located on the bottom of the light bar. See fig. 4.

9. Open the vehicle's door and determine the location that the stainless steel strap will clamp to the windows ledge. You may need to move the rubber weather-strip away from the vehicle. Only remove enough weather-strip so that the area where the stainless steel strap will be secured to the vehicle is exposed. Repeat the procedure for other side of vehicle.

10. Remove the blue protective film covering the stainless steel straps. Place one of the stainless steel straps into position on the window ledge so the installer can determine which holes in the stainless steel strap are best to attach the "L" bracket using the two carriage bolts, washers and nuts. Insert the tension adjustment bolt through the strap's "L" bracket and thread bolt into the light bar's bracket, hand tighten. **IMPORTANT:** The "L" bracket can be repositioned for proper installation by simply removing the screws securing it to the stainless steel strap. Reposition and secure the "L" bracket in preferred location using the screws, lock washers and nuts. Repeat the procedure for other side of vehicle. **WARNING:** The two-(2) stainless steel straps included with the light bar are universal and should securely hold onto the window ledge of most vehicles. Some vehicles may require a custom designed strap to properly secure the light bar to the vehicle's window ledge. Always make sure that both straps have a full hold on the vehicles window ledge.

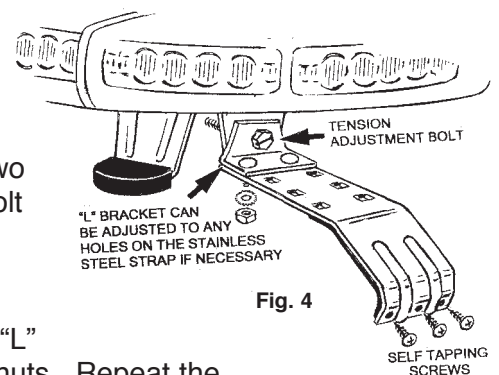

11. Tighten the two-(2) tension adjustment bolts evenly. While tightening the bolts make sure the light bar remains in the desired mounting position on the roof. Torque bolts to 10-12 ft-lbs. Failure to properly tighten the tension adjustment bolts and straps could result in damage to the vehicle and/or injury to driver or others.

12. The hooked end of the stainless steel strap that is engaged to the vehicle's window ledge has three holes, which will secure the bracket to the vehicle with sheet metal screws provided. Use each of the holes in the bracket as a template to drill a hole into the window ledge, drill to size 5/32". Secure the stainless steel strap to the window ledge with the self-tapping sheet metal screws provided. **IMPORTANT:** The installer may have to lower headliner and inspect the selected location to ensure that there are no components, wires and or any other vehicle part that could be damaged by drilling. See Fig. 4.

13. Place the weather-strip back into position.

14. Insert the two cables into the access hole that was drilled into the roof earlier and make sure the rubber grommet has been installed into the drilled hole. Route the cables into the B-pillar.

15. The power cable will make an approximate 90° bend into the B-pillar. Depending on the vehicle, this can sometimes be difficult, but it is the recommended procedure for proper installation. Installation will vary for each make and model vehicle and it is up to the installation technician's discretion whether to route the power cable as recommend through the B-pillar or use an alternative routing method. Route cables down to the bottom of the B-pillar and the pull the full length of both cables into the interior of the vehicle. See fig. 5.

16. Make sure that both cables have been completely pulled into the vehicle, use silicon or similar waterproof material around the grommet and cables to ensure a waterproof installation.

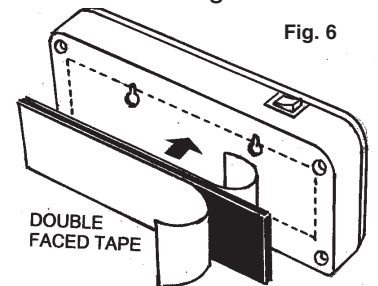
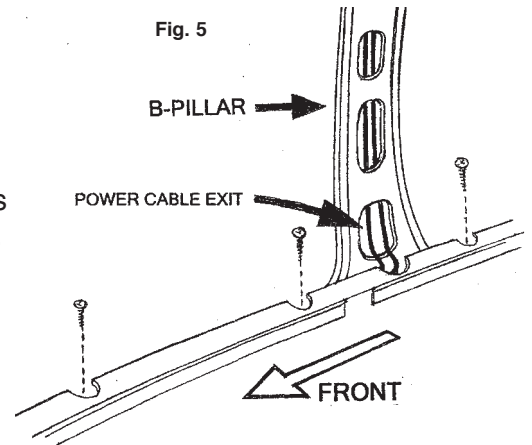

MOUNTING & WIRING SWITCH CONTROL PANEL

The light bar's switch control panel needs to be mounted in a location that can easily be reached. **Note:** there are two methods to mount the switch controller, either by using the double face tape provided or the plastic mounting bracket, which is secured to the mounting surface with screws. **IMPORTANT:** The installer must inspect the selected location to ensure that there are no components, wires and or any other vehicle part that could be damaged by drilling.

17A. **TAPE METHOD:** Remove the mounting bracket from the back of the switch controller by gently pushing downward on the bracket while pulling from the switch controller. Make sure the vehicle's mounting surface is clean and free of dust, dirt, oil, wax and etc. Using the double face tape provided, secure the control panel to the selected mounting location. See fig. 6 & 7.

17B. **SCREW METHOD:** Remove the mounting bracket from the back of the switch controller by gently pushing downward on the bracket while pulling from the switch controller. Using the mounting bracket as a template, mark the two screw hole locations and drill to size. 7/64". See fig. 7

18. You will need to drill a 7/64" hole on the right side of the switch controller in order to route the controller's wires through the mounting surface.

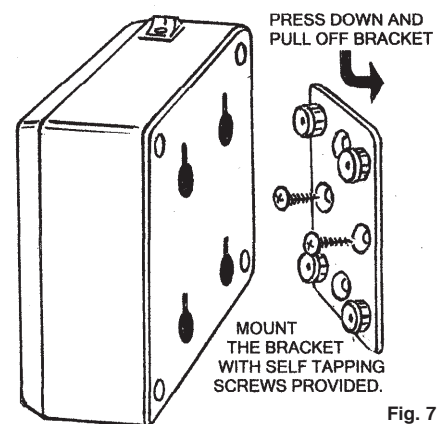

19. Route the cable that has six-(6) colored wires to the switch controller. Match the cable's colored wires to the same colored wires coming from the switch controller. Connect the wires together using the insulated bullet terminals' factory installed onto the wires ends. Make sure the terminals rubber insulator fully covers the metal terminal. See fig. 8.

WIRING POWER CABLE See fig 8
Cable that has two wires (red and black)

20. **WARNING:** Failure to wire the light bar correctly could result in permanent damage to the light bar, the vehicle's electrical system and/or cause a fire. If any switch, fuse or wire is replaced, they must meet or exceed specifications rating specified in this manual. Any deviation to the electrical specifications is at the installers/users risk. **IMPORTANT:** Disconnect the vehicles battery before beginning any wiring. **IMPORTANT:** The RED wire must be connected to the 10 amp inline fuse (included with light bar) at the point of the 12-volt connection such as the fuse block, the vehicle's battery or any 12-volt power source which is rated by vehicle's manufacturer capable of handling 10 amps. The fuse should never be more then ten (10) inches from the power source. If either the red or black wires need to be lengthened use 18 gauge or heavier wire. The light bar is a low current device, to operate this product at peak performance make sure all connections are clean of paint, rust and corrosion and firmly secured.
21. RED & BLACK WIRES: ROUTE the wires to the vehicles fuse block, accessory source or battery. If the power wires pass through any drilled holes or firewall, always use a rubber grommet to protect the wire cables. .

22. BLACK WIRE: Connect to ground by securing wire under any metal body bolt or the negative (-) battery post. Make sure that the METAL surface around the bolt that secures the wire is clean of rust, oxidation and paint to make a good electrical connection.
23. RED WIRE: Connect to positive (+) 12-volts such as the fuse block, accessory power source in the dashboard area or the positive (+) battery post. Always use the fuse holder provided with the 10-amp fuse. Make sure the connection is at a location free from corrosion or oxidation.

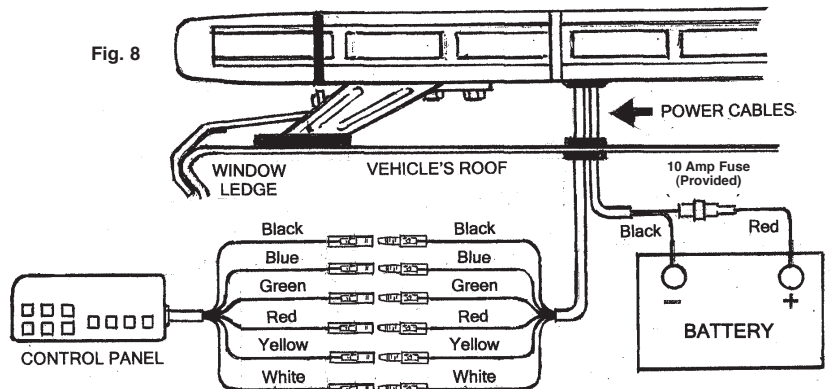

24. To prevent shorts make sure all wire connections are properly insulated.
25. Make sure all wires are securely fastened to vehicle using plastic wire ties or electrical tape (not provided). **WARNING:** Carefully inspect the interior driver's area to make sure the light bar wires or the vehicle's electrical system wires are not interfering with the operation of vehicle's controls; accelerator, brake, clutch pedals and etc.
26. Reconnect the vehicle's battery. Installation is complete.

OPERATING LIGHT BAR

27. The switch controller has an on/off switch located at the top left corner, position the switch to ON. There is a power indicator light that will illuminate on the front panel of the switch controller directly under the word POWER.

Traffic Advisory: There are three-(3) selectable traffic advisory light patterns to choose from. The

pattern in use will display on the switch controller's flash pattern indicator.

- To turn on traffic advisory: press the switch button **TRAFFIC FLASH**.
- Select the traffic advisory light pattern by using the **THREE ARROWS**.
- To turn off traffic advisory: press the switch button **TRAFFIC FLASH** until you hear a beep.

Warning light: There are Sixteen-(16) selectable warning light patterns to choose from. The pattern in use will display on the switch controller's flash pattern indicator.

- To turn on the warning light: press the switch button **FULL FLASH**.
- Select the warning light pattern by using the two **DIAMOND ARROWS**.
- To turn off the warning light: press the switch button **FULL FLASH** until you hear a beep.

Alley Lights: There are three-(3) selectable alley light patterns to choose from. The alley light in use will display on the switch controller's flash pattern indicator.

- To turn on the alley light **STEADY**: press and release the switch button LEFT ALLEY or RIGHT ALLEY one time fast.
- To turn on the alley light with a **DOUBLE FLASH**: press and release the switch button LEFT ALLEY or RIGHT ALLEY twice fast.
- To turn on the alley light with an **ON/OFF FLASH**: press and release the switch button LEFT ALLEY or RIGHT ALLEY three times fast.
- To turn off the alley light: press the switch button LEFT ALLEY or RIGHT ALLEY until you hear a beep.

Take Down Lights: There are three-(3) selectable take down light patterns to choose from. The take down light in use will display on the switch controller's flash pattern indicator.

- To turn on the take down light **STEADY**: press and release the switch button **TAKE DOWN** one time fast.
- To turn on the take down light with a **DOUBLE FLASH**: press and release the switch button **TAKE DOWN** twice fast.
- To turn on the take down light with an **ON/OFF FLASH**: press and release the switch button **TAKE DOWN** three times fast.
- To turn off the take down light: press the switch button **TAKE DOWN** until you hear a beep.

CLEANING

A scratched, dull or dirty lens can cause a reduction in brightness of warning light. Never use a caustic or petroleum based cleaner on any surface of the warning light. For best cleaning results, always use household glass cleaner or mild soap with a soft lint free rag. If the lens has scratches, or is dull, it is recommended those components be replaced to ensure maximum brightness of the warning light.