

INSTALLATION INSTRUCTIONS

For Model 856 Wolo Express™ 24-Volt Train Horn

Your purchase of a WOLO EXPRESS TRAIN HORN is the choice that will complement your vehicle. Wolo's products are manufactured with the finest materials. Each horn is tested to ensure it meets all manufacturing specifications, before it is packaged.

HORN INSTALLATION (Fig. A)

1. Locate a mounting location that is a solid metal surface such as the vehicle's frame or chassis to help prevent excessive vibration, which could damage the horn. For best results, the front of the horn should be unobstructed so that the sound can carry straight ahead.
IMPORTANT: When possible mount the trumpets with the open ends facing down. This will prevent water from entering into the trumpets and damaging the sound chamber.
2. Use the base of the horn as a template and mark the hole locations.
3. Drill to size 5/16" hole at each marked location.
4. Place the gasket between the mounting surface and the base of the horn.
5. Secure the horn with the hardware provided, tighten the bolts evenly.

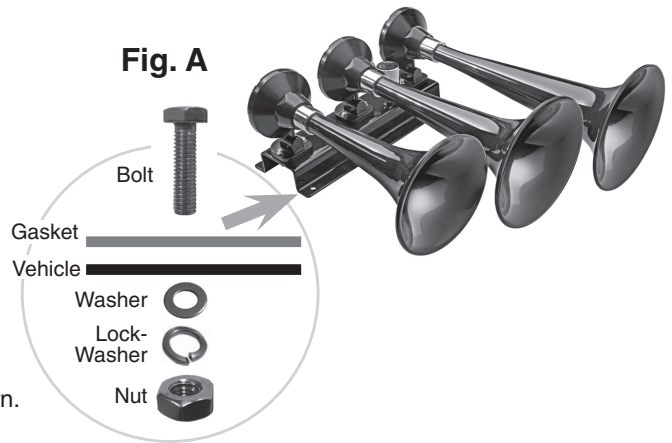

HOSE INSTALLATION (Fig. B)

6. Using the 1/4" plastic hose provided, cut to size to connect the air storage tank (not provided) to the horn's electric solenoid valve. Place the brass nut onto the hose. Push the hose onto the tank's male outlets fitting; tighten the brass nut onto outlet fitting. **CAUTION:** Do not over tighten brass nut.
7. Place the brass nut onto the end of the air hose. Push the air hose onto the male inlet fitting located on the electric solenoid valve.
8. Thread brass nut onto the inlet fitting and tighten. **CAUTION:** Do not over tighten brass nut.
9. Connect the other end of the hose to the vehicle's on-board air tank. Make sure that the onboard air system has no pressure before attempting to connect the hose to the tank.

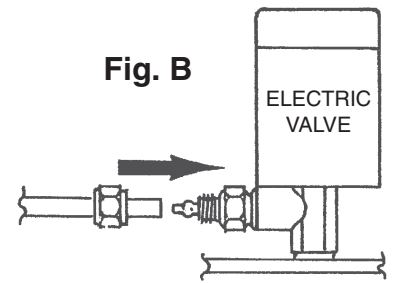

IMPORTANT: NEVER INSTALL THE HORN TO AN AIR TANK THAT CONTROLS THE VEHICLE'S AIR BRAKES OR ANY OTHER CRITICAL OPERATING SYSTEM.

ELECTRIC VALVE WIRING (Fig. C)

10. Connect one (1) wire from the electric valve to the positive +24-volts, such as: the vehicle's (+) battery post, alternator or fuse block.
IMPORTANT: Always protect this circuit with a three (3)-amp fuse (not included).
11. Connect the other wire of the electric solenoid valve to the horn switch.
12. Connect the horn switch's other terminal to ground, any metal body bolt that is clean of paint and rust.

