

INSTALLATION INSTRUCTIONS

For WESTERN EXPRESS Model 871

Your purchase of a Wolo Western Express Train Horn is the choice to compliment your vehicle. Wolo's products are manufactured with the finest materials. Each horn is tested to ensure it meets all manufacturing specifications.

Wolo are proud to offer a high quality product at the industries most competitive pricing!

Installation of the Western Express requires drilling into the vehicle. The installer must carefully inspect both sides of the selected locations to ensure that there are no components, wires and/or any other vehicle part that could be damaged by drilling.

IMPORTANT: Always de-burr any drilled holes, ensuring that there are no sharp edges. Install a rubber grommet into all metal holes that the wires are being routed through.

Always refer to the vehicle's shop manual for deployment location of air bags. Never install the horn switch, wires and or components in the deployment area of any air bag. Improper installation could reduce the effectiveness of the vehicle's air bag system and or project an object that could cause serious personal injury or death to driver and passenger. The user/installer assumes all responsibility to properly access a safe mounting location, to provide ultimate safety to the driver and passengers inside the vehicle.

MOUNTING TRUMPETS: FIG. 1

1. Position each trumpet with the open end facing downward when possible, this will prevent water and dirt from entering into the trumpet's sound chamber. **CAUTION:** Always keep the trumpets at a distance not less than 6" from exhaust manifolds, any component parts that get hot and any moving parts.
 2. Use the trumpet's mounting base as a template, mark the two mounting hole locations and drill to size: 5/16".
 3. Place the rubber gasket provided, between the mounting surface and the horn's mounting base.
 4. Secure the trumpet to the mounting location using the hardware provided.
 5. Repeat the same mounting procedure for the other trumpet.
- NOTE:** The Western Express is a high-pressure horn, for ease of installation, the trumpets do not have to be mounted in the same location.

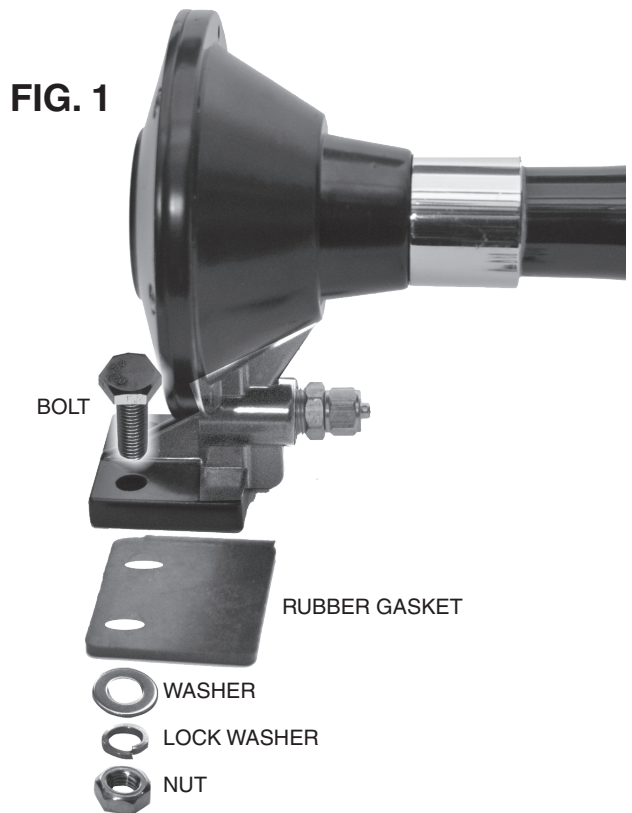

MOUNTING ELECTRIC SOLENOID: Fig. 2 and 2A

6. The mounting location for electric solenoid valve needs to be in a dry location and safe from engine and exhaust manifold heat.
7. Remove the brass outlet air fitting from the solenoid by turning the fitting counter-clockwise. (**NOTE:** Only the outlet fitting can be separated from the valve).
8. Use the solenoid's mounting bracket as a template and mark the location of the mounting holes. Drill to size: 1/4".
9. Secure the mounting bracket using the hardware provided. The solenoid can be rotated on the bracket to best fit your space (Fig. 2A).
10. Secure the solenoid to the mounting bracket by threading the brass outlet fitting (removed in step number 7) back into the solenoid and tighten using a wrench.

IMPORTANT: The black plastic housing that has the two 1/4" male electrical terminals, can be repositioned by loosening the nut located on the top of the solenoid. Reposition if required and tighten the nut (Fig. 2A).

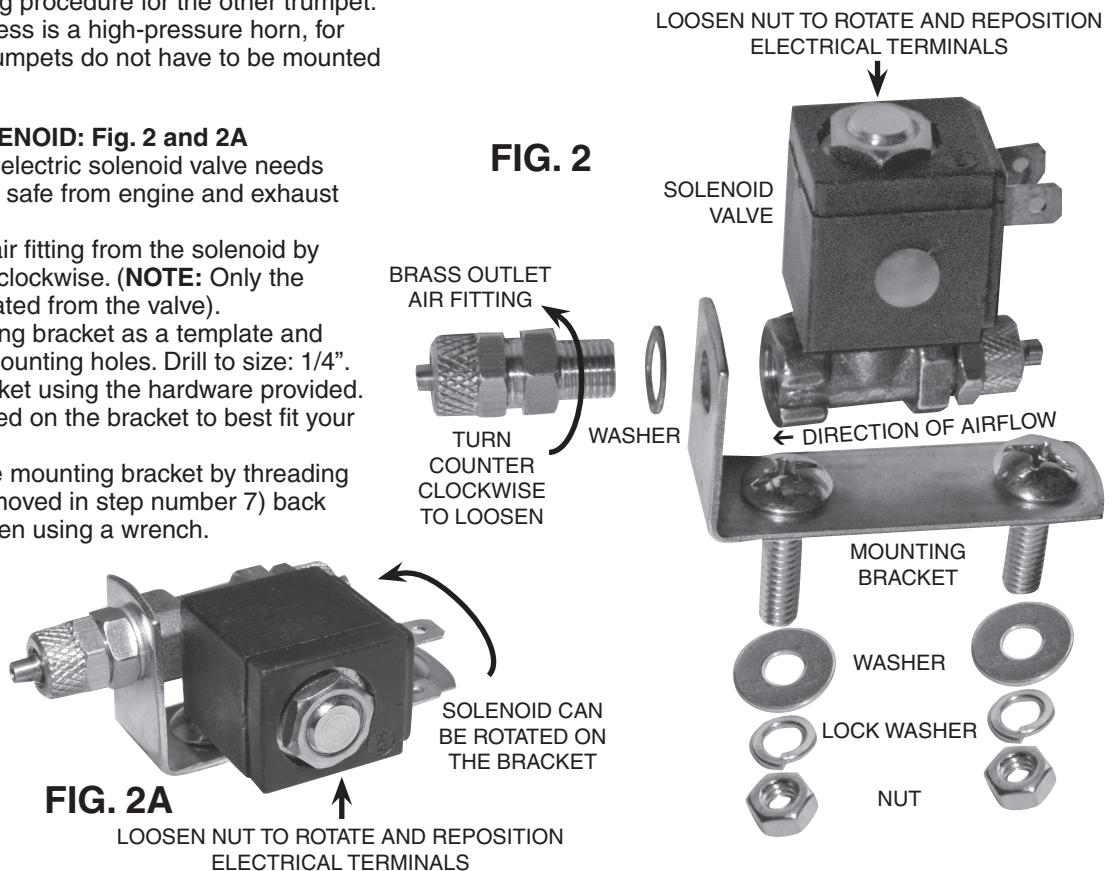

HIGH PRESSURE HOSE CONNECTIONS: Fig. 3

11. Cut the 1/4" high-pressure hose provided, to length so to connect the trumpet to the "Y" air splitter.
12. Secure the 1/4" high-pressure hose to the trumpet by removing the brass nut from the air fitting. Slide the nut onto the 1/4" high-pressure hose.
13. Push the 1/4" high-pressure hose onto the trumpet's brass fitting.
14. Tighten the brass nut to the air fitting. **CAUTION:** Do not over tighten brass nut.
15. The other end of the high-pressure hose is pushed into one of the ports of the "Y" air splitter. The hose can be removed anytime from the air splitter by pushing inward on the black ring that the hose was pushed into. **NOTE:** To ensure a leak free installation, make sure the end of the hose is cut evenly.
16. Repeat the same procedure to connect the 1/4" hose to the other trumpet.
17. Cut the 1/4" high-pressure hose provided to length so to connect the solenoid's air outlet to the "Y" air splitter.
18. The "Y" air splitter can be secured to the vehicle; mark hole locations and drill to size: 3/32". Secure air splitter using the sheet metal screw provided.

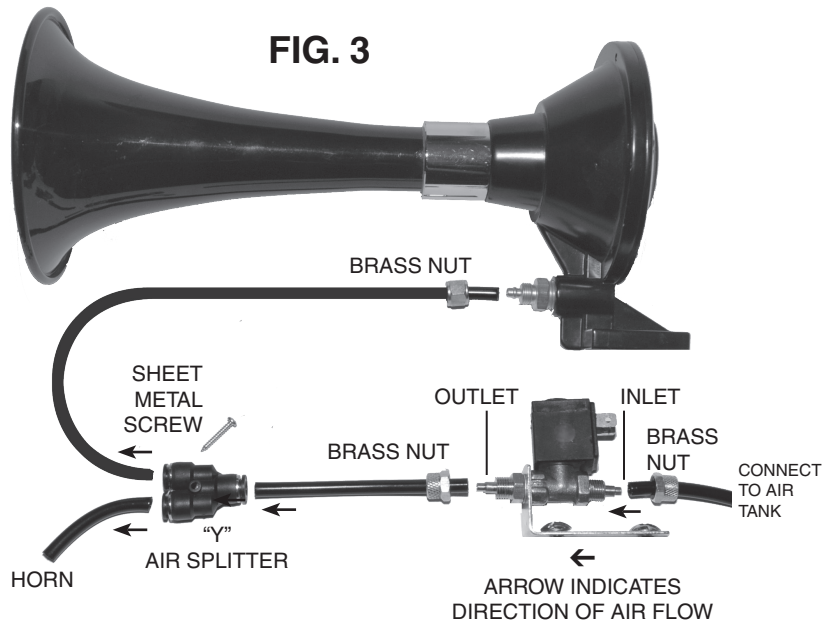

IMPORTANT: There is an arrow ← on the solenoid, which shows the direction of the airflow entering and exiting the valve.

19. Cut the 1/4" high-pressure hose provided to length so to connect the solenoid's inlet to the air storage tank.

IMPORTANT: Make sure that the onboard air system has no pressure before attempting to connect hose to tank.

IMPORTANT: NEVER INSTALL THE HORN TO AN AIR TANK THAT CONTROLS THE AIR BRAKES OR ANY OTHER CRITICAL OPERATING SYSTEM.

WIRING SOLENOID: Fig. 4

WARNING: Failure to wire the solenoid correctly could result in permanent damage to the vehicle's electrical system and/or cause a fire. If any fuse or wire needs to be replaced or extended, they must meet or exceed specifications rating specified in this manual. Any deviation to the electrical specifications is at the installers/users risk. **IMPORTANT:** Disconnect the vehicles battery before beginning any wiring. **IMPORTANT:** The solenoid wire must be connected to the 3-amp inline fuse (included with horn) at the point of the +24-volt connection such as the fuse block, the vehicle's battery or any 24-volt power source which is rated by vehicle's manufacturer capable of handling 3-amperes. If either of the solenoid wires need to be lengthened use 18 gauge or heavier wire. The solenoid is a low current device, to operate this product at peak performance make sure all connections are clean of paint, rust and corrosion and firmly secured.

20. Connect one (1) of the solenoid's male 1/4" wire terminals to a positive (+) power source such as the vehicle's (+) battery terminal, alternator, fuse block or etc. **IMPORTANT:** Always use the in-line fuse provided to protect the vehicle. The fuse should not be more than 10" from the power source. (Note: if you need to replace the fuse use the same type, 3-amp.)

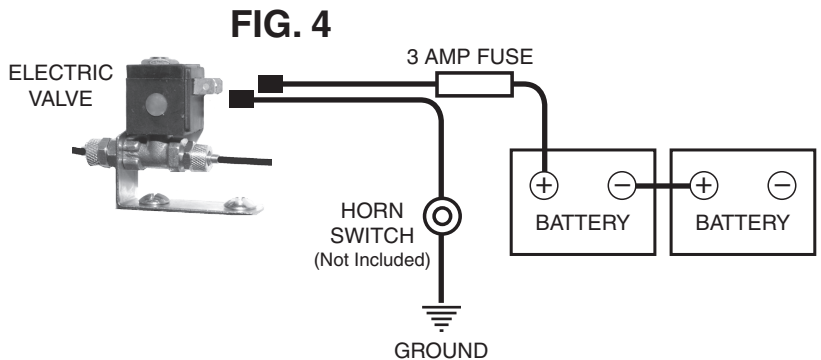

21. Connect the solenoid's other 1/4" male terminal to the horn switch. (Horn switch not included).
22. Connect the horn switch's other terminal to ground, any metal body bolt that is clean of paint and rust.
23. Reconnect the vehicle's battery cable, fill air tank, and test horn.

NOTE: Tape all connections and secure all wires. Check for any air leaks using soapy water.