



Installation Instructions for Model 800 TIGER[®] AIR TANK & COMPRESSOR and Model 840 TURBO[®] AIR TANK & COMPRESSOR

Your purchase of a Wolo Air Tank & Compressor is a perfect choice to power your high-pressure air horns. The Wolo name, with more than fifty years experience, is your guarantee of a superior horn product.

COMPRESSOR INSTALLATION (Fig. 1):

1. Locate an area in the engine compartment that is dry and safe from the heat of the exhaust manifold. Try to mount compressor as far to the front of vehicle as possible to provide optimum airflow around compressor.

IMPORTANT! Do not mount on a plastic fender well or on flexible material.

2. Using the compressors mounting base as a template, mark the hole locations and drill to size, use a 3/16" drill bit. Secure the compressor to the mounting surface using the hardware provided.

Fig. 1

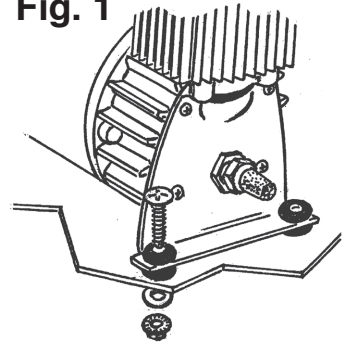

TANK INSTALLATION (Fig. 2):

3. Locate a convenient area in the vehicle to mount the air storage tank.

IMPORTANT! When selecting a mounting location for the tank, make sure that the compressor's metal braided hose is close enough to connect to the tanks brass female fitting.

4. Use the tanks mounting bracket as a template, mark the hole locations and drill to size, using a 15/64" drill bit. Secure tank with hardware provided.

Fig. 2

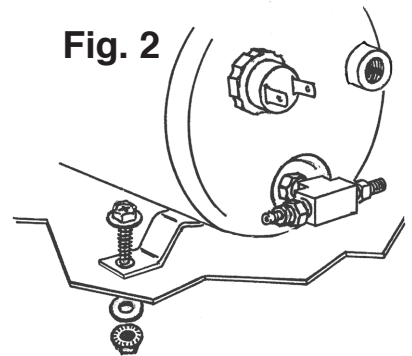

HOSE INSTALLATION (Fig. 3 and Fig 4):

5. Connect the metal braided hose from the compressor to tanks female brass inlet fitting. (Fig 3.) **IMPORTANT!** The threaded end of the braided hose has been wrapped with teflon[®] tape to help prevent an air leak, do not remove the tape.

6. Using the plastic hose provided, cut to size and connect the tank to the horn's lanyard or solenoid valve. Place the brass-fitting nut onto the plastic hose, push the hose onto the tanks outlet fitting, and tighten the brass nut onto the outlet fitting. (Fig 4.)

CAUTION: Do not over tighten the brass nut.

7. Connect the other end of plastic hose to the horn's lanyard or solenoid valve.

Fig. 3

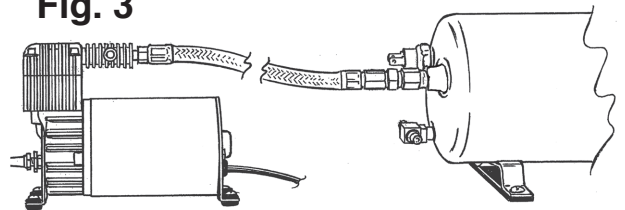
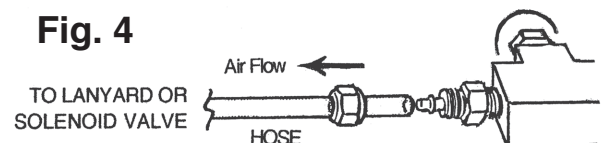

Fig. 4



WIRING COMPRESSOR (Fig. 5):

8. The compressor's red wire is connected to a (+) 12-volt power source, using the fuse provided.

IMPORTANT! The fuse must be connected directly to the power source.

IMPORTANT! The red wire must be connected to a (+) 12-volt power source only when the vehicle ignition is turned on. This will protect your compressor from running continuously and being damaged, if an air leak develops when the vehicle is not in operation. Suggested connection points are: blower motor, windshield wiper motor, or the accessory terminal on the fuse panel. Make sure the connection point has a wire that is as heavy as the compressor wire and the connection point is capable of handling 20 amps. Remove fuse from fuse holder until installation is complete.

OPTIONAL: A switch can be installed into the compressor's red wire. This will permit the driver to turn-off the system if it is not required. (Fig 5.)

9. The rubber boot with the two black wires will connect to the pressure switch.

IMPORTANT: It is recommended that both black wires be pushed forward into the plug so that 1/4" female terminals are exposed.

10. The 1/4" female terminal connected to one of the black wires, is connected to a male terminal of the pressure switch. Repeat the procedure for the other for the other black wire.

NOTE: There is no polarity, so either black wire can be connected to either pressure switch terminal.

11. Push the rubber boot onto the pressure switch.

12. The black wire with the loop terminal is connected to ground; secure the wire's terminal to either the (-) side of vehicles battery or under any metal body bolt. Make sure that ground connection is free of rust and paint.

NOTE: The compressor is now ready to be used, install the fuse back into the fuse holder and the compressor will automatically start. When the pressure drops below 80 PSI in the tank, the pressure switch will automatically turn on the compressor. When the tank pressure is approximately 120 PSI the compressor will automatically turn off. If the compressor does not shut off after 4 minutes of running time; check all air hose connections for leaks. Use soapy water or bubble solution on each fitting, while the compressor is pumping. Use a thread sealant if leak persists after tightening.

CAUTION: Do not touch compressor or fittings with bare hands during or immediately after usage, they will be hot.

IMPORTANT! Compressor is equipped with an internal THERMAL OVERLOAD PROTECTOR. If compressor should shut off before the tank has been filled to the pressure switch's turn off pressure, do not attempt to restart compressor. Allow compressor to cool off for approximately 40 minutes before resuming use.

