

INSTALLATION INSTRUCTIONS

FOR MODEL 853 PHILLY EXPRESS TRAIN HORN



HORN INSTALLATION (Fig. A)

1. Locate a mounting location that is a solid metal surface such as the vehicle's frame or chassis to help prevent excessive vibration, which could damage the horn. **IMPORTANT:** Do not mount horn on a plastic fender well or flexible material. For best results, the front of the horn should be unobstructed so that the sound can carry straight ahead.
2. Use the base of the horn as a template, mark the hole locations and drill to size.
3. Place the gasket between the mounting surface and the base of the horn.
4. Secure the horn with the hardware provided and tighten evenly.

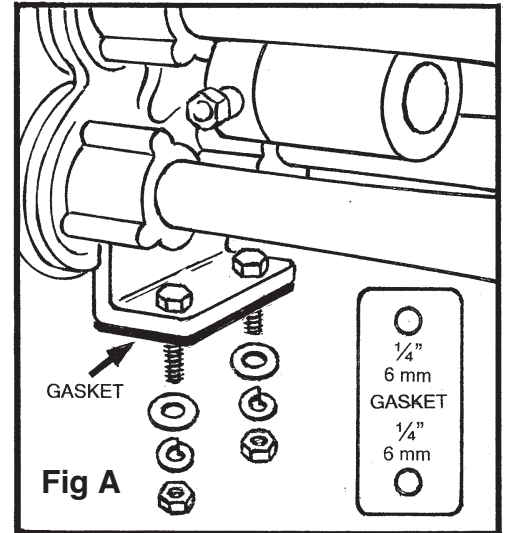

HOSE INSTALLATION (Fig. B)

5. Use 1/4" O.D. plastic hose (not provided), cut to size in order to connect the horn's electric solenoid valve to the tank of the vehicle's high pressure on-board air system.
6. Place the brass nut onto the end of the air hose. Push the hose onto the male inlet fitting located on the electric solenoid valve.
7. Thread brass nut onto the male fitting and tighten. **CAUTION:** Do not over tighten brass nut.
8. Connect the other end of the hose to the vehicle's on-board air tank. Make sure that the on-board air system has no pressure before attempting to connect hose to tank. **IMPORTANT:** NEVER INSTALL THE HORN TO AN AIR TANK THAT CONTROLS THE AIR BRAKES OR ANY OTHER CRITICAL OPERATING SYSTEM.

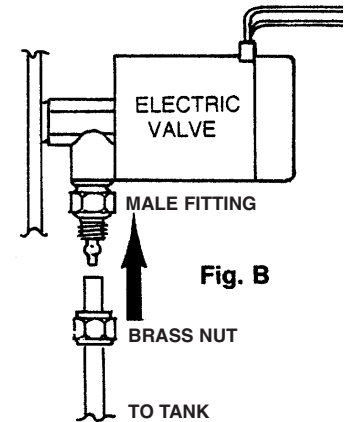

ELECTRIC VALVE WIRING (Fig. C)

9. Connect one (1) wire from the electric valve to the positive (+) battery terminal, alternator, etc. Always protect this circuit with a three (3) amp fuse (not included).
10. Connect the other wire of the electric solenoid valve to the horn switch (not included).
11. Connect the horn switch's other terminal to ground, any metal body bolt that is clean of paint and rust.

