



## **D2201 Installation Instructions** **2012-2017 Dodge Ram 1500 4WD** **2" Adventure Series Suspension System**

### **Read and understand all instructions and warnings prior to installation of product and operation of vehicle.**

Zone Offroad Products recommends this system be installed by a professional technician. In addition to these instructions, professional knowledge of disassembly/ reassembly procedures and post installation checks must be known. Minimum tool requirements include the following: Assorted metric and standard wrenches, hammer, hydraulic floor jack and a set of jack stands. See the "Special Tools Required" section for additional tools needed to complete this installation properly and safely.

#### **» PRODUCT SAFETY WARNING**

Certain Zone Suspension Products are intended to improve off-road performance. Modifying your vehicle for off-road use may result in the vehicle handling differently than a factory equipped vehicle. Extreme care must be used to prevent loss of control or vehicle rollover. Failure to drive your modified vehicle safely may result in serious injury or death. Zone Offroad Products does not recommend the combined use of suspension lifts, body lifts, or other lifting devices.

You should never operate your modified vehicle under the influence of alcohol or drugs. Always drive your modified vehicle at reduced speeds to ensure your ability to control your vehicle under all driving conditions. Always wear your seat belt.

#### **Difficulty Level**

easy 1 (2) 3 4 5 difficult

Estimated installation: 3-4 hours

#### **Special Tools Required**

Ball Joint Separation Tool

#### **Tire/Wheel Fitment**

33x12.50 with 4.75" Backspacing

#### **» PRE-INSTALLATION NOTES**

1. Special literature required: OE Service Manual for model/year of vehicle. Refer to manual for proper disassembly/reassembly procedures of OE and related components.
2. Adhere to recommendations when replacement fasteners, retainers and keepers are called out in the OE manual.
3. Larger rim and tire combinations may increase leverage on suspension, steering, and related components. When selecting combinations larger than OE, consider the additional stress you could be inducing on the OE and related components.
4. Post suspension system vehicles may experience drive line vibrations. Angles may require tuning, slider on shaft may require replacement, shafts may need to be lengthened or trued, and U-joints may need to be replaced.
5. Secure and properly block vehicle prior to installation of Zone Offroad Products. Always wear safety glasses when using power tools.
6. If installation is to be performed without a hoist, Zone Offroad Products recommends rear alterations first.
7. Due to payload options and initial ride height variances, the amount of lift is a base figure. Final ride height dimensions may vary in accordance to original vehicle attitude. Always measure the attitude prior to beginning installation.

**\*Important\* Verify you have all of the kit components before beginning installation.**

## D2300 Kit Contents

Qty	Part
1	Drv Upper Control Arm
1	Pass Upper Control Arm
2	Straight grease fitting
2	Ball joint aluminum slugs
2	2-5/16" Circlip - yellow zinc
2	2-1/4"OD x 3/32 O-ring
4	Upper control arm factory style bushings
2	Upper Control arm ball joints

## Strut Spacer

Qty	Part
2	2 strut spacer
1	Strut spacer bolt pack
1	Loctite
2	Sway bar link spacer
2	Bushing Preload Plate

### Kit Fitment notes:

1. Do not use this kit with Bilstein leveling struts, or with any other form of suspension lift.
2. Do not install spacer kit without upper control arms, the factory upper ball joint will be extended past operating range. Vehicle damage may occur.

## INSTALLATION INSTRUCTIONS

### » DISASSEMBLY

1. The factory service manual specifically states that striking the knuckle to loosen the ball joints or tie rod ends is prohibited. Striking the aluminum knuckle can damage it. A special puller tool #8677 (or equivalent ball joint tool) is recommended to be used to separate these components from the knuckle.
2. Park vehicle on clean flat and level surface. Block rear wheels for safety.
3. Raise front of vehicle and support frame rails with jack stands. Remove the front wheels
4. Remove sway bar nut from the sway bar links at the sway bar, remove bushings and cup washers. Fig 1

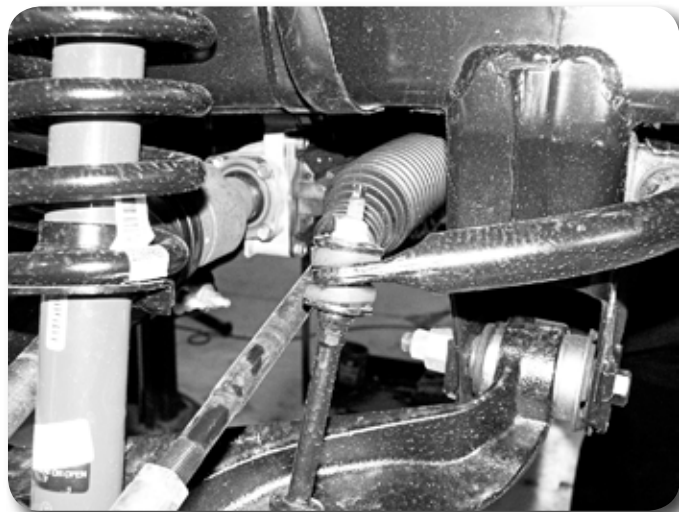

Figure 1

5. Remove the upper ball joint nut and use appropriate puller to disconnect the ball joint from the steering knuckle. Do NOT strike the aluminum knuckle with a hammer! Remove upper control arm from vehicle.
6. Disconnect the tie rod end from the steering knuckle using appropriate puller. Again do NOT strike the aluminum knuckle with a hammer!

7. Disconnect the brake caliper bracket from steering knuckle, hang caliper out of the way, do not allow the caliper to hang from the brakeline. Remove the brake rotors for safety.
8. Disconnect the ABS wire connector at the inner fender well. Remove wire from retaining clips.
9. Remove the lower strut bolt and nut. Fig 2

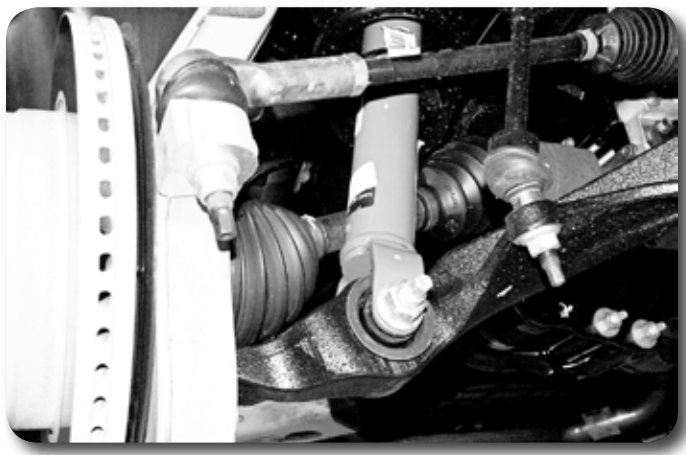

Figure 2

10. Remove upper strut nuts and remove strut assembly from vehicle.
11. Install the bushing preload plate on top of the strut assembly between the strut and spacer. Install on all vehicles even if the strut bushing does not protrude. Fig 3

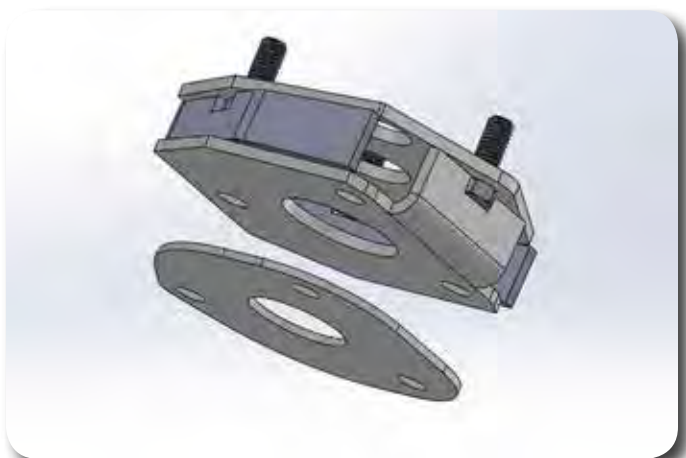

Figure 3

12. Install the new top spacer with factory nuts onto the strut assembly, the strut assembly can only be installed one way. It may be necessary to use a chrome socket for clearance in the access holes. Tighten to 40 ft-lbs. Fig 4

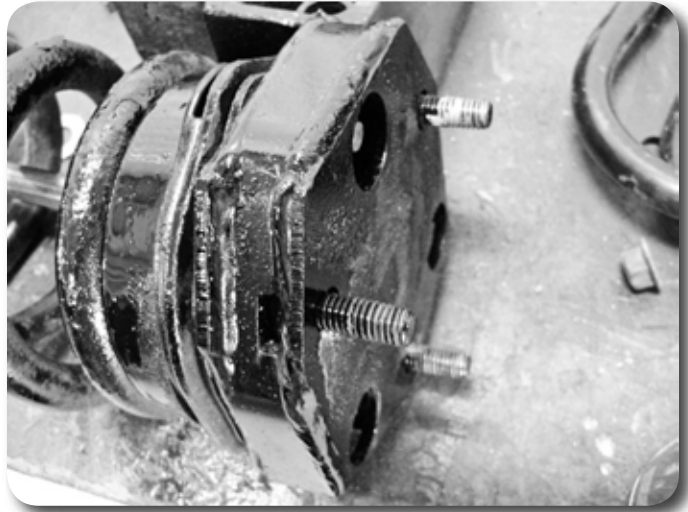

Figure 4

13. Attach the strut assembly to the frame with new 3/8" nuts with washers. Leave hardware slightly loose.
14. Swing the lower control arm up. Attach the lower control arm to the strut with factory hardware, do not tighten at this time.
15. Remove the stock upper control arms, retain all hardware.
16. Install new upper control arms with factory hardware. The arms will offset the ball joint to the rear of the vehicle. Leave loose at this time.
17. Attach steering knuckle to new upper control arm with new crown nut and cotter pin. Tighten to 65 ft-lbs, do not loosen to get cotter pin to align.
18. Grease the upper control arm assembly once installed. Fig. 5

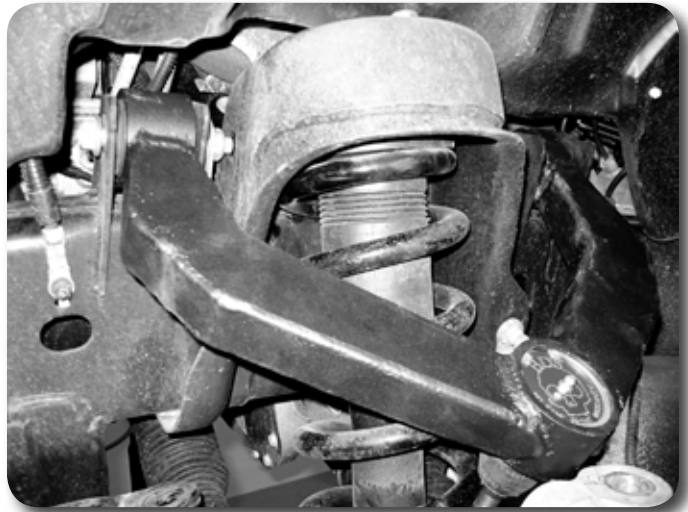

Figure 5

19. Reinstall brake rotors and calipers with factory hardware. Tighten to 130 ft-lbs
20. Attach tie rod to steering knuckle, tighten to 45 ft-lbs then an additional 90 degrees
21. Reconnect the ABS wire, secure with included zip ties.
22. Tighten upper strut hardware to 40 ft-lbs.

23. Install spacer sleeve on sway bar link, reassemble with factory bushings, cup washers, and nut. Use loctite on the nut. Do NOT over tighten the nut, tighten until the bushings begin to swell. It may be necessary to compress the suspension slightly to get the bushings at an appropriate angle to allow for assembly. The nylock portion should be just engaged into the threads. Fig 6a, 6b



Figure 6a



Figure 6b

24. Reinstall wheels, tighten to factory specifications
25. Lower vehicle to the ground. Tighten lower strut hardware to: 155 ft-lbs Upper control arm hardware to: 130 ft-lbs
26. Recheck all hardware for proper torque, check again after 500 miles and at regularly scheduled maintenance intervals.
27. A front end alignment must be performed.

### Post-Installation Warnings

1. Check all fasteners for proper torque. Check to ensure for adequate clearance between all rotating, mobile, fixed, and heated members. Verify clearance between exhaust and brake lines, fuel lines, fuel tank, floor boards and wiring harness. Check steering gear for clearance. Test and inspect brake system.
2. Perform steering sweep to ensure front brake hoses have adequate slack and do not contact any rotating, mobile or heated members. Inspect rear brake hoses at full extension for adequate slack. Failure to perform hose check/ replacement may result in component failure.
3. Perform head light check and adjustment.
4. Re-torque all fasteners after 500 miles. Always inspect fasteners and components during routine servicing.